

Series

S1

... with single chamber

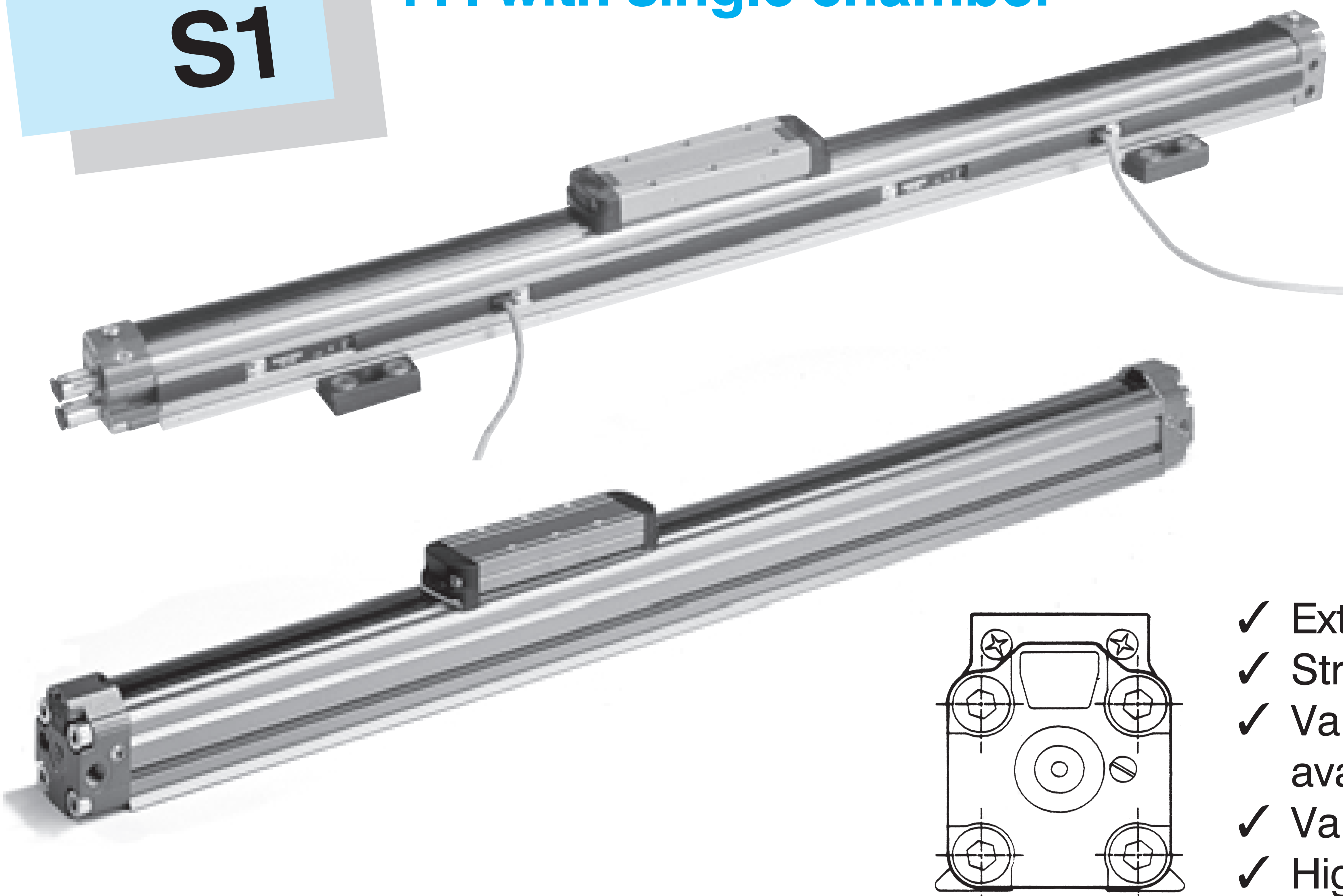

- ✓ Extruded profile in aluminium Ø 16 ÷ 50 mm.
- ✓ Stroke to 5 m.
- ✓ Various supply port configurations available.
- ✓ Various carriage types.
- ✓ High translation speed 1 ÷ 3 m/s.

Series

S5

... with integrated guides

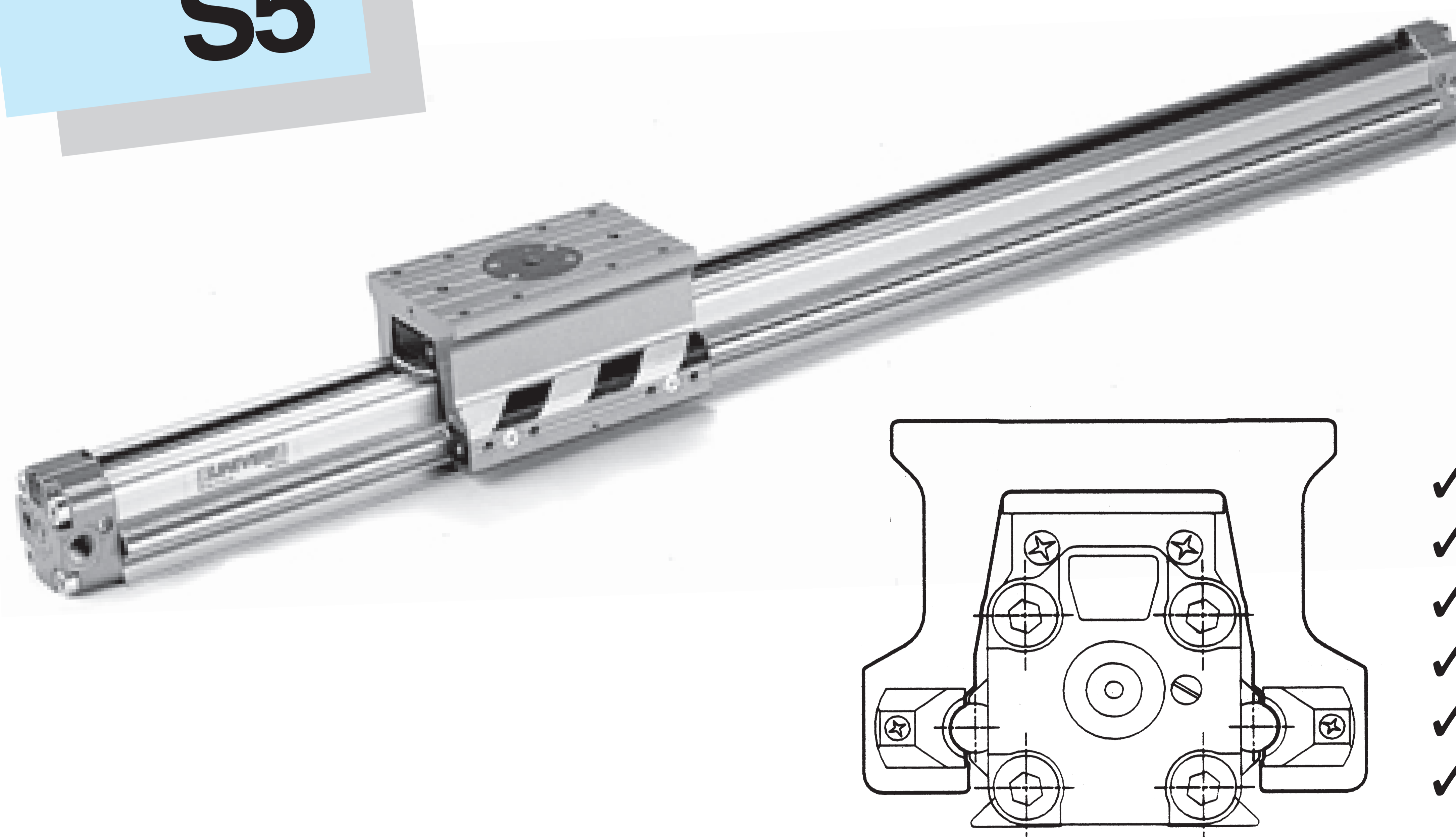

- ✓ Extruded profile in aluminium Ø 25 ÷ 50 mm.
- ✓ Stroke to 6 m.
- ✓ Flexible bearing system.
- ✓ Plastic bearings reduce noise.
- ✓ Translation speed 0,2 ÷ 1,5 m/s.
- ✓ Available with locking unit.

Series

VL1

... with integrated guides 90°

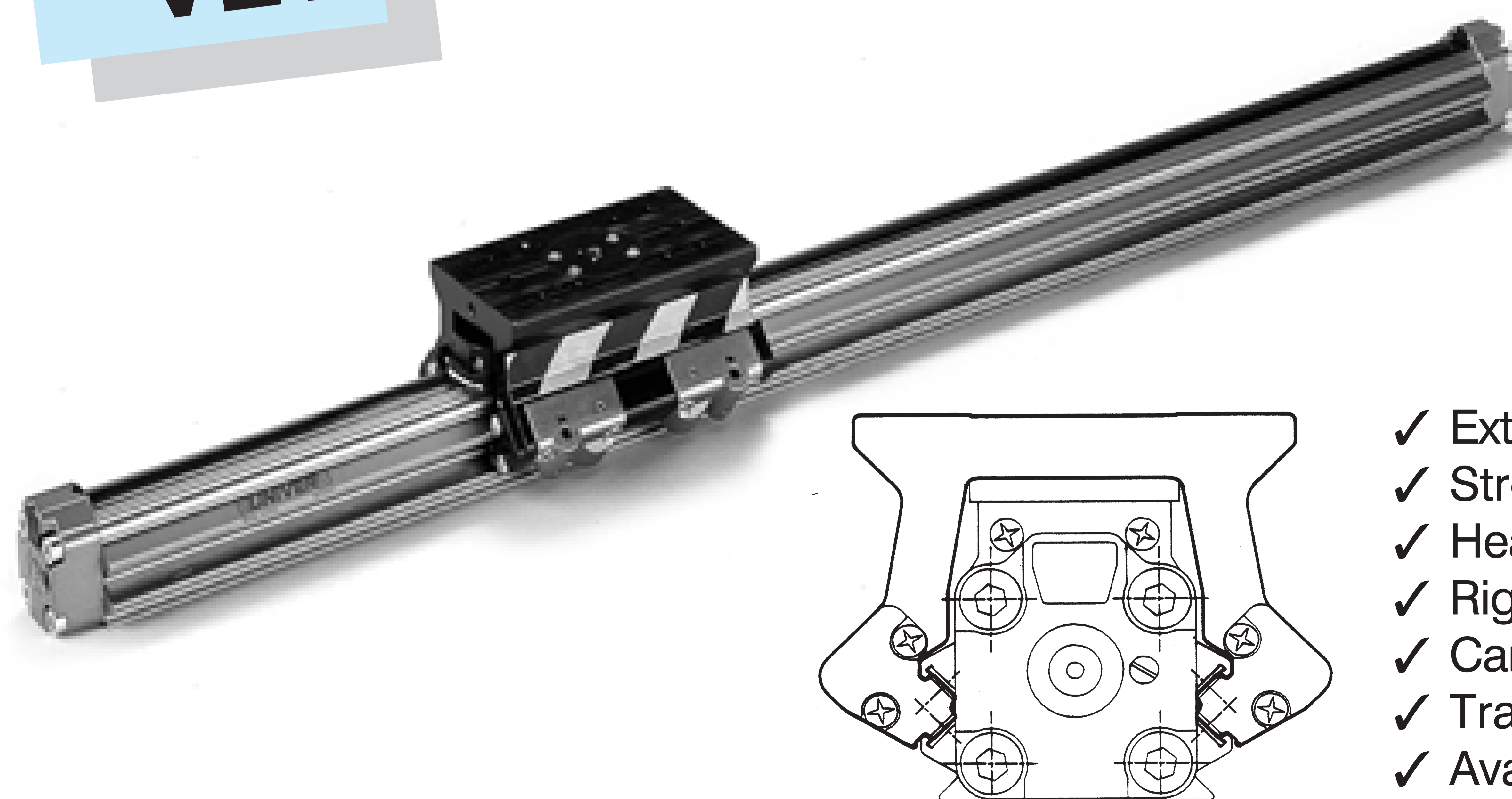

- ✓ Extruded profile in aluminium Ø 25 ÷ 50 mm.
- ✓ Stroke to 6 m.
- ✓ Heavy duty precision series.
- ✓ Rigid ball bearing system.
- ✓ Carriage slide on ball bearings.
- ✓ Translation speed 0,2 ÷ 2 m/s.
- ✓ Available with locking unit.

High-Tech

TECHNICAL CHARACTERISTICS

Working pressure: 3-10 bar
 Ambient temperature: -20°C ÷ +80°C
 Fluid: filtered air, **with or without lubrication**
 up to 500 mm
 Bore size: Ø 16-25-32-40-50 mm
 Standard strokes: up to 5 meters (Ø 16 mm)
 up to 6 meters (Ø 25 ÷ 50 mm)
 Min. speed required for regular translation: 7 ÷ 20 mm/s.
 Translation speed: 3 m/s max.
 Carriage types: standard, medium, long, double medium
 Integrated guides: S5 series: round steel shafts
 VL1 series: steel foils at 90°
 External carriage slide: S5 series: with plastic
 sliding shoes
 VL1 series: with ball bearings

Upon request

- Magnetic version for S1 series (except for Ø 16 magnetic version standard); for S5 series a special magnetic sensor holder extrusion DKS series is foreseen (section accessories page 6-V).
- Magnetic sensor DH-series - DF-series (Ø 16) (section accessories page 2-V).
- Slide units with standard or long carriage for S1 series (J30 - J31 series) page 47.
- Locking unit for S5 - VL1 series (L6 series) page 7.

High-Tech

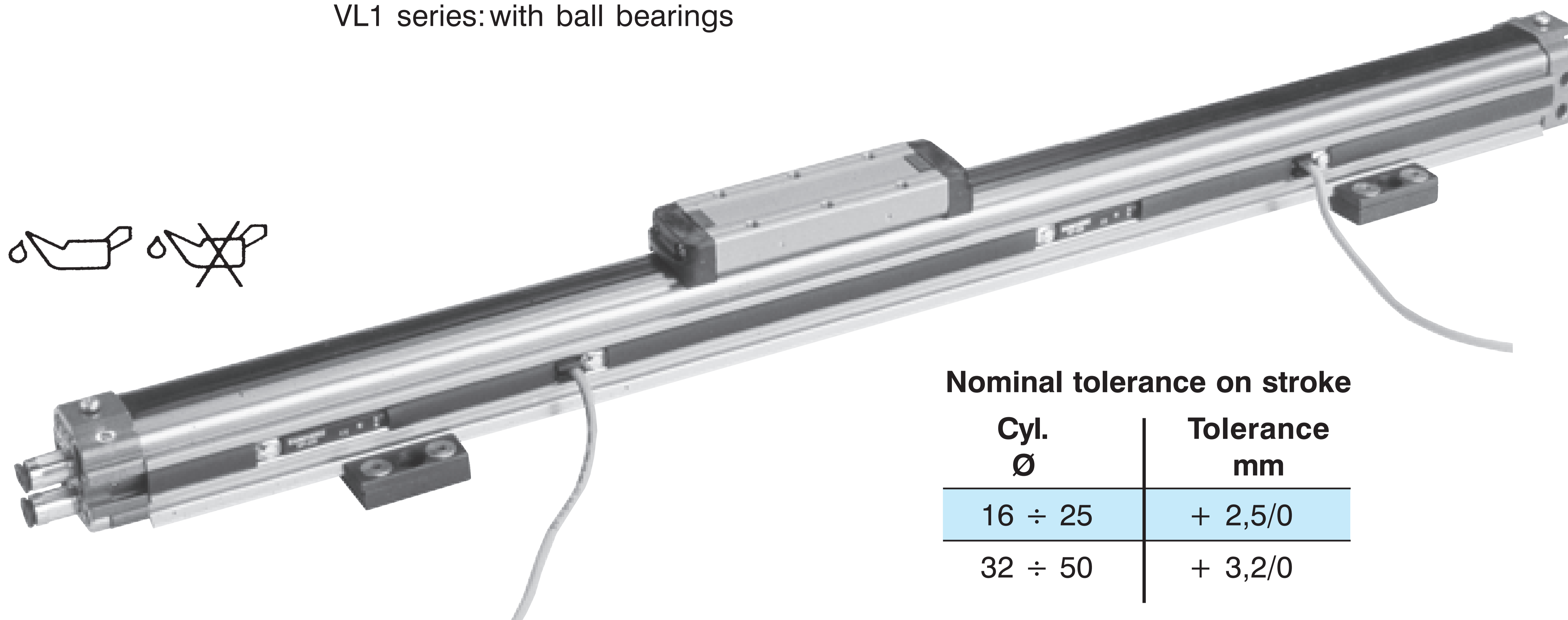

Nominal tolerance on stroke

Cyl. Ø	Tolerance mm
16 ÷ 25	+ 2,5/0
32 ÷ 50	+ 3,2/0

End-caps in die-cast light alloy with various supply port options (see picture below). The unique method of stripseal attachment permits easy assembly and disassembly, without needing tools or continuous adjustment.

Slideway sealing. The pneumatic sealing is achieved through an elastomer stripseal reinforced with Kevlar. This system guarantees dimensional stability even with high translation speeds. The external protection seal consists of a thermoplastic stripseal reinforced with Kevlar.

Ø 16 mm

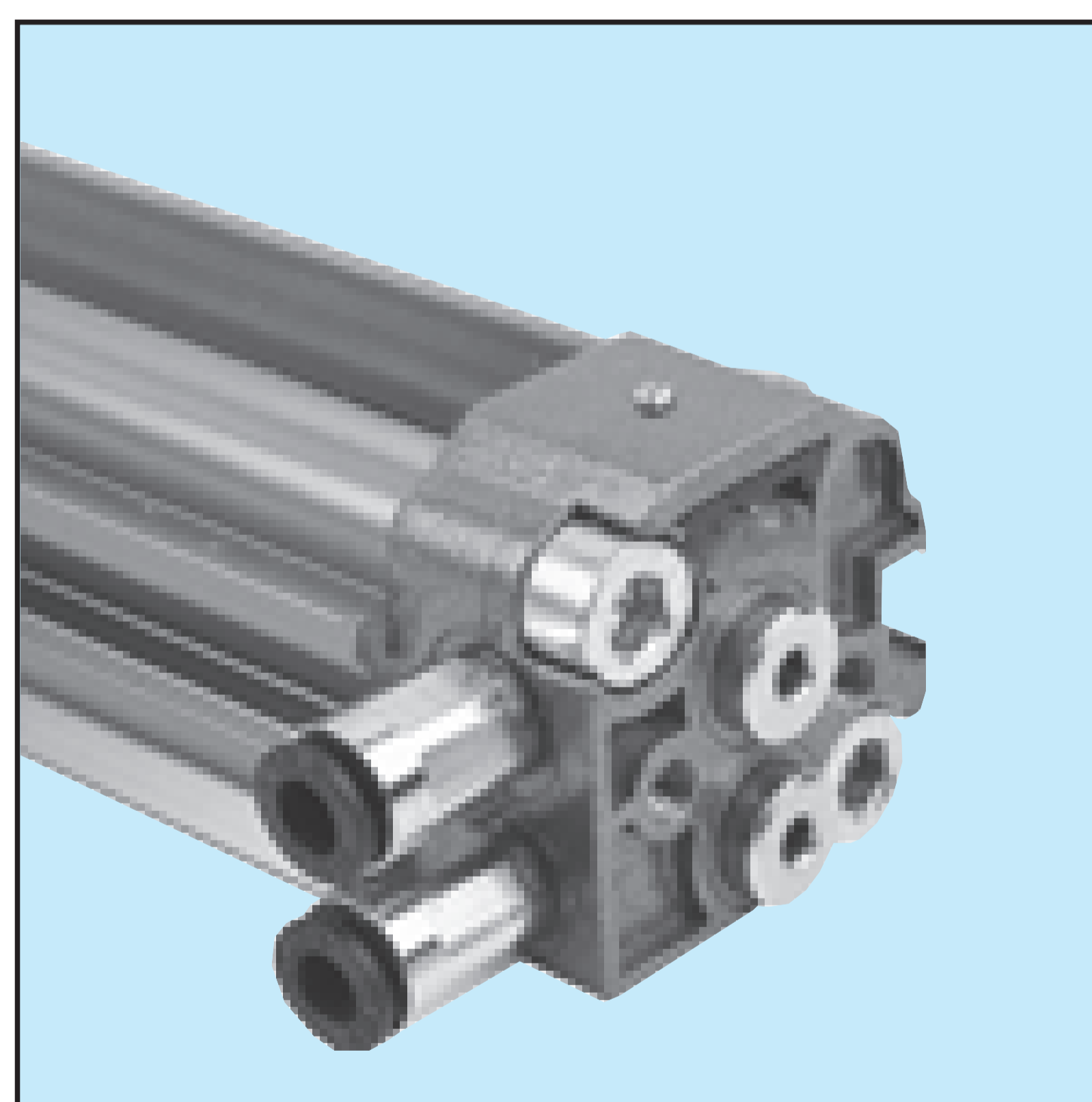

Double side supply

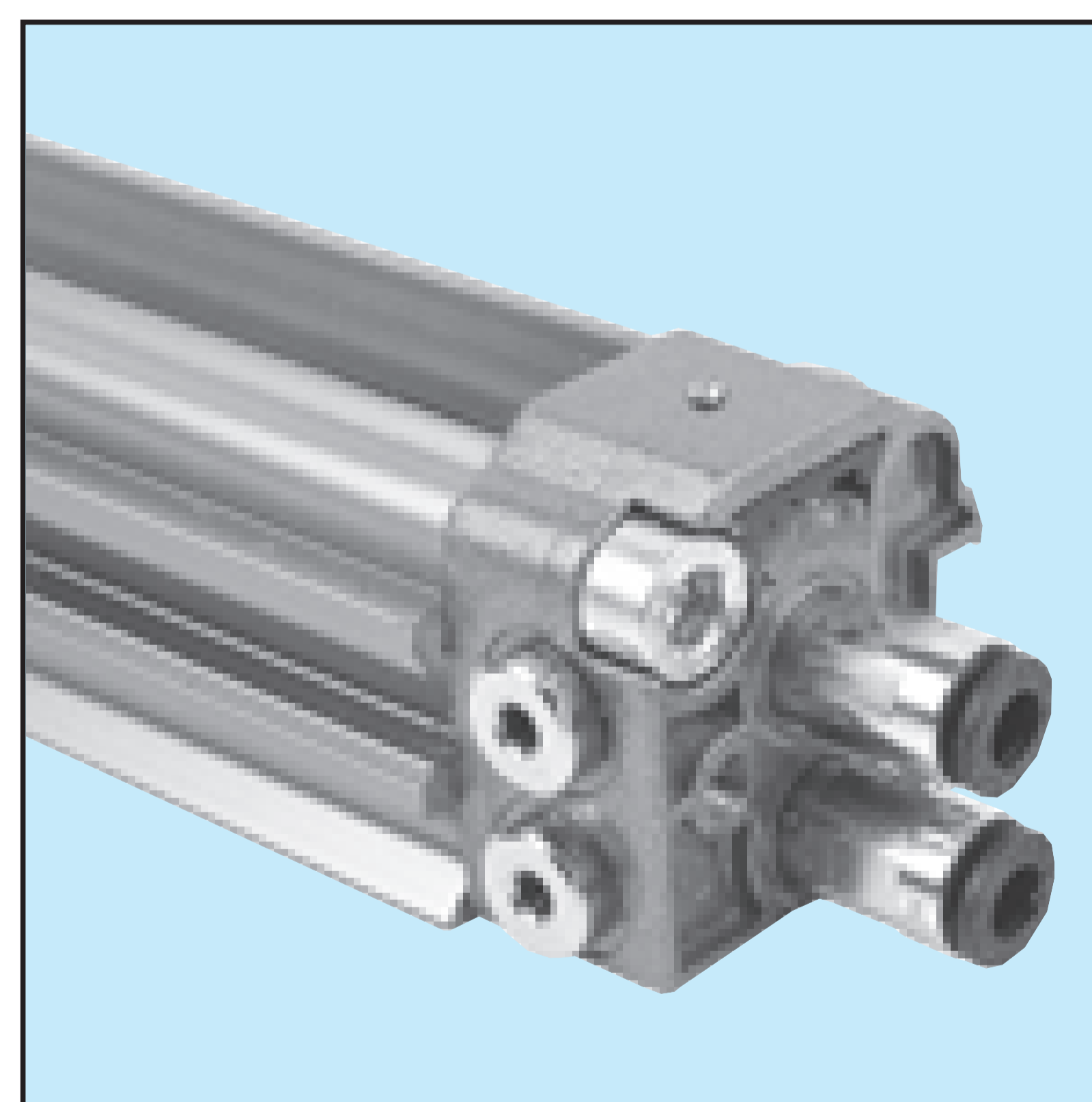

Double rear supply

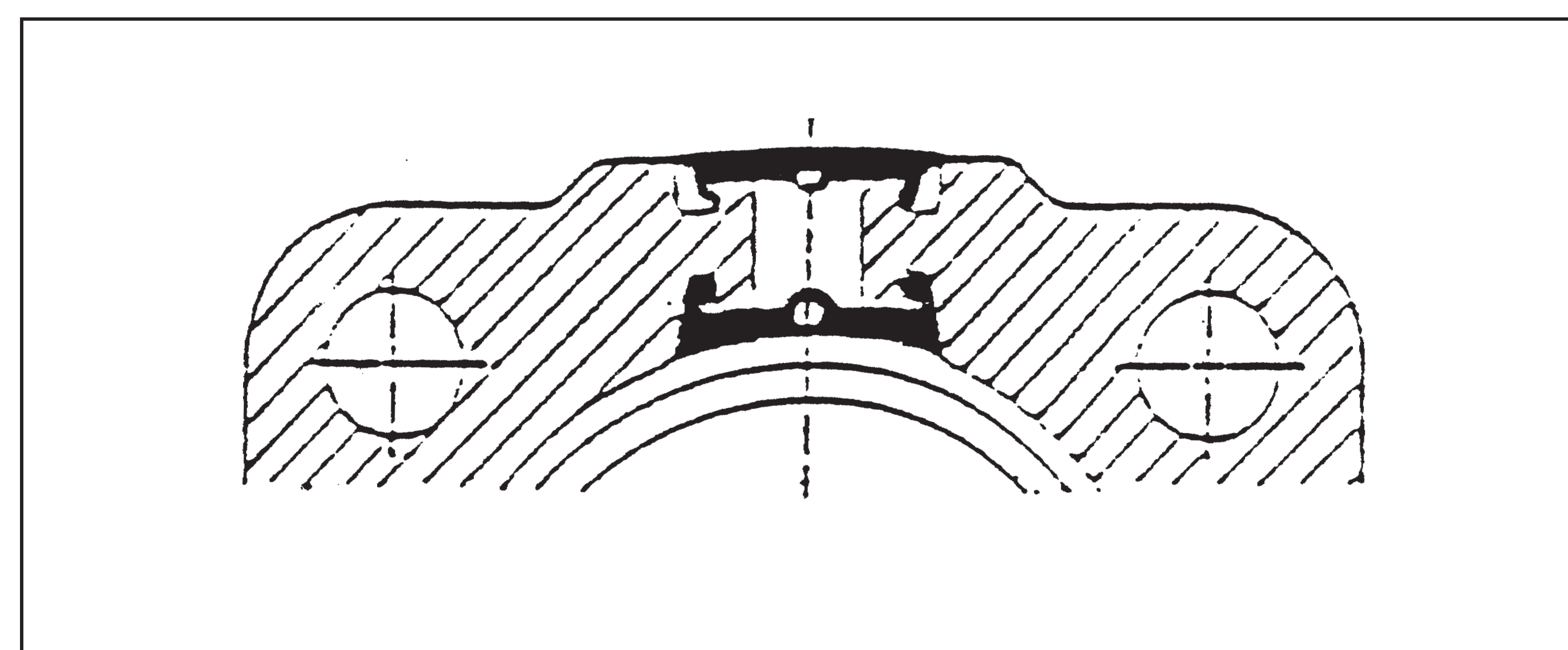

Ø 25 ÷ 50 mm

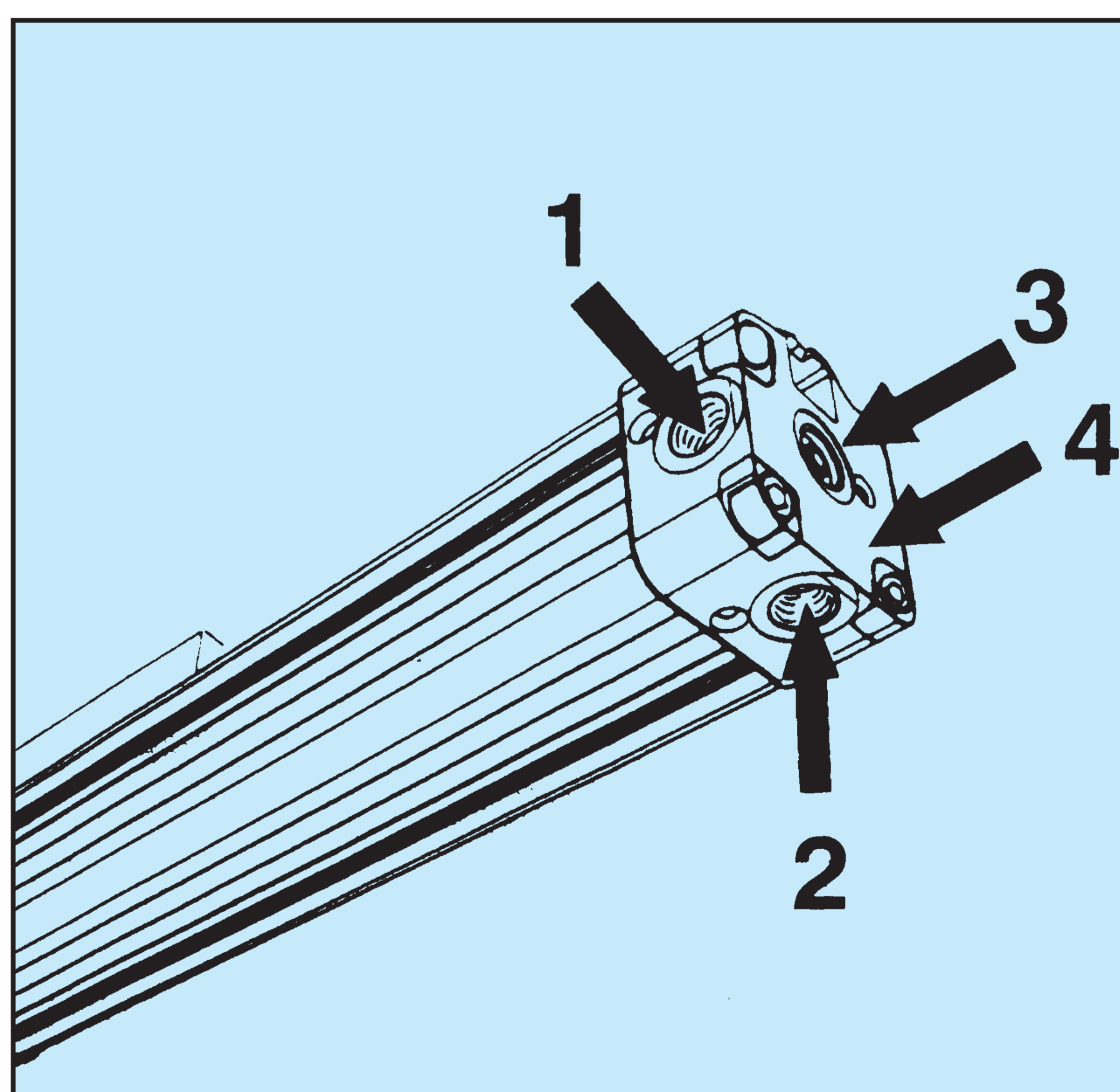

- 0 = no supply port (left end-cap only, when both chambers are supplied from the right end-cap)
- 1 = side
- 2 = dorsal
- 3 = rear
- 4 = both chambers supplied from one end-cap

Piston - Carriage assembly in extruded aluminium alloy with thermoplastic guide bearings. The piston is fitted with double lip seals which automatically self-compensate against wear; upon request it is possible to fit it with permanent magnets (S1 series).

Cylinder barrel in extruded aluminium alloy with internal and external anodisation.

Pneumatic adjustable cushions with two regulation screws in each end-cap allow an improved regulation of piston deceleration.

Mechanical rubber shock absorbers avoid mechanical stress and reduce machinery noise (below 50 dB).

Examination and verification of the cushioning

In a system with moving masses, as in the case of rodless cylinders, it is essential to control the dissipation of the system's kinetic energy as it is brought to a stop.

It is necessary, first of all, to establish and verify the most suitable method of cushioning the system, in order to avoid the moving mass (carriage with load) striking against the end-caps and compromising the life of the cylinder.

If the point corresponding to a given load and speed lies **beneath** the appropriate curve, the cushioning is able to absorb the kinetic energy of the system.

Vice versa if the point lies **above** the curve, the cushioning **is not able to absorb the kinetic energy**, in which case you must:

- a) decrease the load and maintain the translation speed
- b) decrease the speed and maintain the load
- c) select a cylinder with a bigger bore.

The cushioning capacity is shown in the diagram below, referenced to the final speed as the carriage approaches the end-caps, for S1 - S5 - VL1 series.

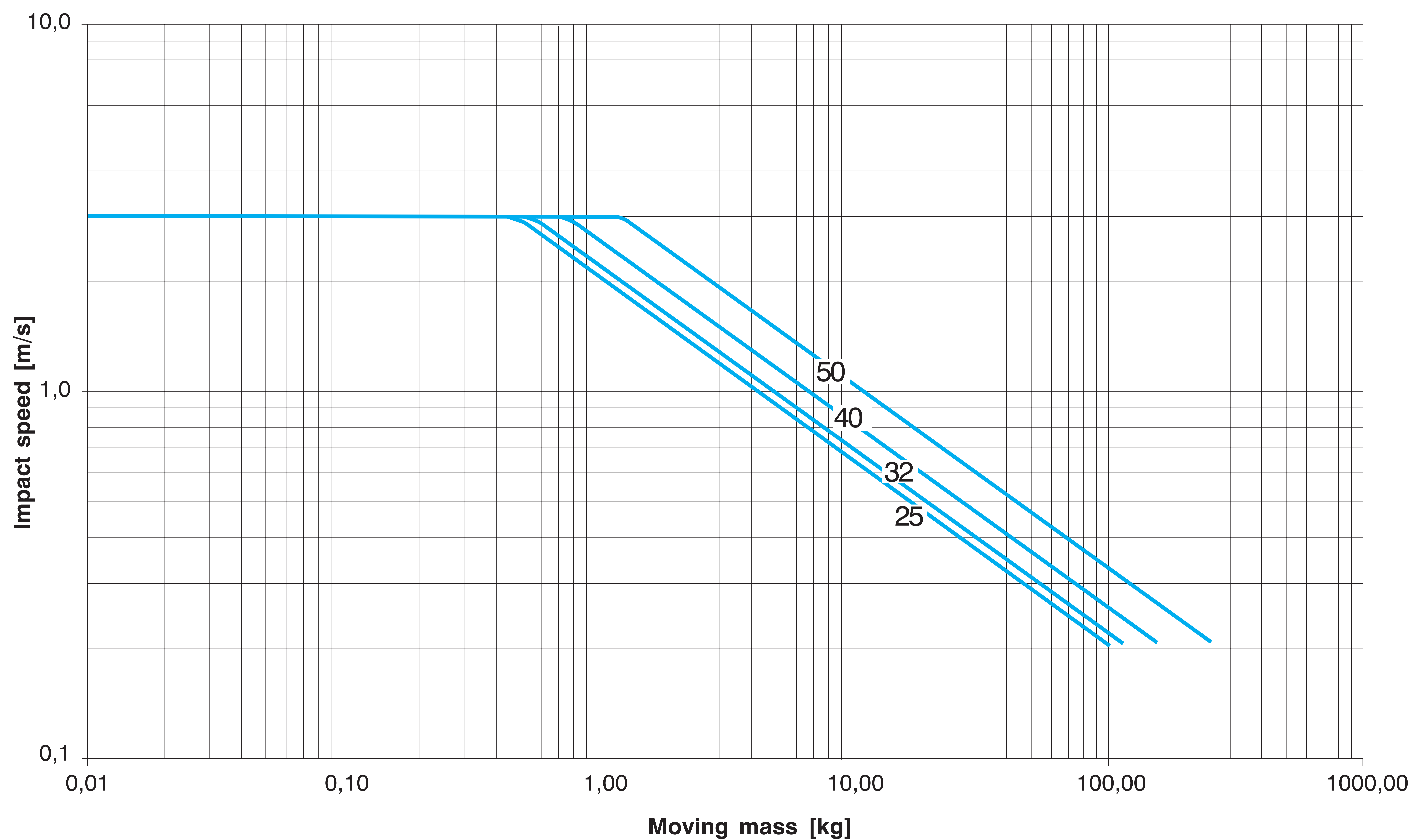

If it is not possible to absorb the kinetic energy with the cushioned end-caps and modify the parameters (a-b-c shown at page 11), an additional cushioning is necessary to reduce the load speed before the cylinder strikes the cushion.

The additional cushion can be:

- a **pneumatic cushion** with electronic control;
- a **hydraulic cushion**, available on the market.

The mass movement generates loads to the cylinder, connected both to the weight forces (load values are constant) and to the inertia forces which originate in the acceleration or deceleration phases of the piston at the beginning and at the end of the stroke.

A typical fatigue stress arises in which the load value affects the life of the structure. The following acceptable loads refer to a life expectancy of 20000 km.

The indicated values (in the corresponding pages of each series) represent the maximum values of the forces and of the torques which can be developed in acceleration phases. Thus, in order to evaluate if an application is correct, the generated inertia forces and the corresponding torque should be calculated.

To calculate the inertia forces, the length L of the deceleration distance must be known. If the pneumatic cushion of the cylinder head is used, the values are:

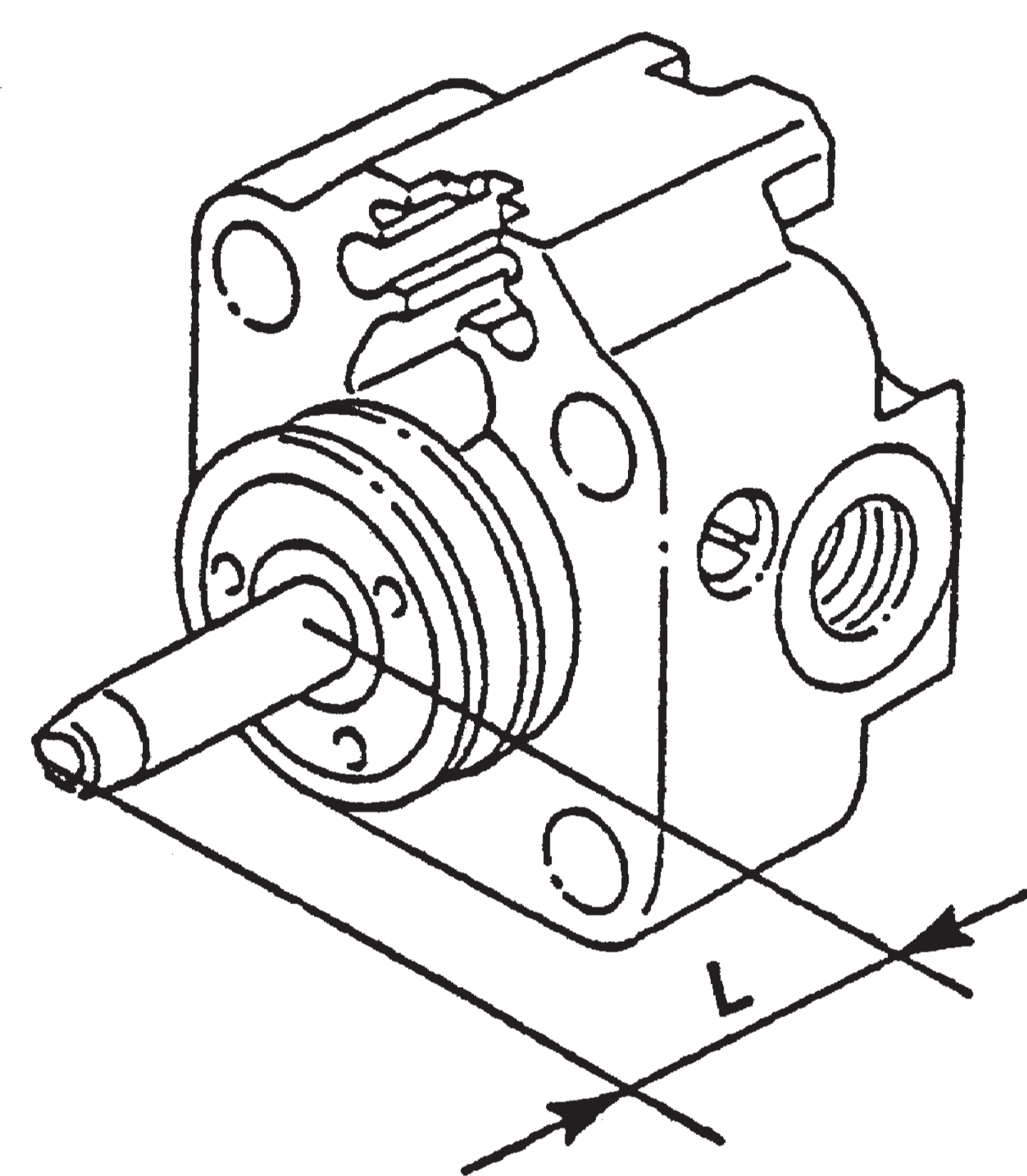

Ø (mm)	L (mm)
16	16,5
25	25,0
32	32,5
40	41,5
50	52,0

The usual formulas of mechanics are then applied. For instance, when moving a mass M (kg) at an impact speed V (m/s) with b1, b2 and b3 (mm) arms to the longitudinal axis of the piston, the inertia force F, in longitudinal direction and the corresponding torques are calculated as follows:

$$F (N) = M \cdot a = M \cdot \frac{V^2}{2 \cdot (L \cdot 10^{-3})}$$

$$M_1 (Nm) = F \cdot (b_1 \cdot 10^{-3})$$

$$M_2 (Nm) = M \cdot g \cdot (b_2 \cdot 10^{-3})$$

$$M_3 (Nm) = F \cdot (b_3 \cdot 10^{-3})$$

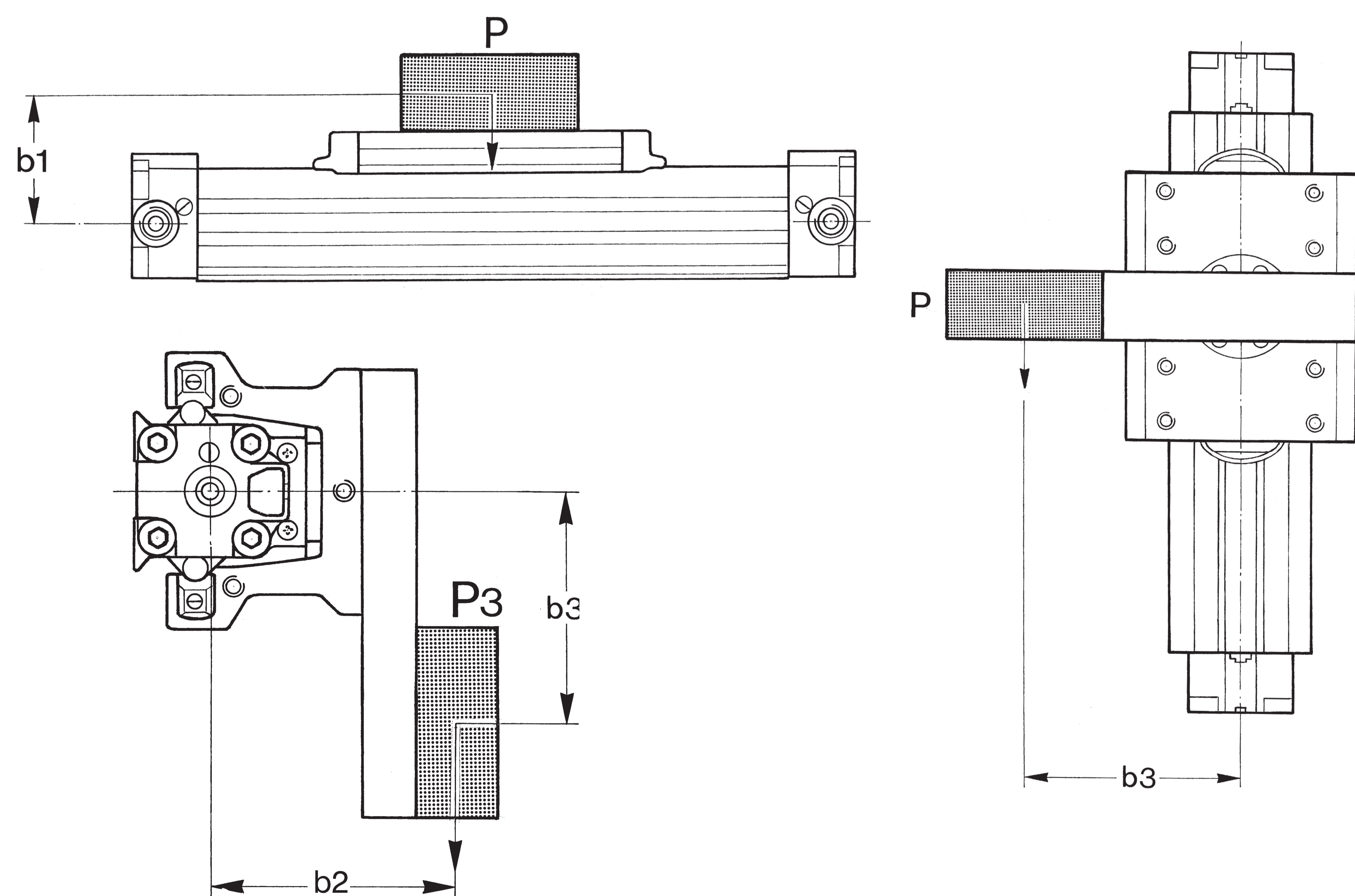

While F, M1 and M3 can have both static and inertia components, M2 is a static component only.

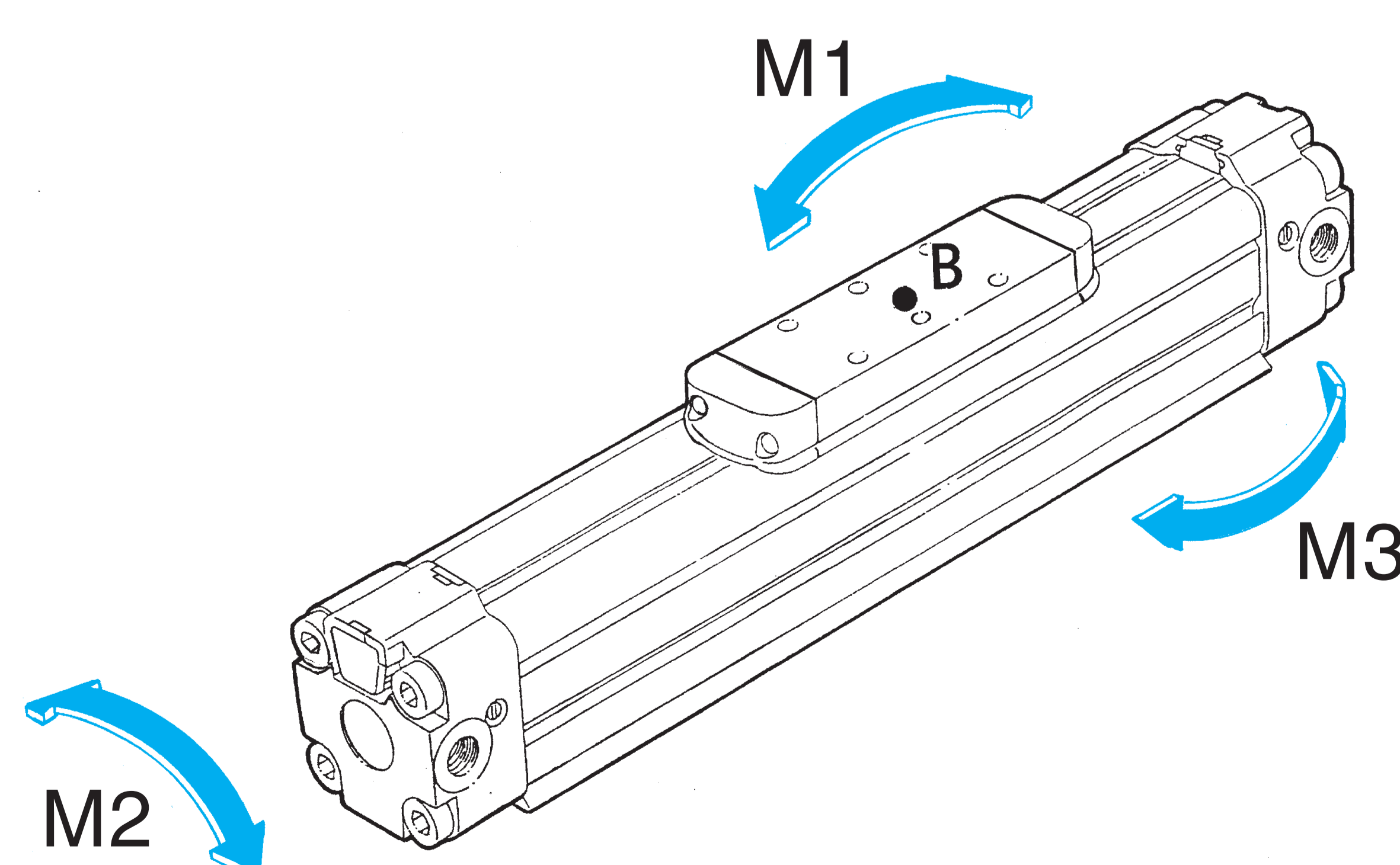

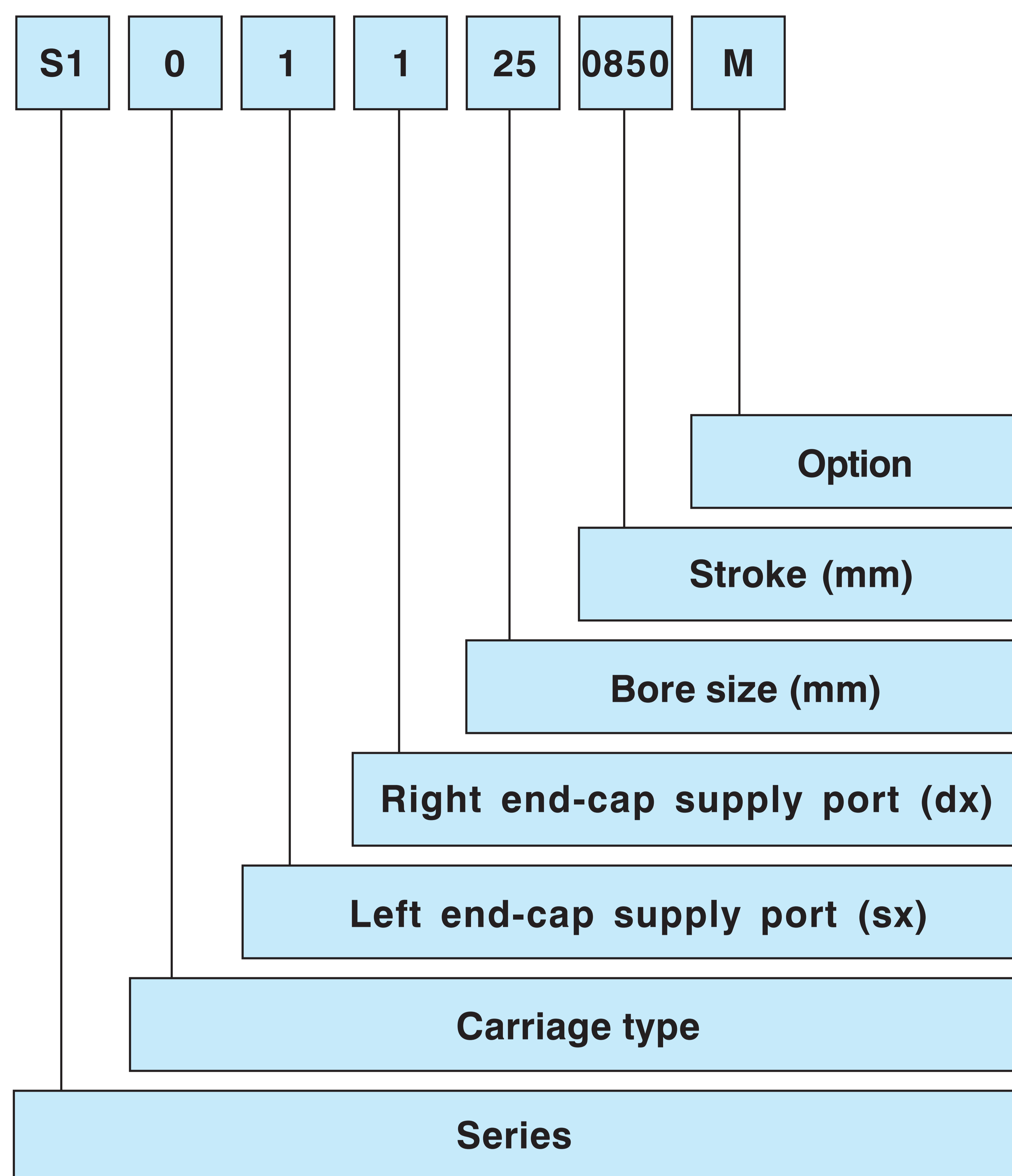

CARRIAGE TYPE

- 0 = Standard carriage
(for S5 series except Ø 40 and 50 mm)
- 2 = Medium carriage *
- 3 = Long carriage *

LEFT END-CAP SUPPLY PORT

- 0 = No supply port (when both chambers are supplied from the right end-cap)
- 1 = Side supply port *
- 2 = Bottom supply port *
- 3 = Rear supply port *

RIGHT END-CAP SUPPLY PORT

- 1 = Side supply port (twin Ø 16 mm)
- 2 = Bottom supply port *
- 3 = Rear supply port (twin Ø 16 mm)
- 4 = Both chambers supplied from the right end-cap

BORE SIZE

16 - 25 - 32 - 40 - 50

STROKE

Up to 5000 mm Ø 16 mm
Up to 6000 mm Ø 25 ÷ 50 mm

OPTION

M = Magnetic version standard for Ø 16 mm, upon request for Ø 25 ÷ 50 mm (for version S1 only).
For S5 Series, the magnetic option is obtained by means of a magnetic switch mounting rail (DKS Series) which is to be ordered separately (Section accessories page 6).

* = Except Ø 16 mm

SERIES

- S1** = Single chamber
- S5** = Integrated guides/plastic bearings

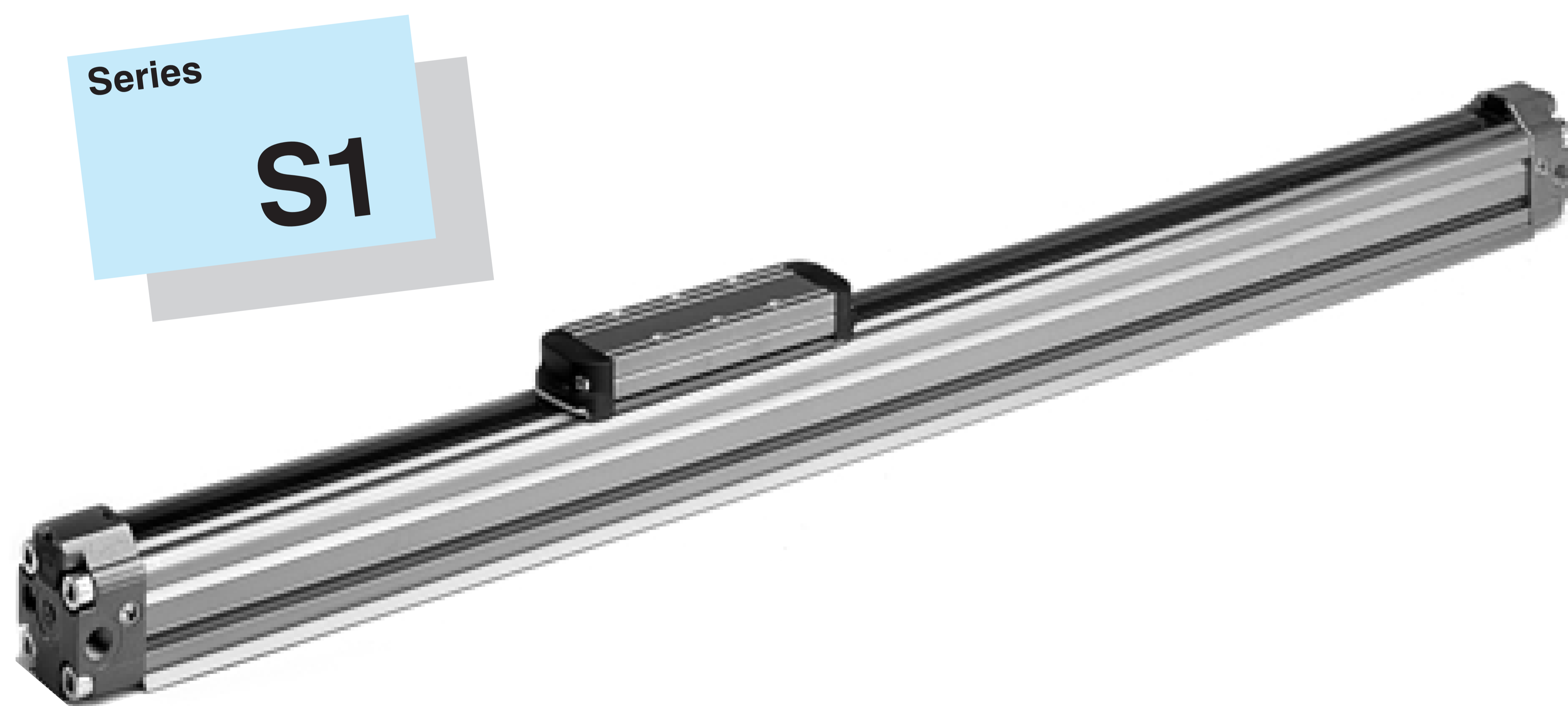

High-Tech

Rodless cylinders with standard carriage - 6 fixing holes

Ø 16 mm

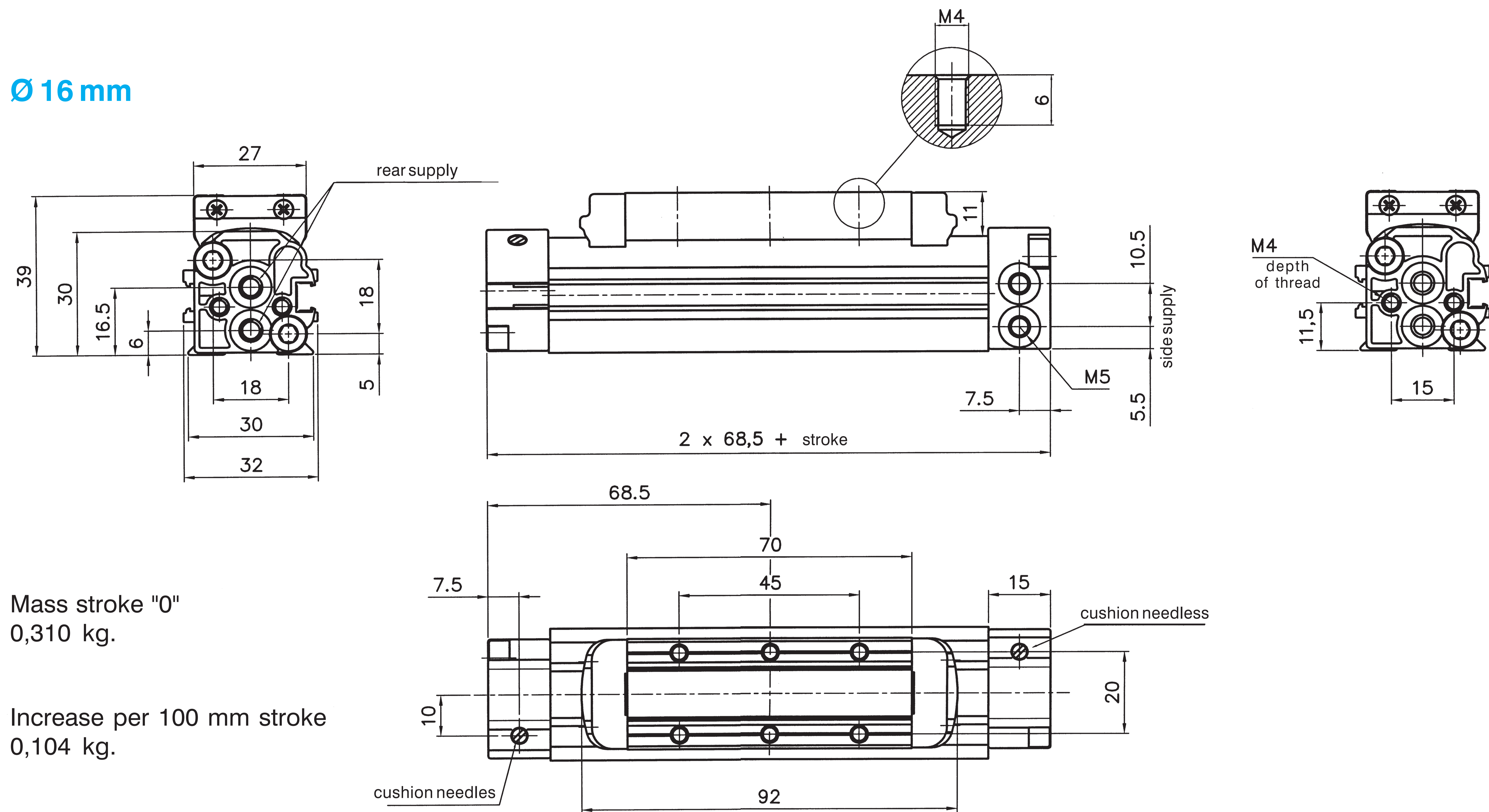

Mass stroke "0"
0,310 kg.

Increase per 100 mm stroke
0,104 kg.

Ø 25 ÷ 50 mm

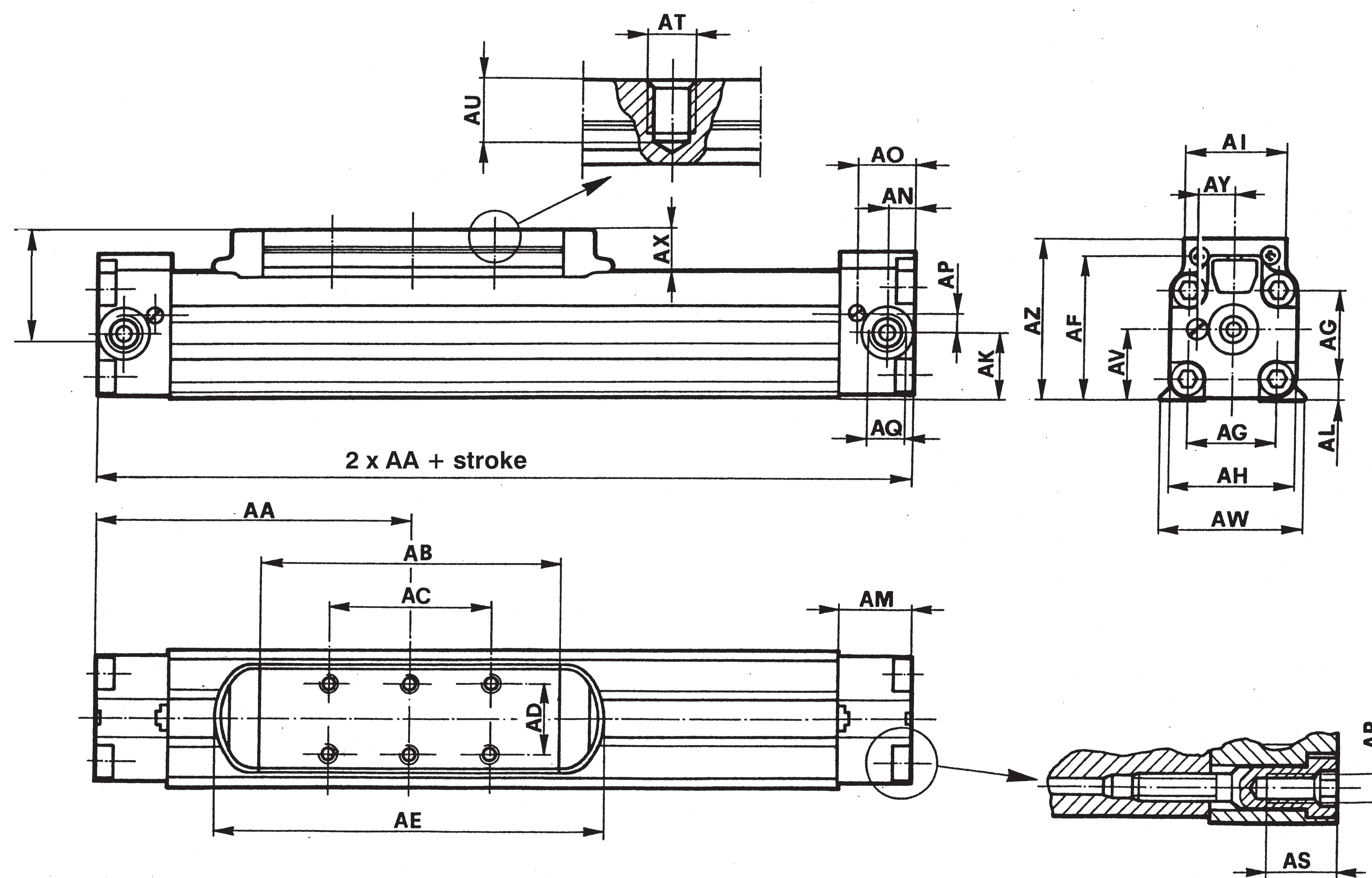

Cyl Ø	AA	AB	AC	AD	AE	AF	AG	AH	AI	AK	AL	AM	AN	AO	AP	AQ	AR	AS	AT
25	100	95	50	24	130	48,3	28	40,5	33	20,2	7	24	7,4	18,2	5,7	G1/8	M5	12	M5
32	125	118	65	31	156	57	35	50	40	25,3	8	29	10,3	22,5	7,3	G1/4	M6	15,5	M6
40	150	134	65	31	177	74	44	64	44	33,8	11,8	33	12,5	26,5	8,7	G3/8	M8	20	M6
50	175	164	105	39	211	90,7	55	80	54	41,4	14,7	33	14,2	25,7	11,8	G3/8	M10	20	M8
Cyl Ø	AU	AV	AW	AX	AY	AZ	Mass (kg) at "0" stroke				Weight increase (kg) per additional 100mm stroke								
25	9	22,8	42,8	16	12,2	57,6	0,750				0,210								
32	9	28	54,5	16	14,2	66,2	1,310				0,325								
40	11	37	67	19,5	16,5	85,8	2,600				0,555								
50	12	47,7	86	20,5	19,1	103	4,785				0,955								

Values of the static load; please note that under dynamic conditions the load must be reduced due to the effects associated with the speed. The torque is the product of load (Newton) per arm (meters), i.e. the distance between the center of gravity of the load and the longitudinal axis of the piston (technical characteristics see page 11-12-II).

Cyl. Ø	Standard carriage				Medium carriage			Long carriage					
	F (N)	P1 (N)	P2 (N)	P3 (N)	M1 (Nm)	M2 (Nm) ♦	M3 (Nm)	M1 (Nm)	M2 (Nm)	M3 (Nm)	M1 (Nm)	M2 (Nm)	M3 (Nm)
16	125	100	100	25	5	0,2	0,8	-	-	-	-	-	-
25	250	200	200	50	8	2	3	14	3	5	25	6	9
32	420	250	250	65	9	3	4	15	4	7	28	8	12
40	640	350	350	90	11	9	14	16	14	20	31	27	39
50	1050	500	500	125	19	13	19	29	20	30	52	36	53

♦ It is not advisable to use the cylinder in applications with high stress.

Medium carriage - 6 fixing holes for cylinders Ø 25 ÷ 50 mm

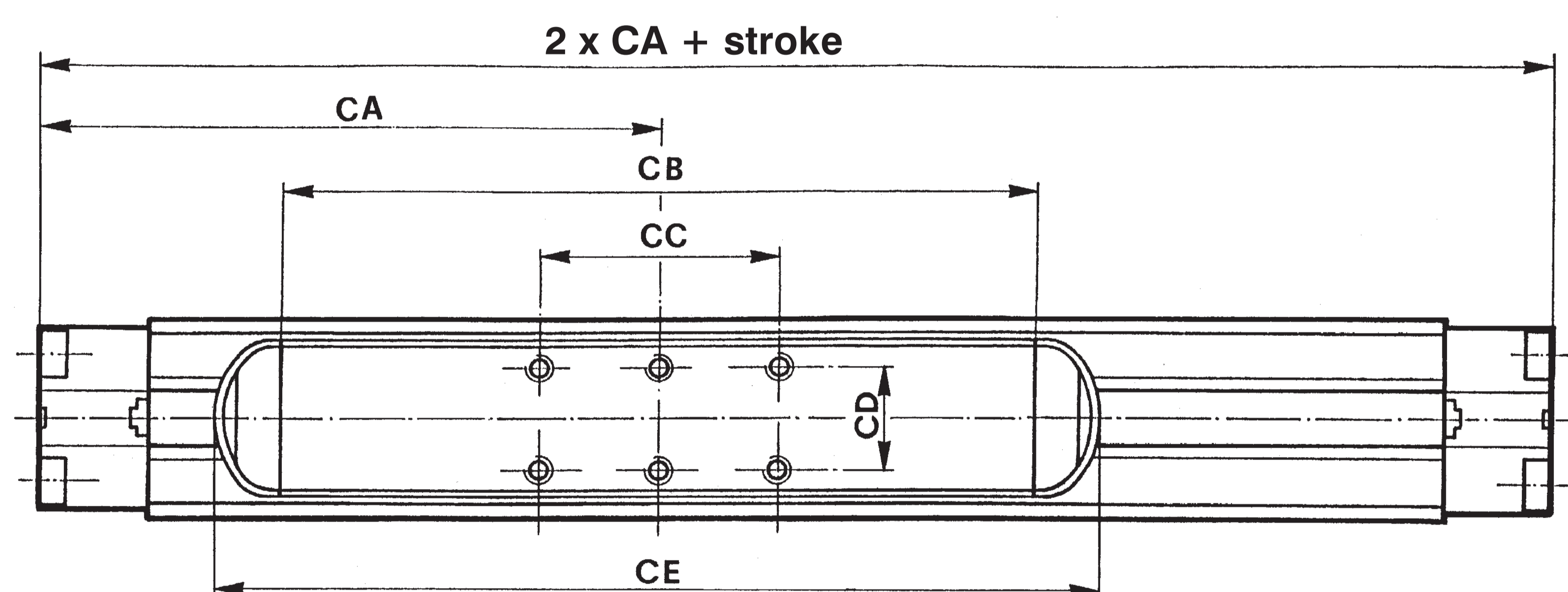

Cyl. Ø	CA	CB	CC	CD	CE	Mass (kg) at "0" stroke
25	114,5	125	50	24	160	0,84
32	142,5	153	65	31	191	1,48
40	169	172	65	31	215	2,91
50	205	224	105	39	271	5,55

Long carriage - 10 fixing holes for cylinders Ø 25 ÷ 50 mm

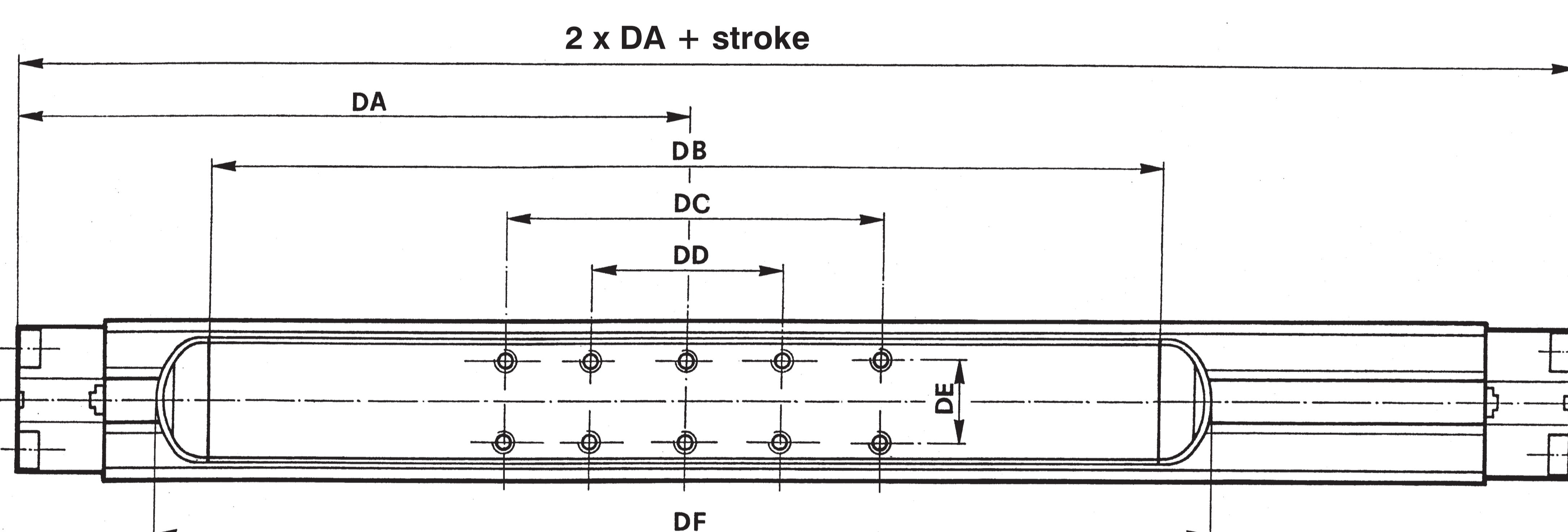

Cyl.Ø	DA	DB	DC	DD	DE	DF	Mass (kg) at "0" stroke
25	147,5	190	100	50	24	225	1,05
32	190	248	130	65	31	286	1,93
40	225	284	130	65	31	327	3,80
50	277	364	315	105	39	411	7,33

N.B. in cases where the rodless cylinder is mounted on external rigid guides, **it is necessary** to fit the oscillating mounting bracket onto the carriage (SF- 24 . . . series, see page 23-II), in order to isolate the cylinder from the rigid structure.
Other accessories from page 22-II.

High-Tech

Rodless cylinders with integrated guides and standard carriage - 8 fixing holes

High-Tech

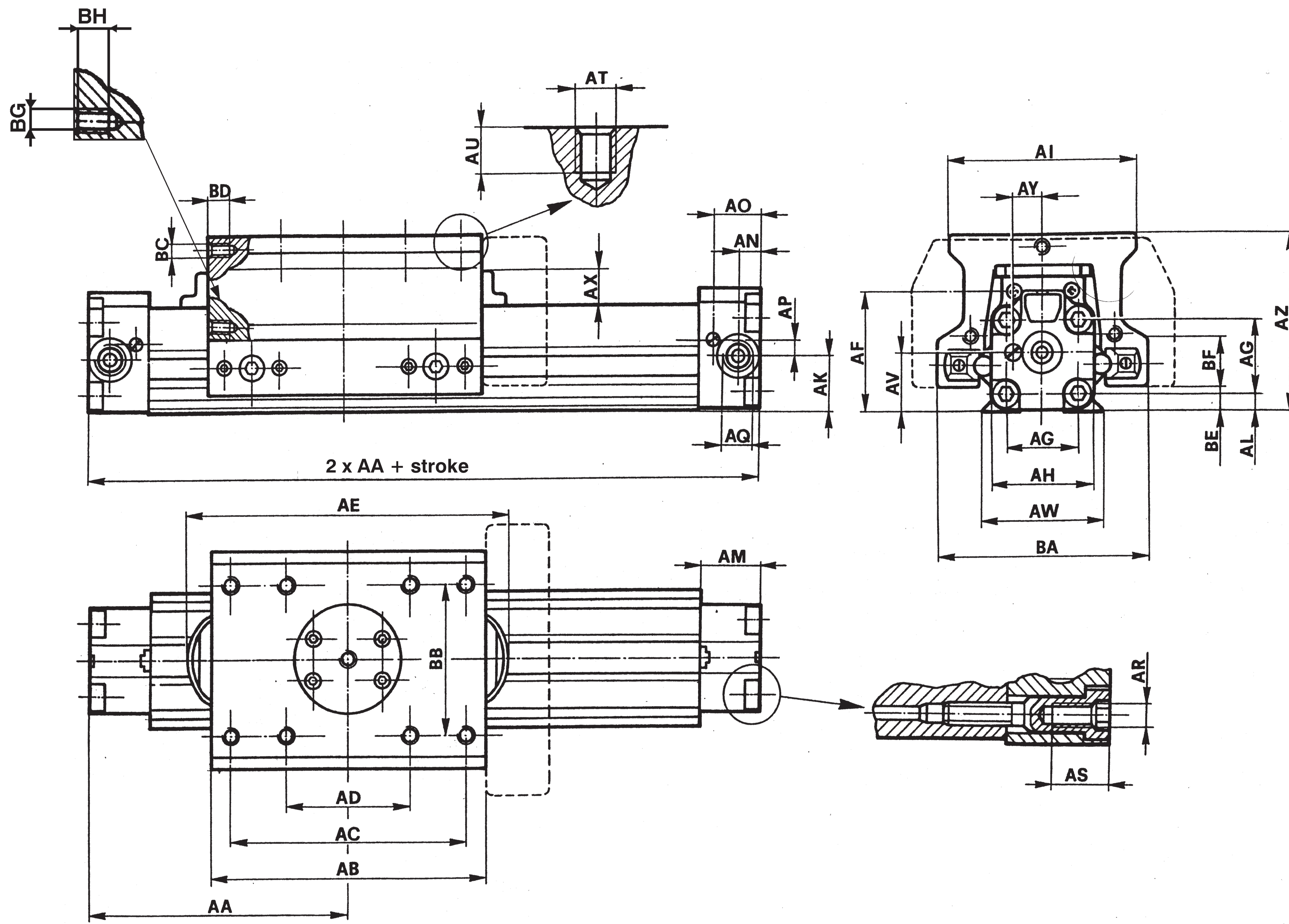

Cyl. Ø	AA	AB	AC	AD	AE	AF	AG	AH	AI	AK	AL	AM	AN	AO	AP	AQ	AR	AS	AT
25	100	106	90	50	130	48,3	28	40,5	70	20,2	7	24	7,4	18,2	5,7	G 1/8	M5	12	M6
32	125	140	115	55	156	57,0	35	50	88	25,3	8	29	10,3	22,5	7,3	G 1/4	M6	15,5	M8
40							44	64	90	33,8	11,8	33	12,5	26,5	8,7	G 3/8	M8	20	M8
50							55	80	100	41,4	14,7	33	14,2	25,7	11,8	G 3/8	M10	20	M8

Cyl. Ø	AU	AV	AW	AX	AY	AZ	BA	BB	BC	BD	BE	BF	BG	BH	Mass (kg) at "0" stroke	Weight increase (kg) per additional 100 mm stroke
25	10	22,8	42,8	16	12,2	71,8	85	50	M6	15	5,7	24	M6	15	1,625	0,365
32	12	28	57	16	14,2	82,5	100	67,5	M6	15	7	24,5	M6	15	2,775	0,495
40	14	37	67	19,5	16,5	106,6	135	65	M6	15	7	39	M6	15		0,92
50	16	47,7	86	20,5	19,1	123,7	149	76,5	M8	16	7,2	41	M6	15		1,28

The dotted line indicates the overall dimensions of the locking unit; fixing holes of the locking unit see page 8-II.

Values of the static load; please note that under dynamic conditions the load must be reduced due to the effects associated with the speed. The torque is the product of load (Newton) per arm (meters), i.e. the distance between the center of gravity of the load and the longitudinal axis of the piston.

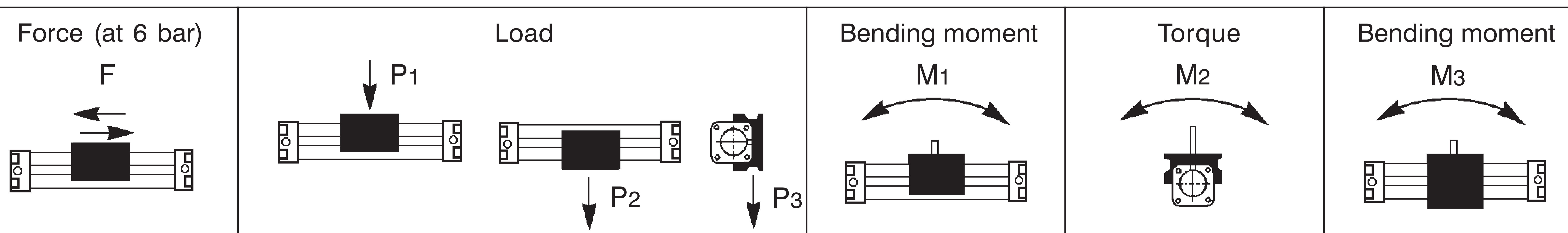

Cyl. Ø	Standard carriage			Medium carriage			Long carriage						
	F (N)	P1 (N)	P2 (N)	P3 (N)	M1 (Nm)	M2 (Nm)	M3 (Nm)	M1 (Nm)	M2 (Nm)	M3 (Nm)			
25	250		400		13	8	16	20	10	25	40	15	50
32	420		400		20	9	27	30	12	40	55	18	75
40	640		600		not foreseen			60	30	80	110	45	150
50	1050		800		not foreseen			85	50	110	150	75	210

Medium carriage - 8 fixing holes

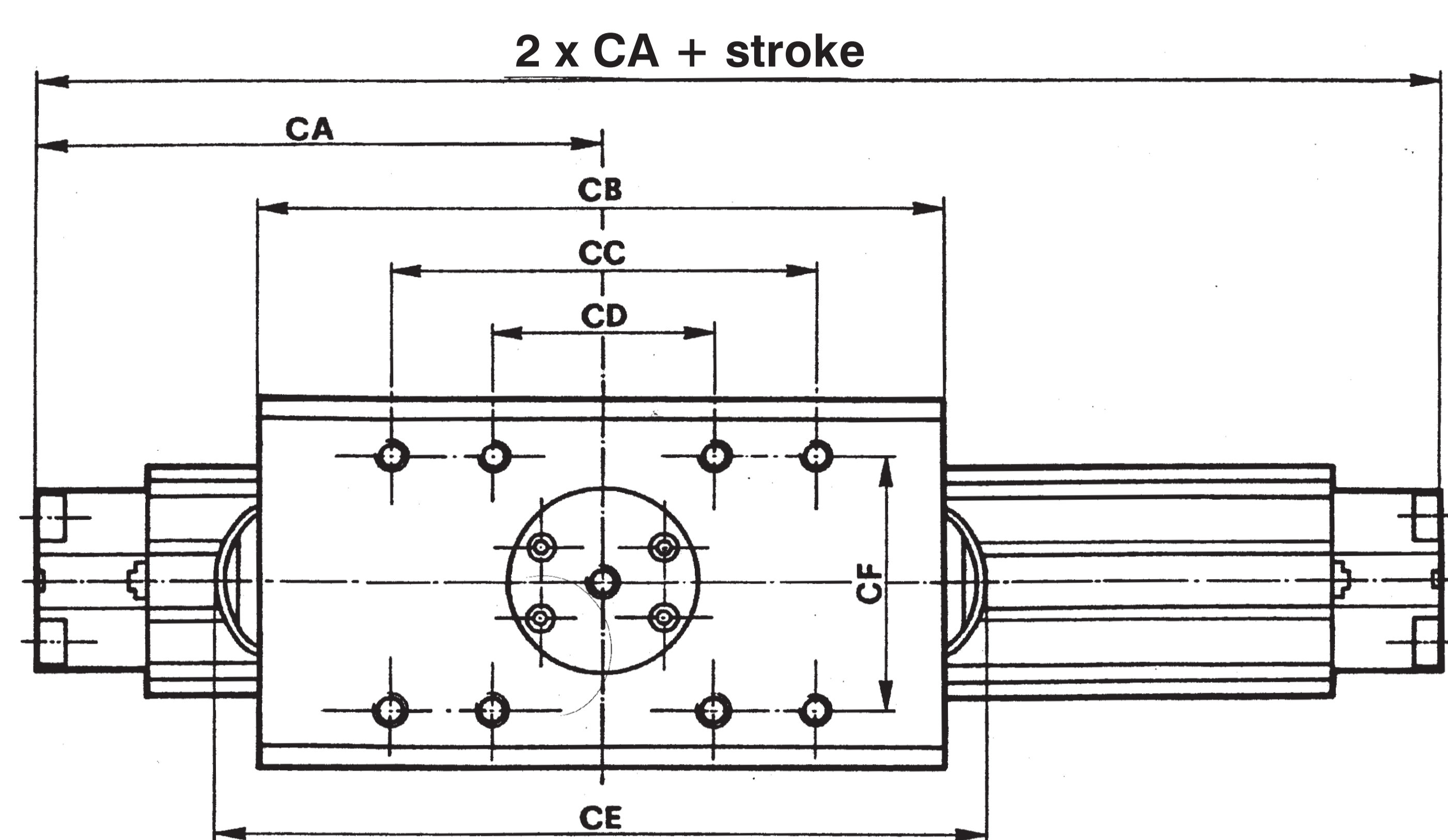

Cyl. Ø	CA	CB	CC	CD	CE	CF	Mass (kg) at "0" stroke
25	114,5	136	90	50	160	50	1,93
32	142,5	175	115	55	191	67,5	3,265
40	169	205	180	75	215	65	6,095
50	205	258	190	80	271	76,5	10,03

Long carriage - 12 fixing holes

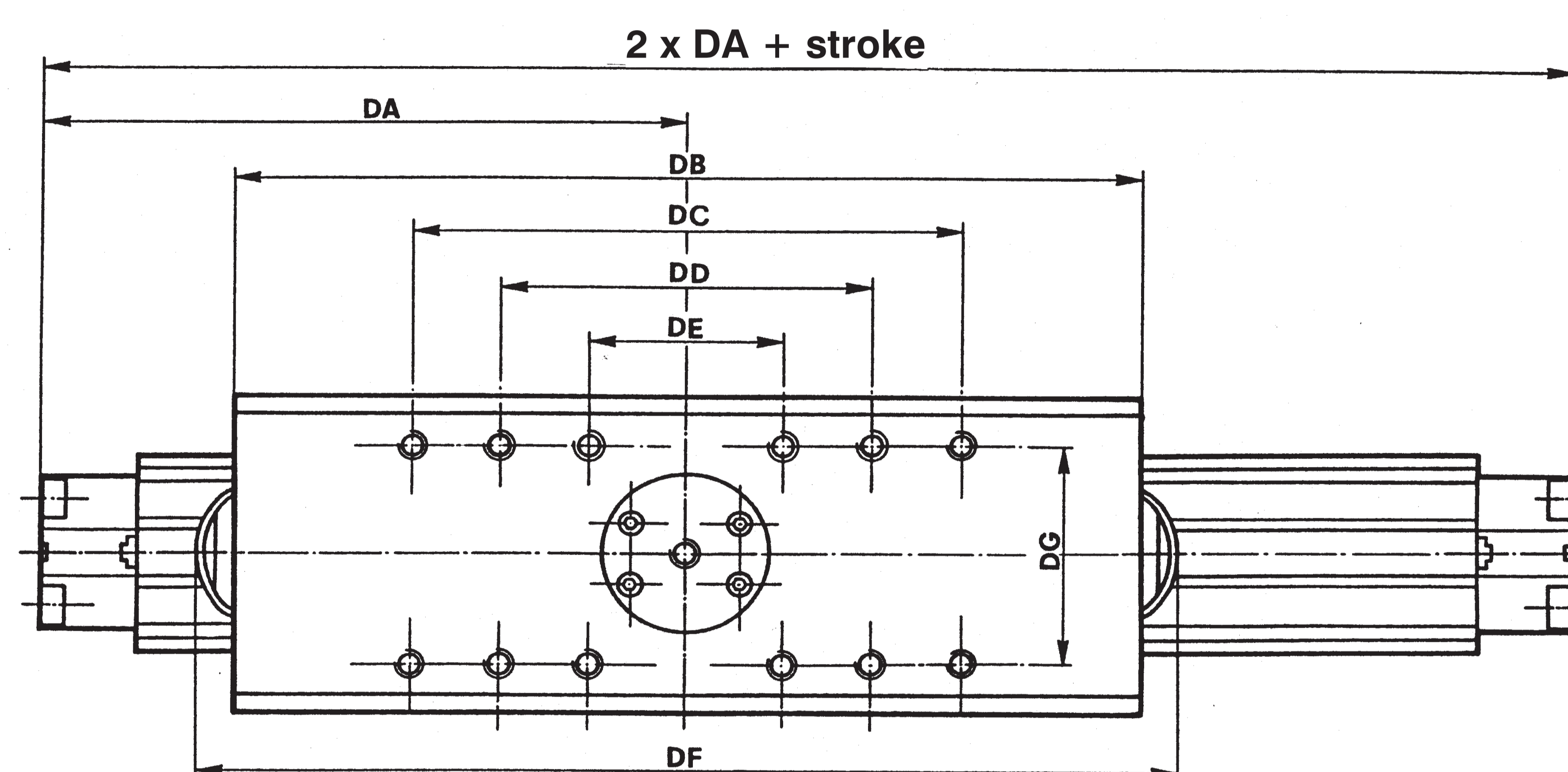

Cyl. Ø	DA	DB	DC	DD	DE	DF	DG	Mass (kg) at "0" stroke
25	147,5	201	130	90	50	225	50	2,64
32	190	270	175	115	55	286	67,5	4,65
40	225	317	280	185	75	327	65	8,60
50	277	398	320	200	80	411	76,5	14,04

Accessories from page 22.

Mounting plate for S1 series

Ø 16 mm

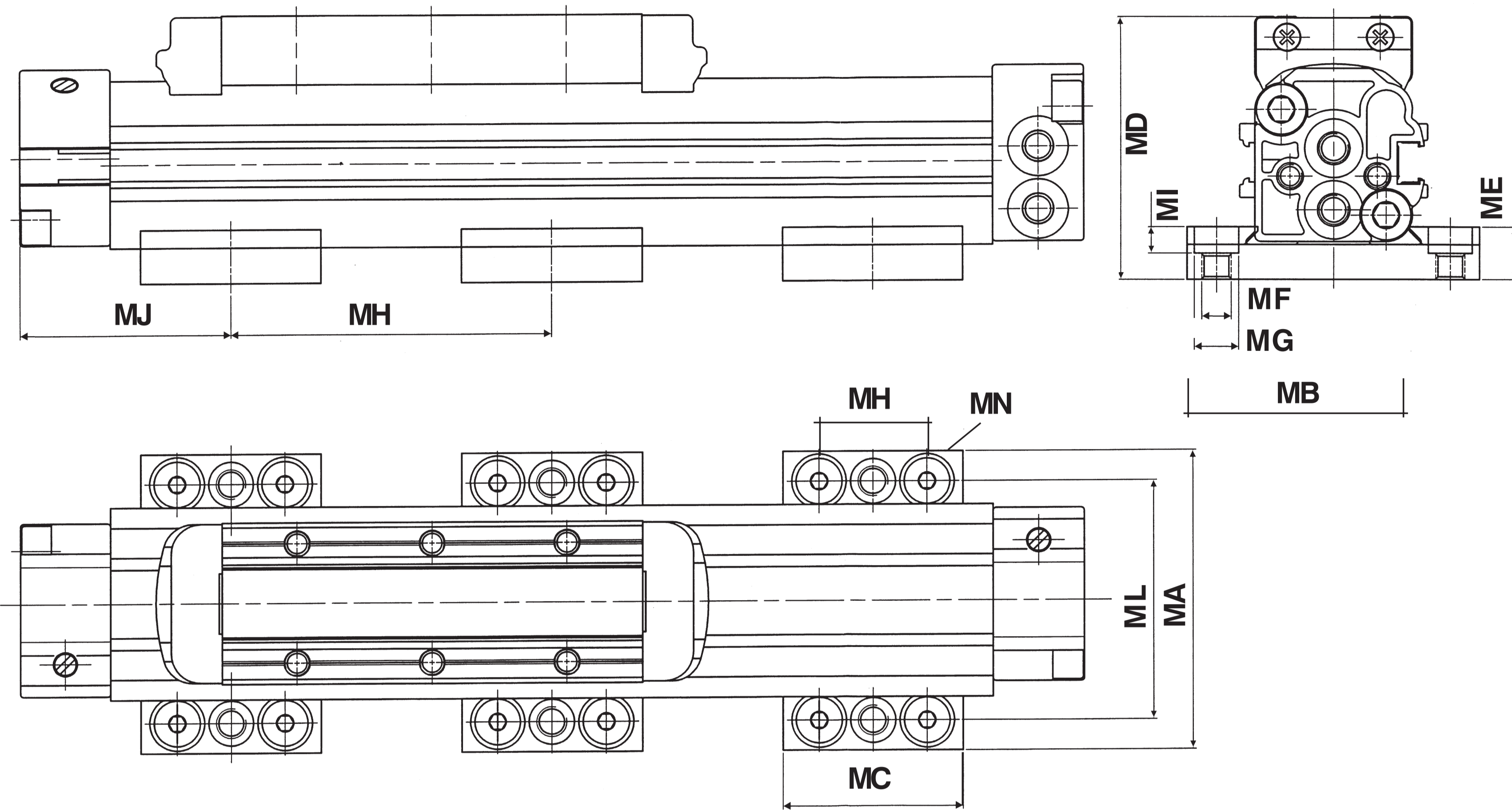

Ø 25 ÷ 50 mm

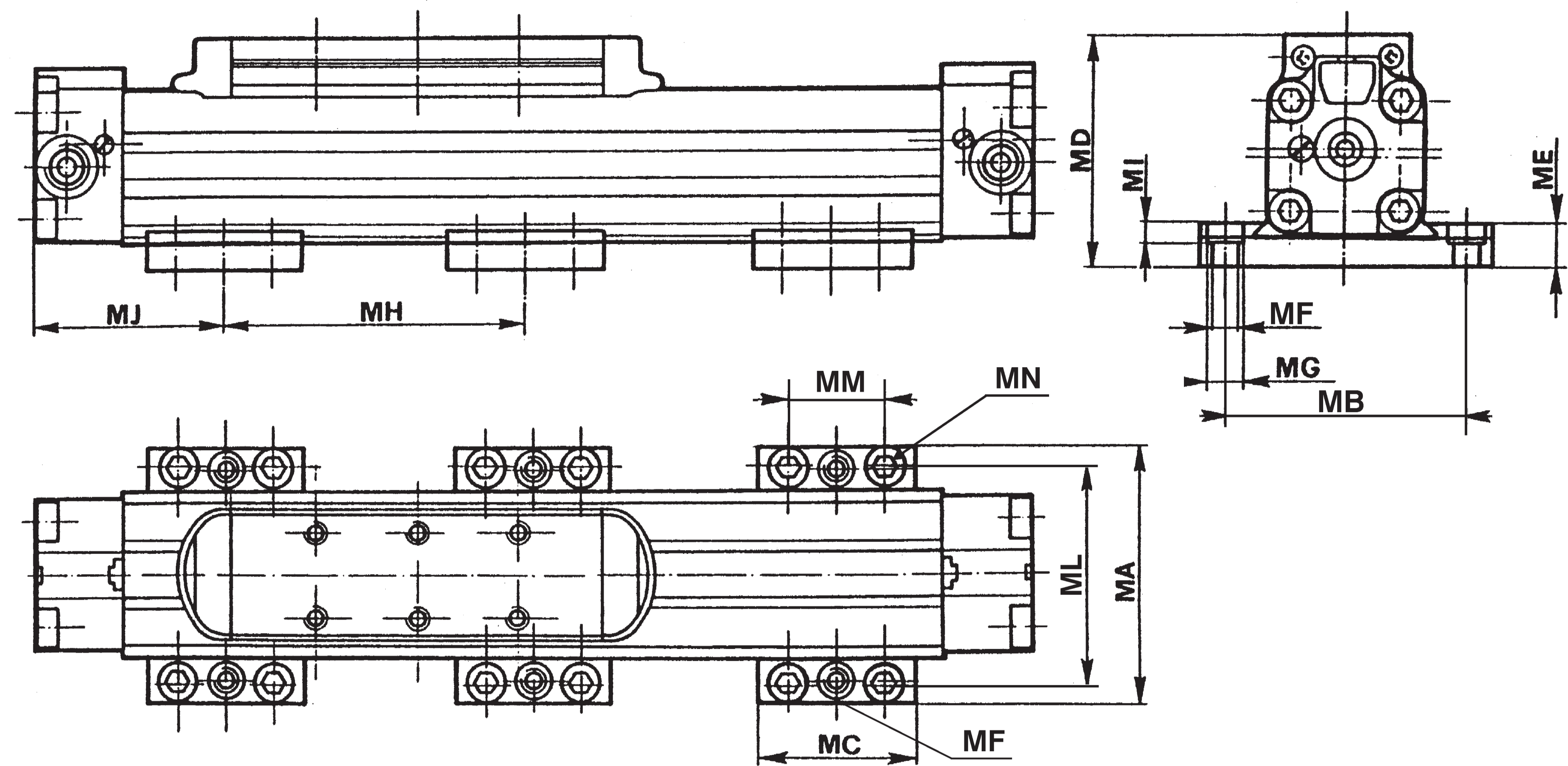

Cyl. Ø	MA	MB	MC	MD			ME	MF	MG	MH	MI	MJ	ML*	MM	MN	Mass (kg)	Part number
				S1	S5	VL1											
16	50	40	30	44,8	-	-	9	M5	8	400	4,5	35	40	-	M6	0,083	SF - 12016
25	78,5	63,5	50	65,6	79,8	82,3	12	M8	11	500	6,5	55	65,5	30	M6	0,310	SF - 12025
32	92	77,5	50	74,2	90,5	90,5	12	M8	11	600	5,5	60	79,5	30	M6	0,340	SF - 12032
40	117	96	60	95,8	116,6	116	15	M10	14	700	8	70	96	37,5	M8	0,660	SF - 12040
50	136	115	60	113	133,7	136,2	15	M10	14	800	8	70	115	37,5	M8	0,700	SF - 12050

◇ Max. dimensions in order to limit the deflection of the cylinder according to the stroke and in order to ensure a correct fixing.

* For Ø 16-40-50 mm, MB and ML have the same value.

Mounting plate for S5 Series

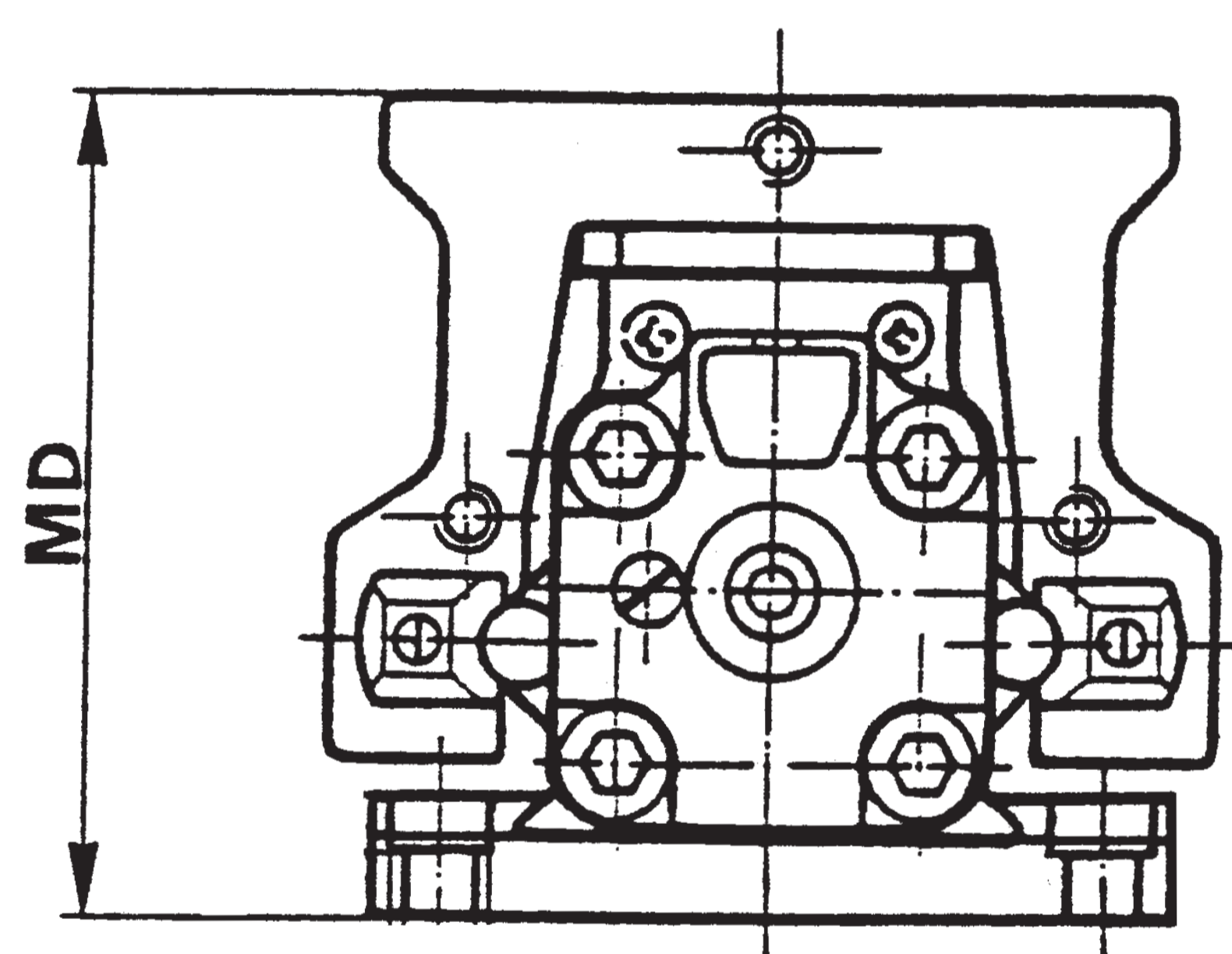

Mounting plate for VL1 Series

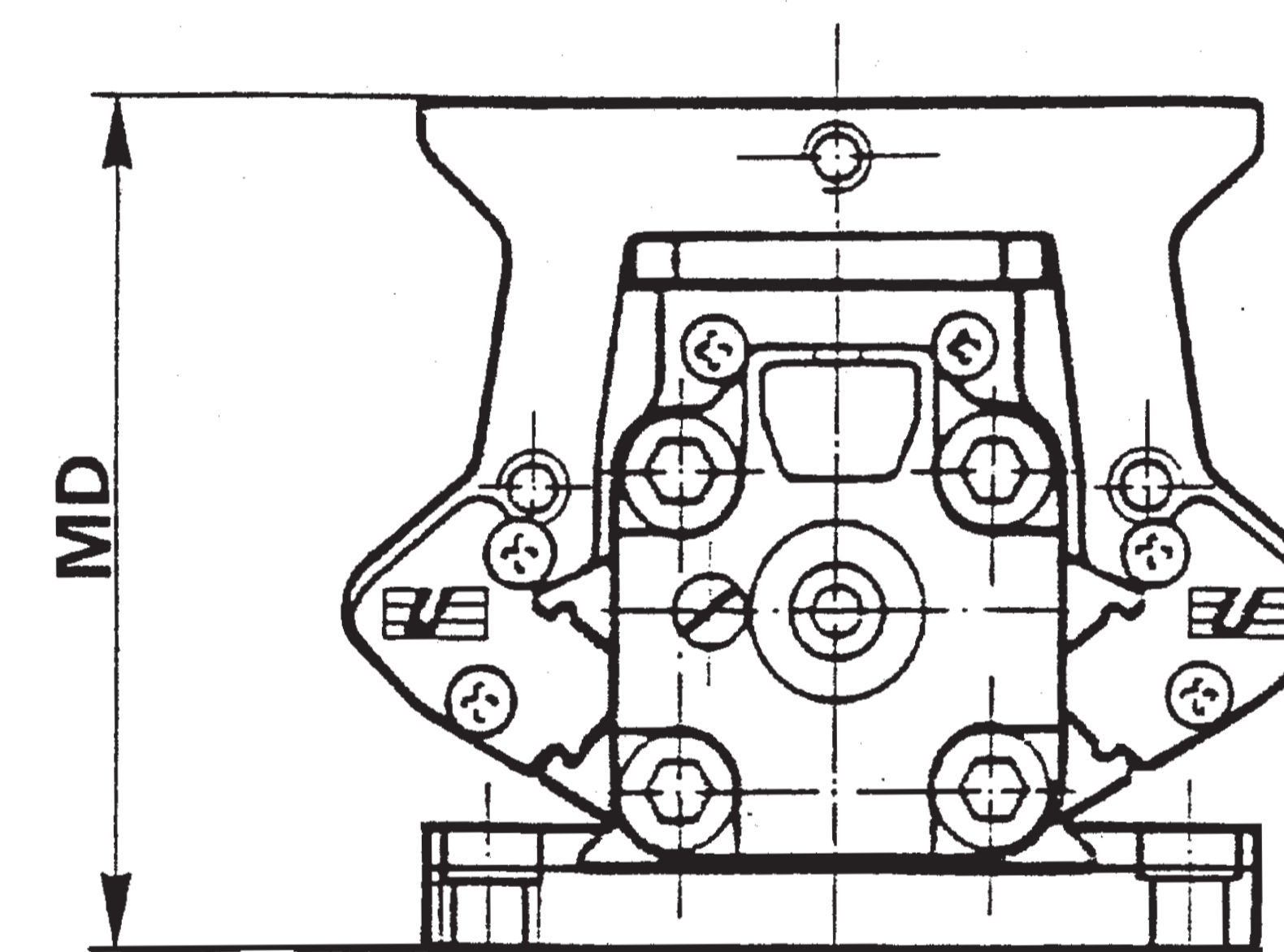

How to mount plates:

Plates are mounted by means of standard screws without disassembling any part of the cylinder (for all series).

Upper mounting

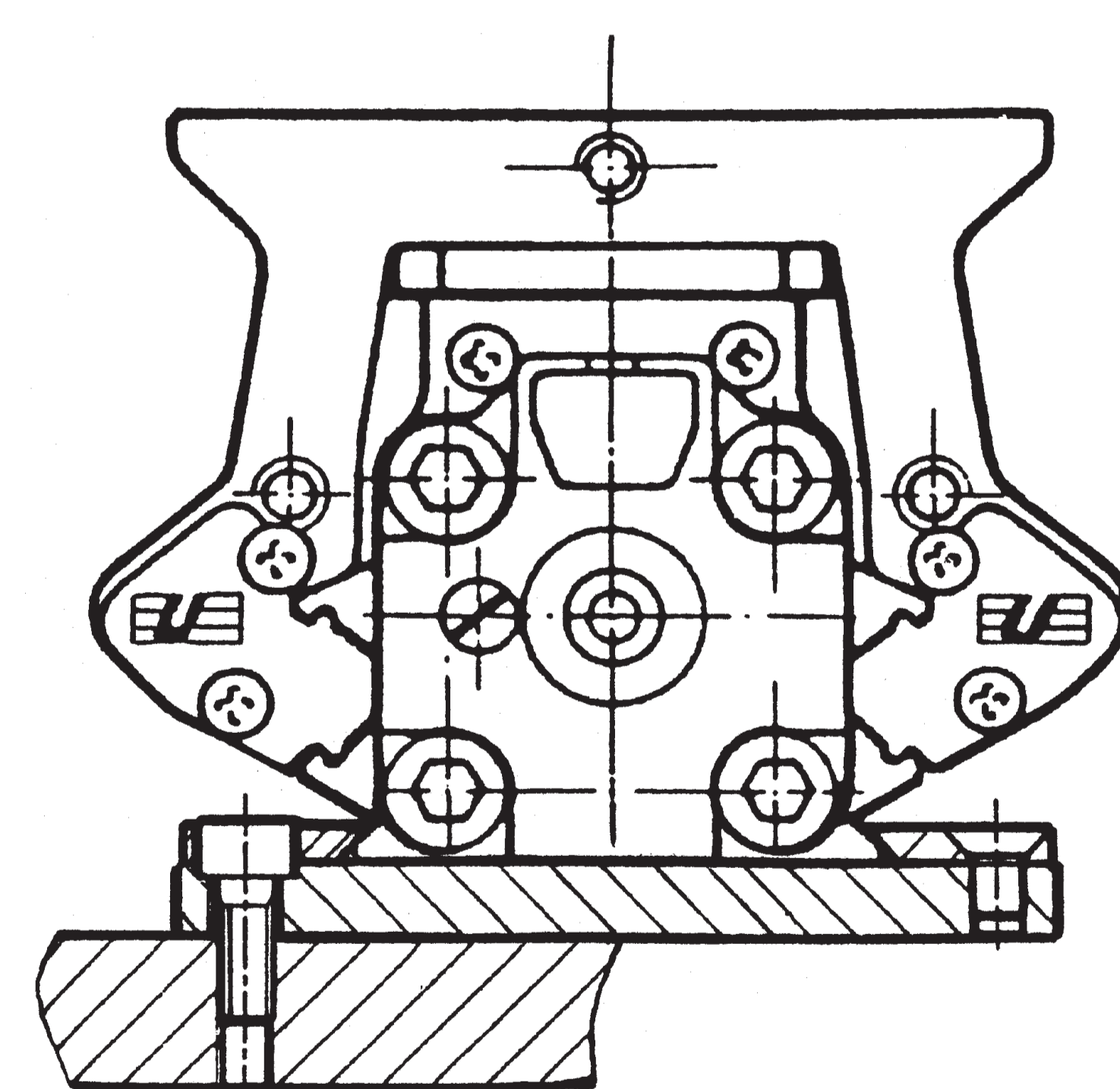

Cyl. Ø	
25 - 32	M6
40 - 50	M8

Lower mounting

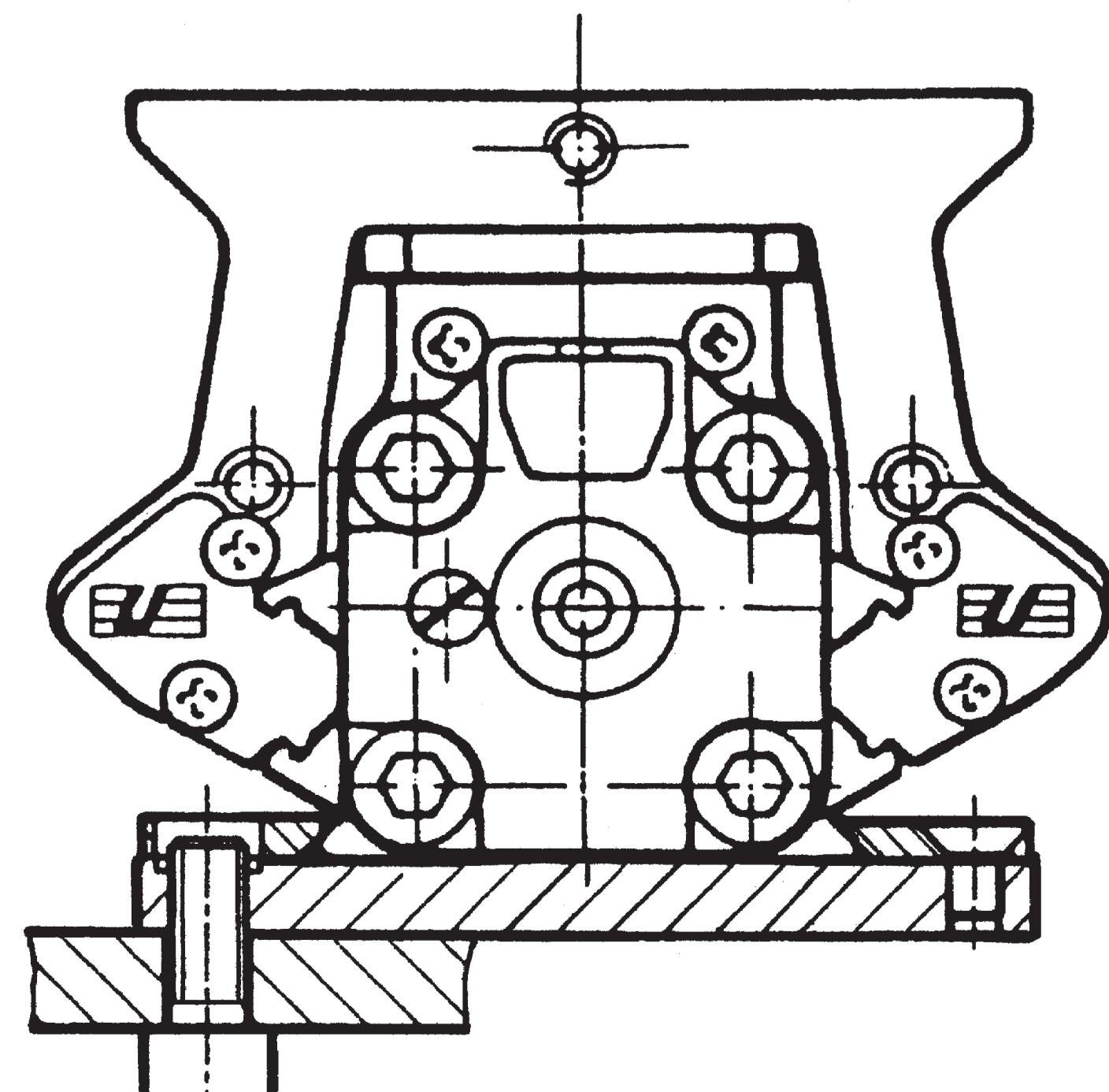

Cyl. Ø	
25 - 32	M8
40 - 50	M10

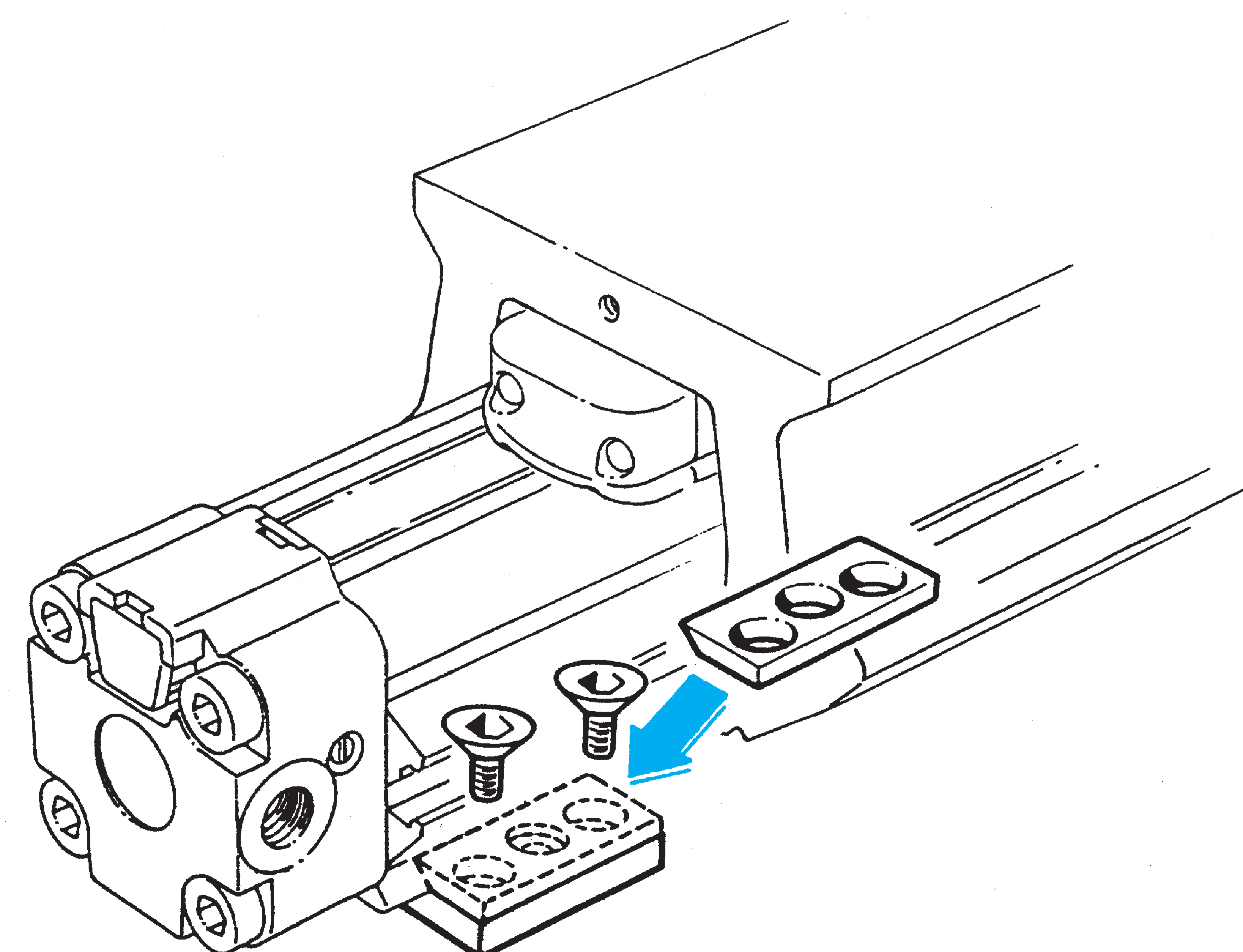

Mounting bracket for Ø 16 mm rodless cylinder
Part num. SF-13016

Mass kg 0,015

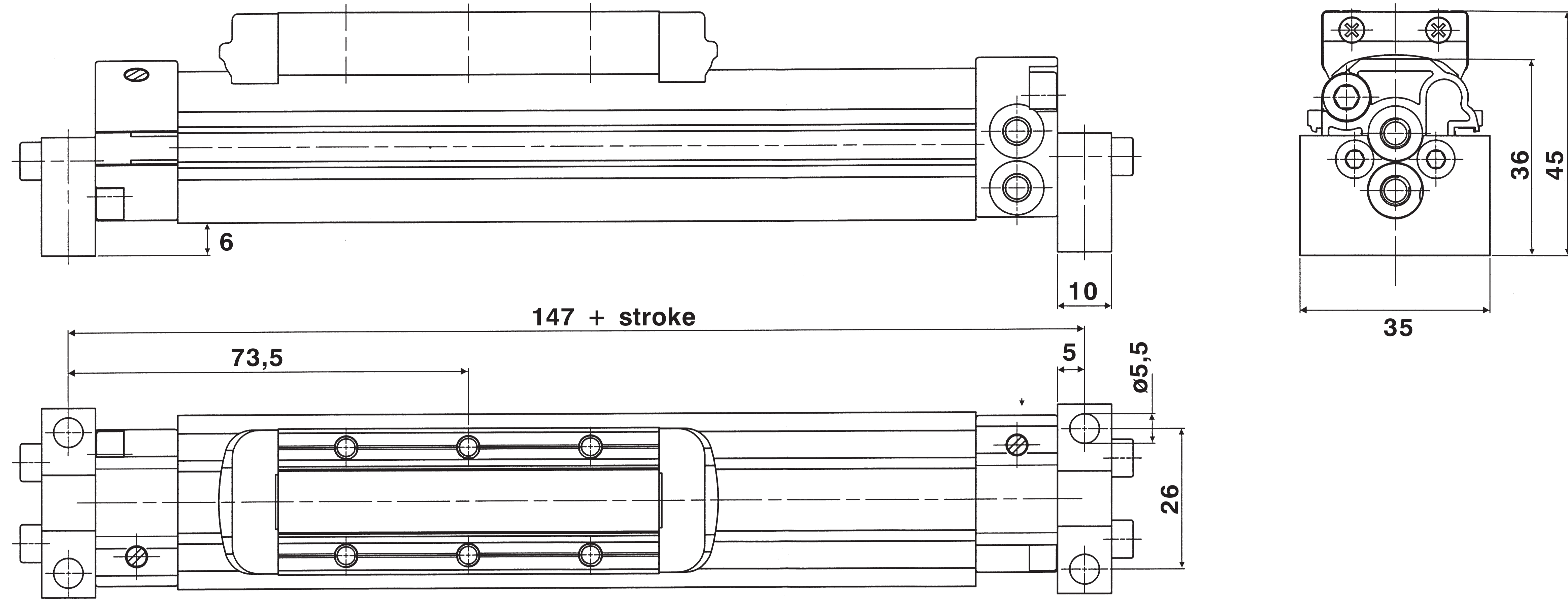

Mounting bracket for Ø 25 - 32 mm rodless cylinder

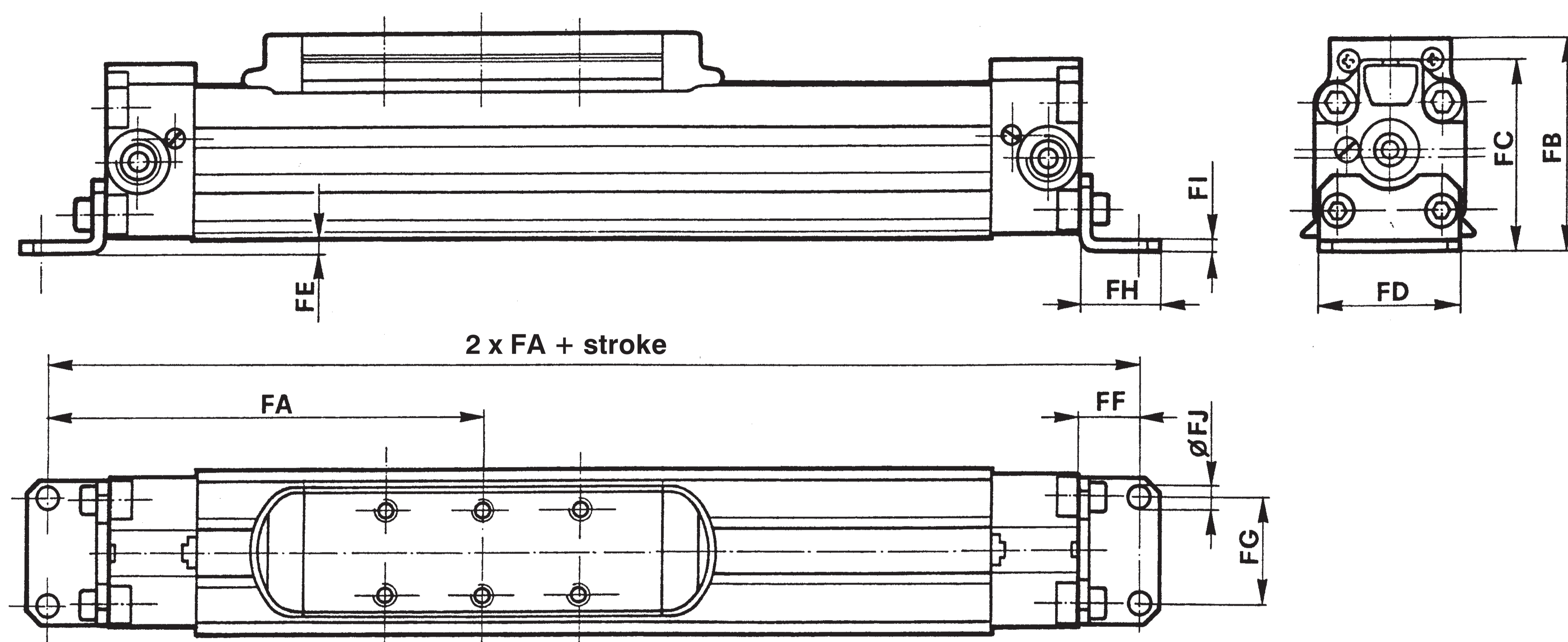

Mounting bracket for Ø 40 - 50 mm rodless cylinder

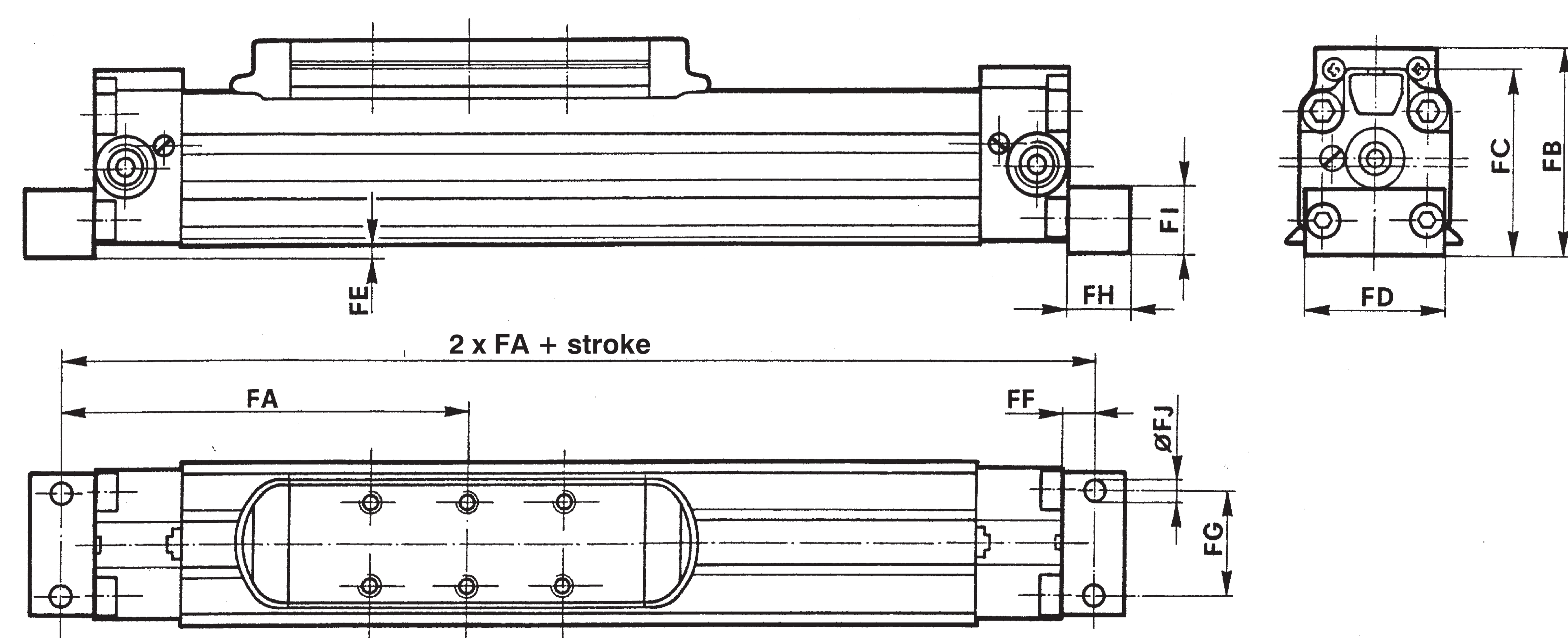

Cyl. Ø	FA	FB	FC	FD	FE	FF	FG	FH	FI	FJ	Mass (kg)	Part number
25	116	58,1	48,8	40	0,5	16	27	22	2,5	5,5	0,034	SF - 13025
32	143,5	68,7	59,2	48	2,5	18,5	36	26	3	6,5	0,053	SF - 13032
40	162,5	86,5	74,9	63	0,7	12,5	30	25	25	9	0,116	SF - 13040
50	189,5	104,3	92,4	79	1,3	12,5	40	25	30	9,3	0,170	SF - 13050

Mounting brackets are ONLY recommended for short strokes i.e. less than 400 mm

Oscillating mounting bracket

Ø 16 mm
Part numb. SF-24016

Mass Kg 0,195

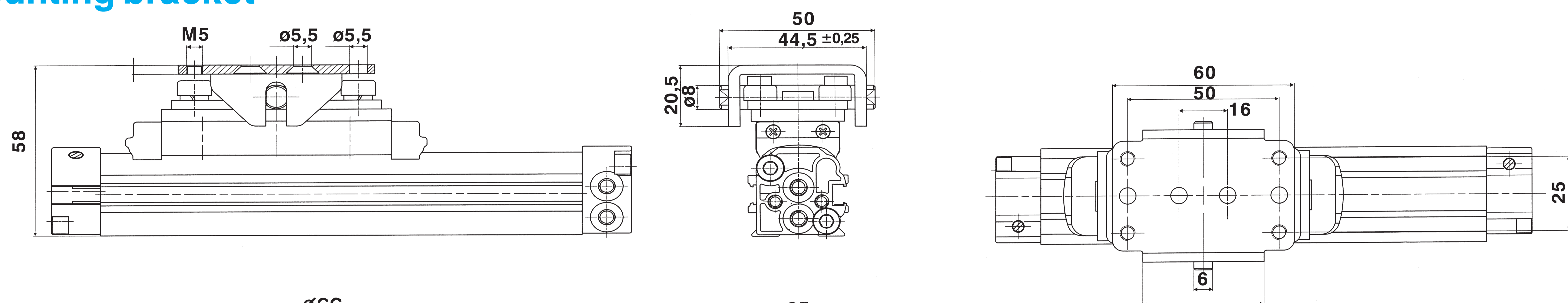

Ø 25 ÷ 50 mm

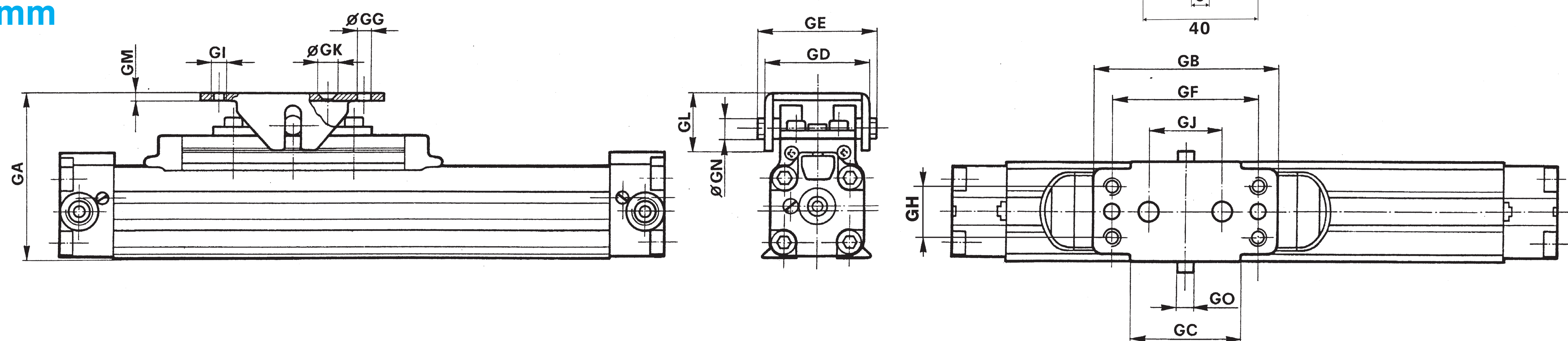

Cyl. Ø	GA	GB	GC	GD	GE	GF	GG	GH	GI	GJ	GK	GL	GM	GN	GO	Mass (kg)	Part number
25	73,5±2,5	60	40	44,5±2,5	50	50	5,5	25	M5	16	5,5	20,5	3	8	6,15	0,142	SF - 24025
32	89±4	100	60	56±4	64	80	5,5	30	M6	40	6,5	30	4	12	8,2	0,362	SF - 24032
40	108,5±4	100	60	56±4	64	80	5,5	30	M6	40	6,5	30	4	12	8,2	0,362	SF - 24032
50	not foreseen																

Female threaded connection

Ø 16 mm

Mass
Kg 0,132

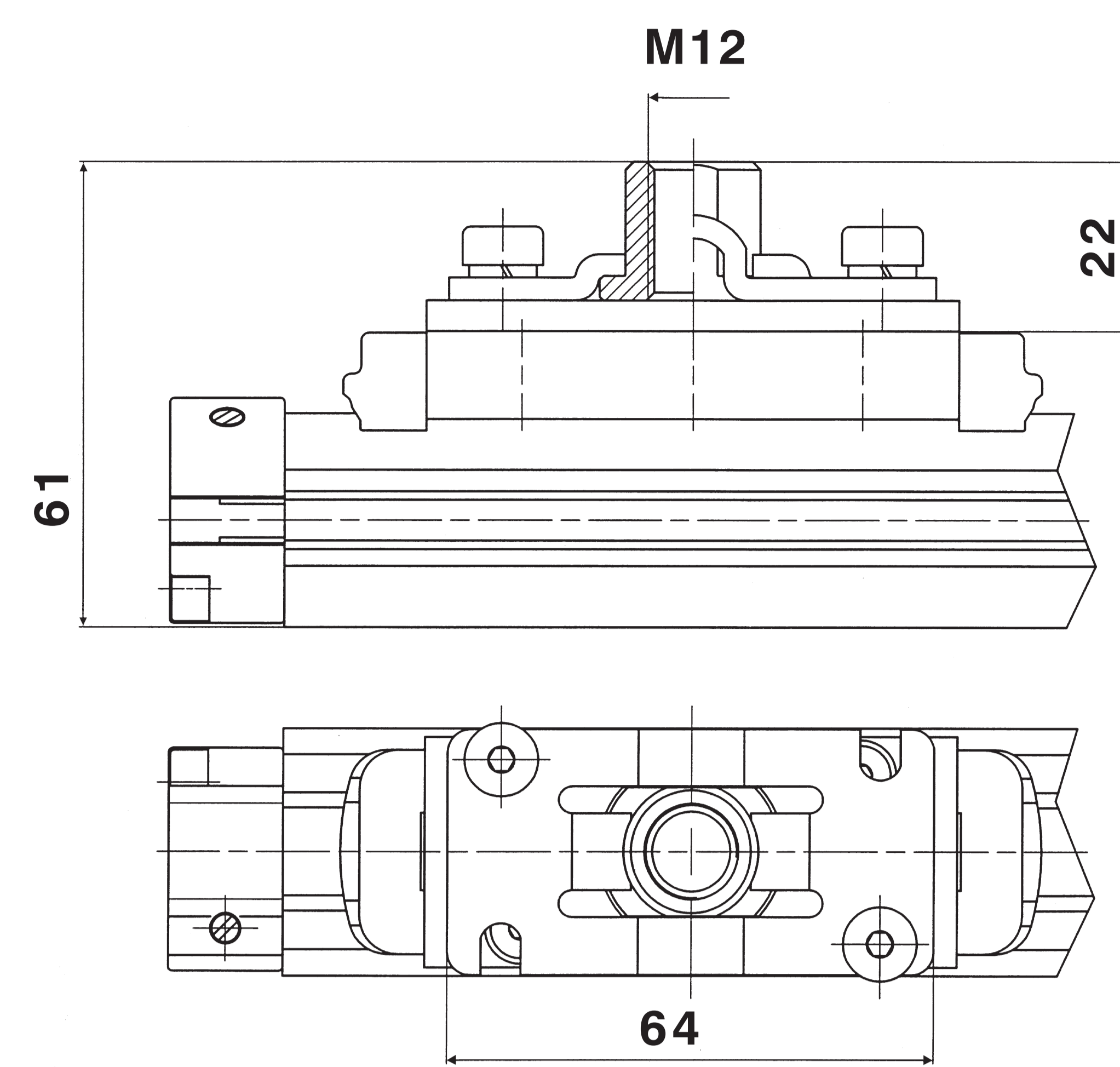

Ø 25 ÷ 50 mm

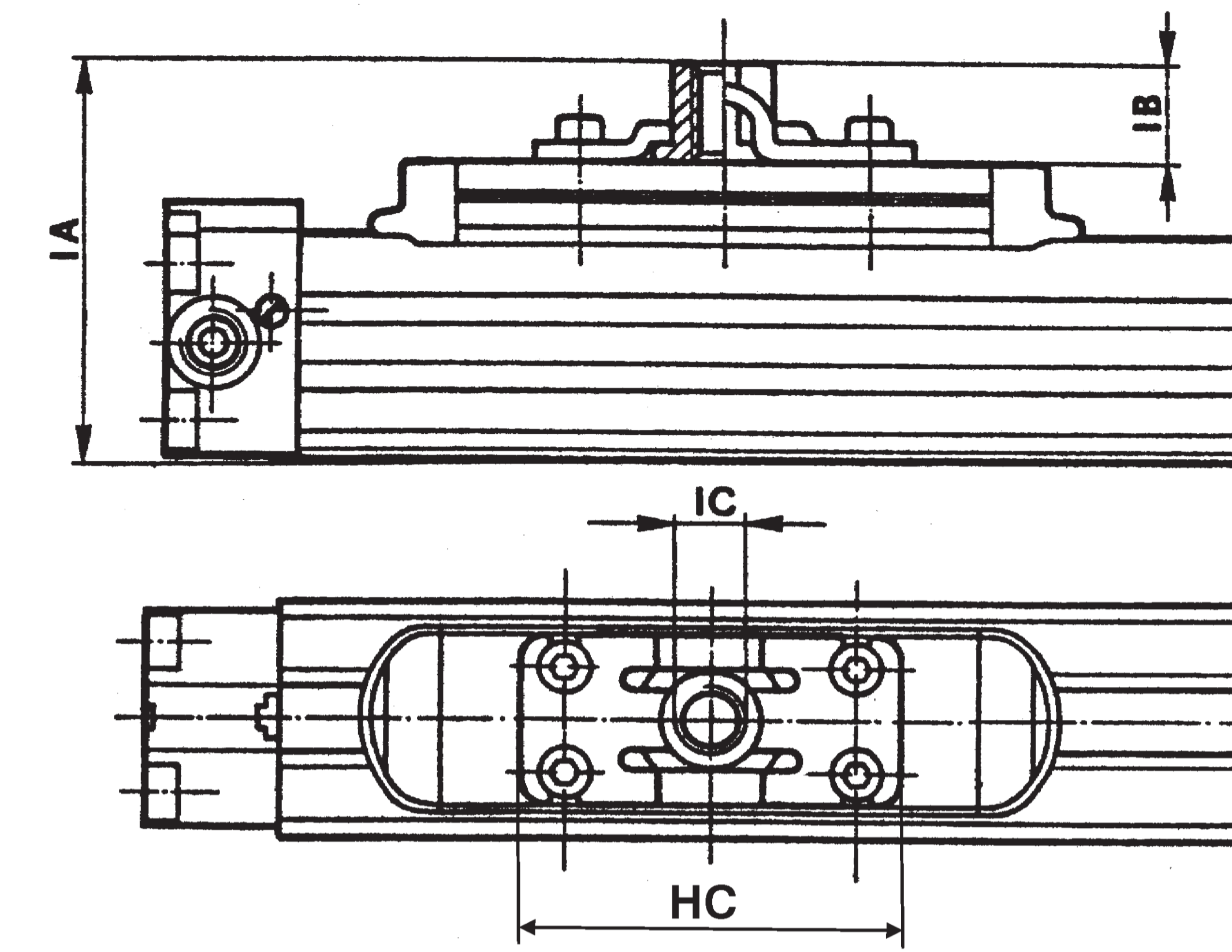

Cyl. Ø	IA	IB	IC	HC	Mass (kg)	Part number
25	75,6	18	M12	64	0,076	SF-26025
32	87,2	21	M14	84	0,157	SF-26032
40	106,8	21	M14	84	0,157	SF-26032
50	not forseen					

Female connection without thread

Ø 16 mm

Mass
Kg 0,129

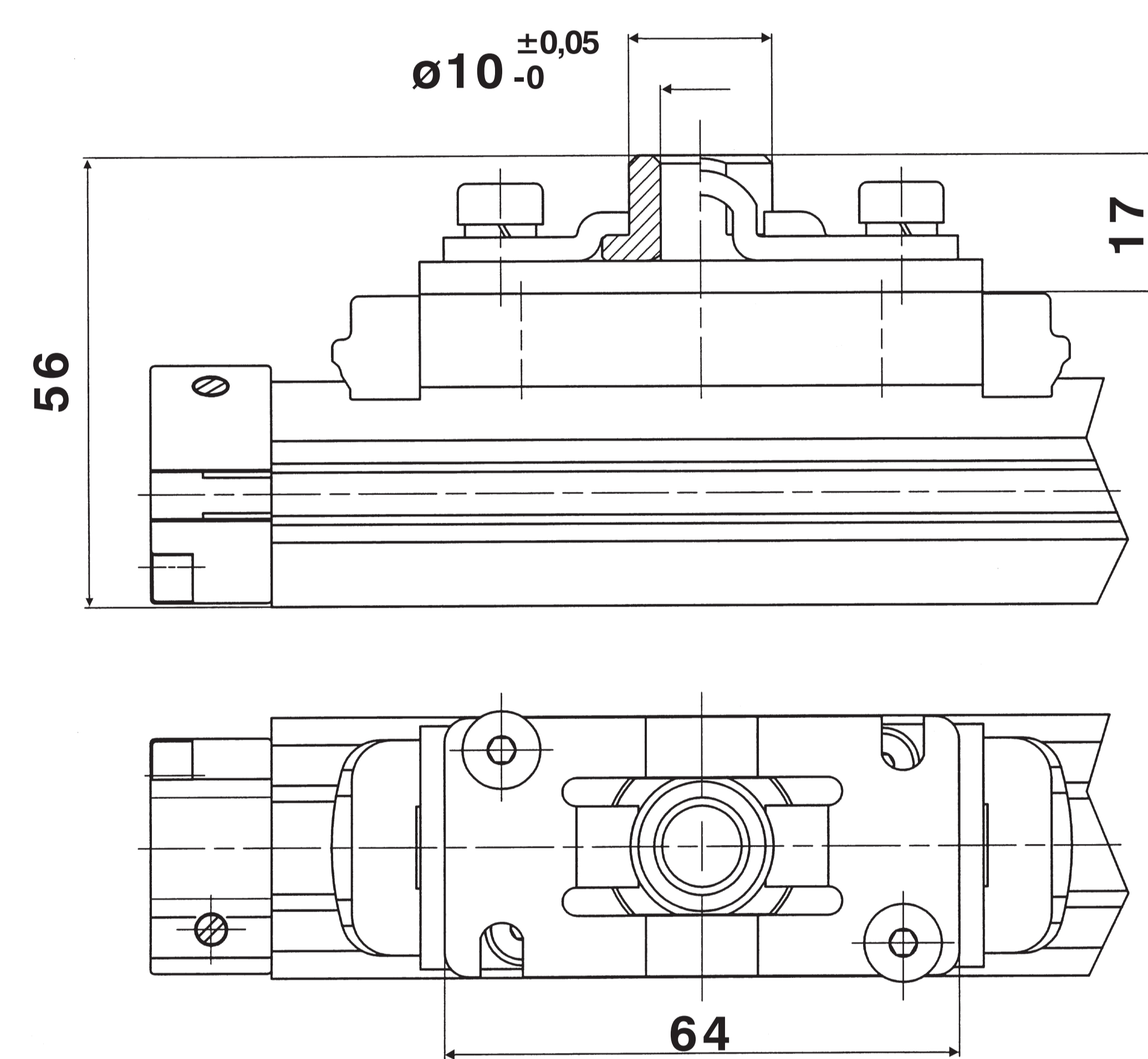

Ø 25 ÷ 50 mm

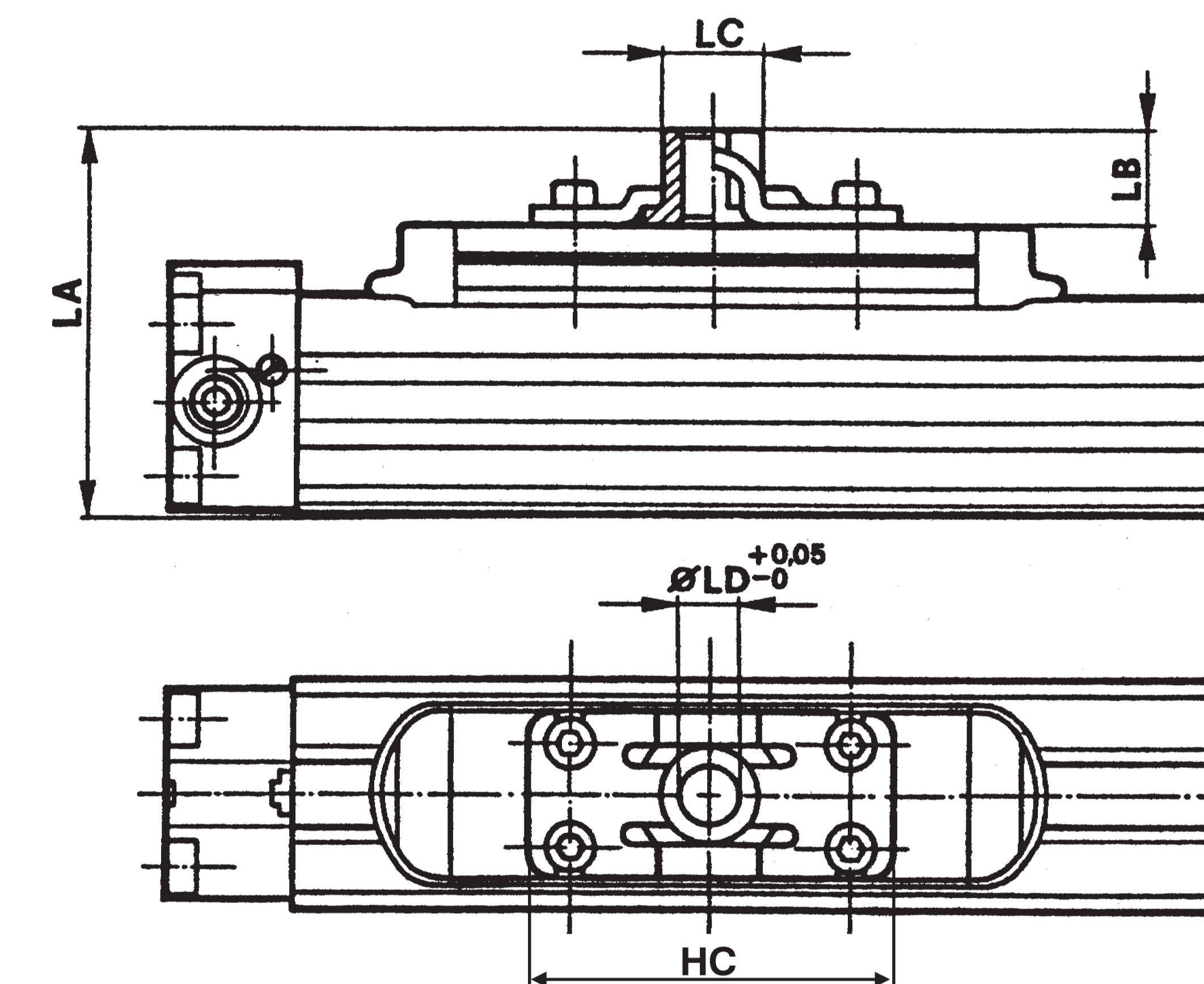

Cyl. Ø	LA	LB	LC	LD	HC	Mass (kg)	Part number
25	70,6	13	18	10	64	0,073	SF-28025
32	83,4	17,2	22	12	84	0,152	SF-28032
40	103	17,2	22	12	84	0,152	SF-28032
50	not forseen						

Male threaded pin

Ø 16 mm

Mass
Kg 0,160

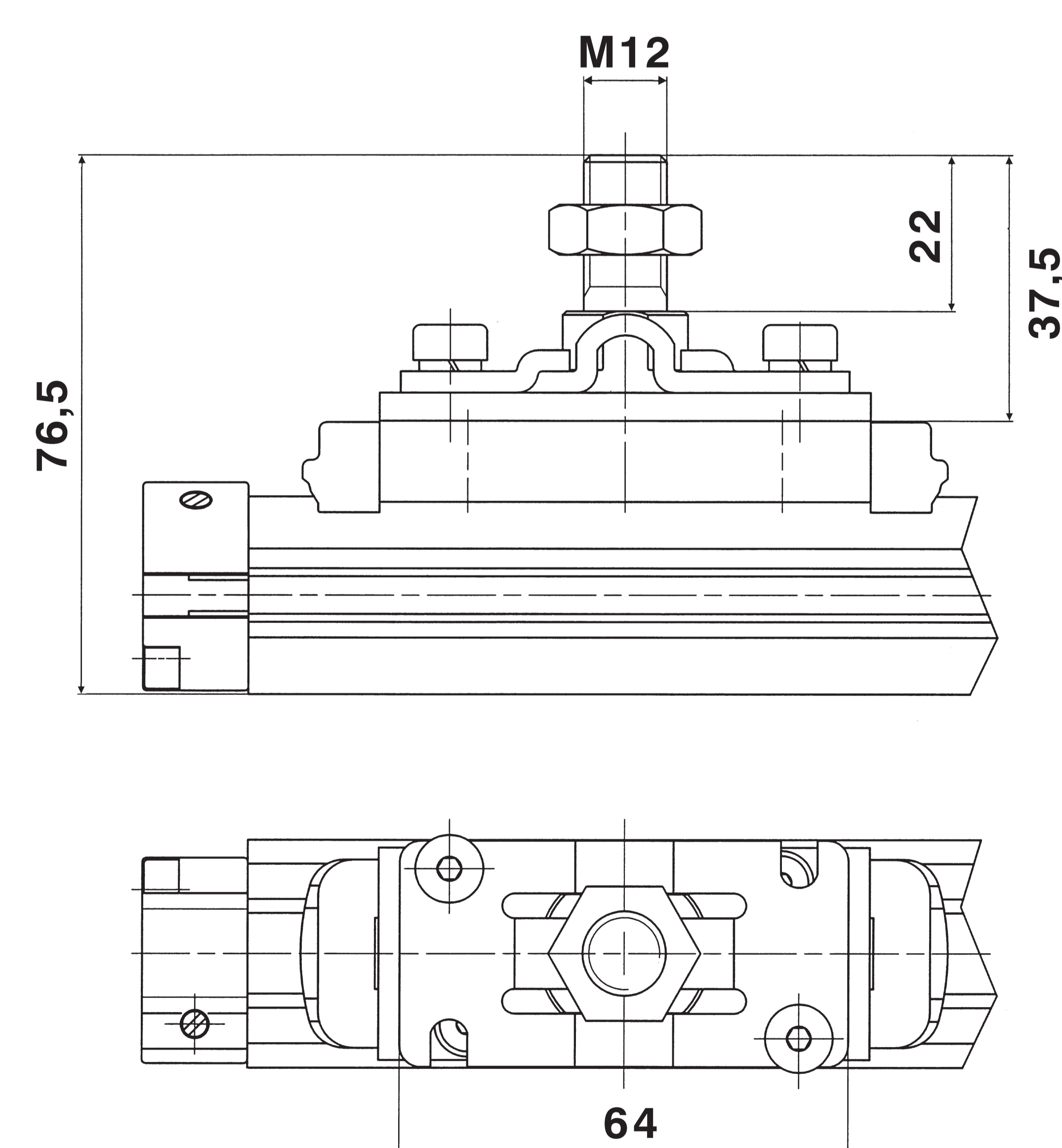

Ø 25 ÷ 50 mm

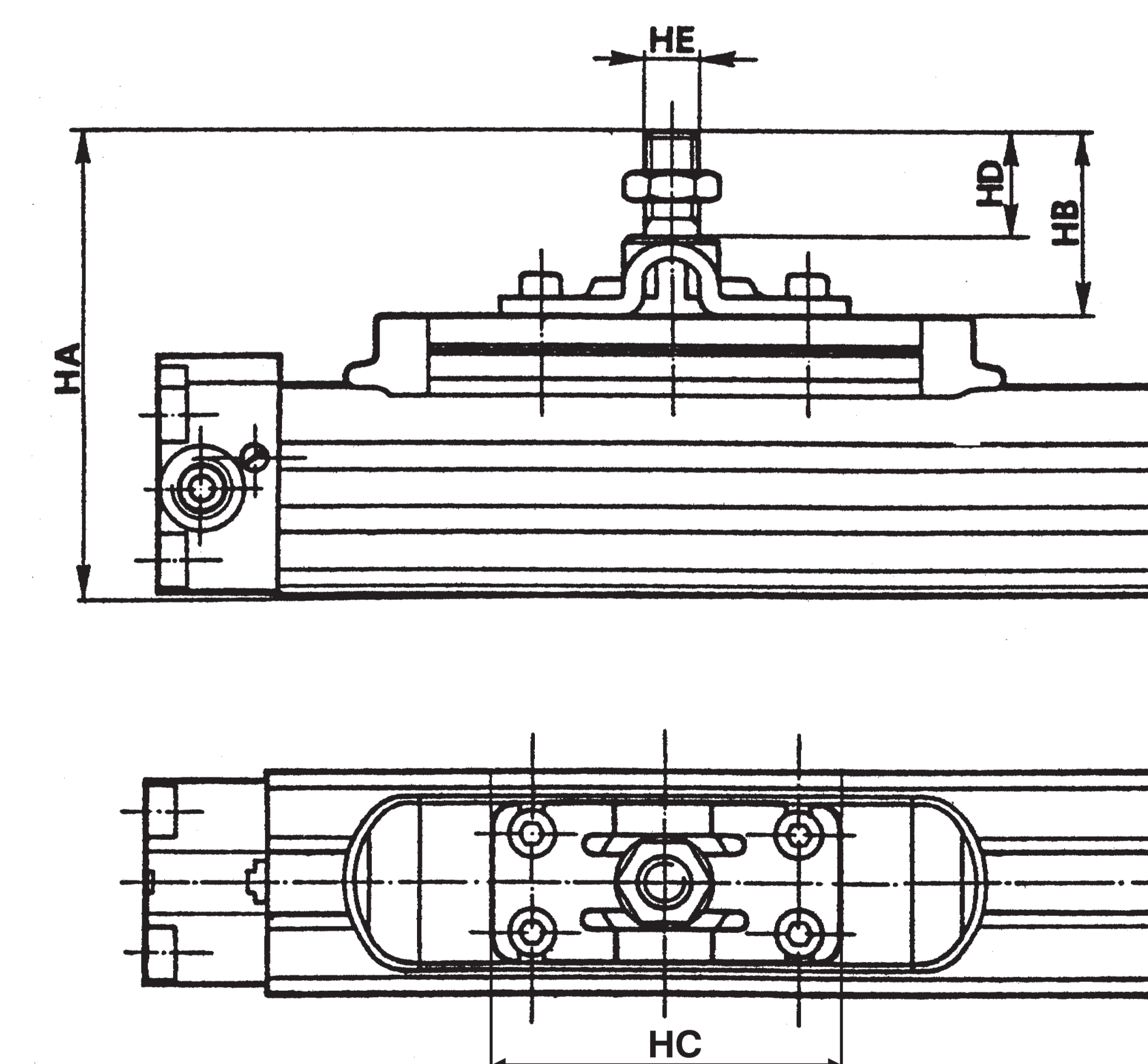

Cyl. Ø	HA	HB	HC	HD	HE	Mass (kg)	Part number
25	91,1	33,5	64	22	M12	0,105	SF-27025
32	107,7	41,5	84	24,3	M14	0,26	SF-27032
40	127,3	41,5	84	24,3	M14	0,26	SF-27032
50	not forseen						