

This product is the result of having linked to a pneumatic actuator both the digital position detector and the integrated safety locking system.

The system does not need to be connected to the moving part of the mechanism as it generates by itself the movement by means of an internal pusher with bidirectional pneumatic function. This pusher, operated by a 5-way microvalve, moves autonomously until it meets the obstacle and measures the position.

The detection of the position is obtained by transforming the translation movement of the piston rod in a rotation movement of the screw (fig. 2) by means of the coupling of screw-female screw (fig.1); the encoder transforms the rotation (mechanical size) in sequences of electric pulses and establishes the relation between number of turns and number of pulses.

The piston and the body of the encoder of the actuator must necessarily be fixed, i.e. must not move as regards to the rotation of the screw and for this reason has been used the cylinder with octagonal piston and non-rotating piston rod adequately modified.

Fig. 1

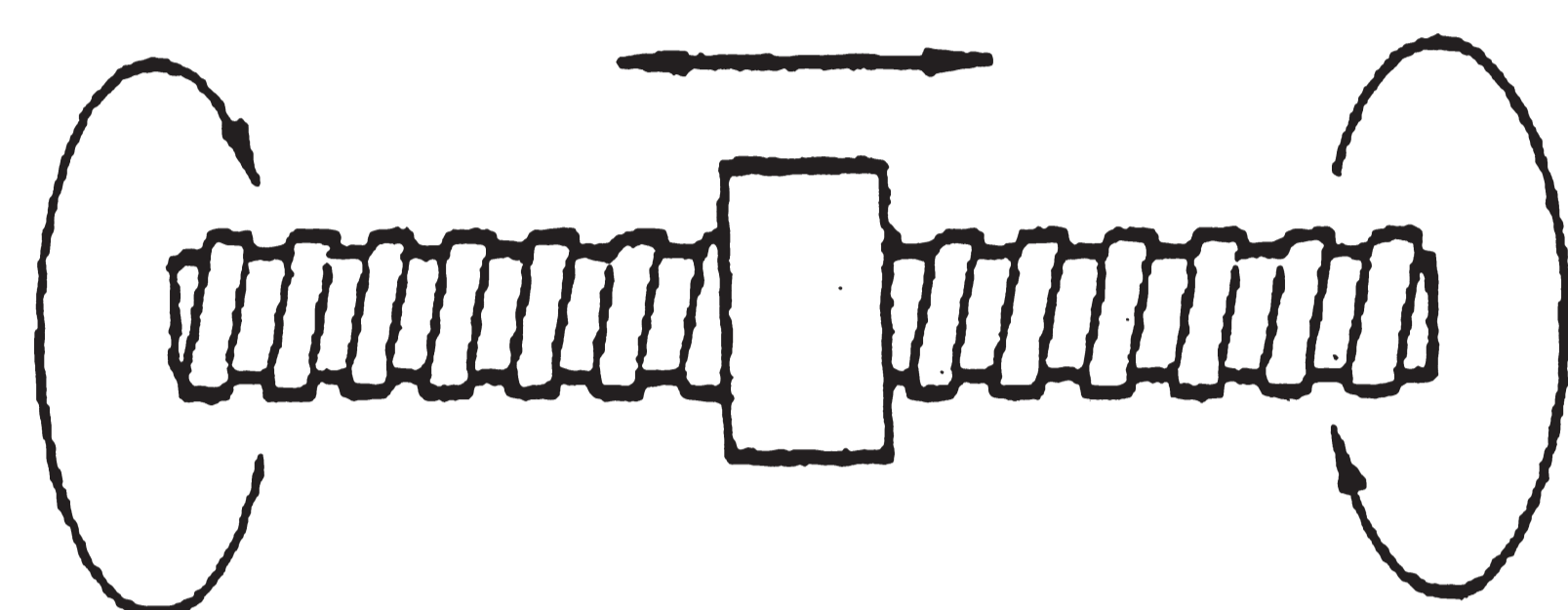
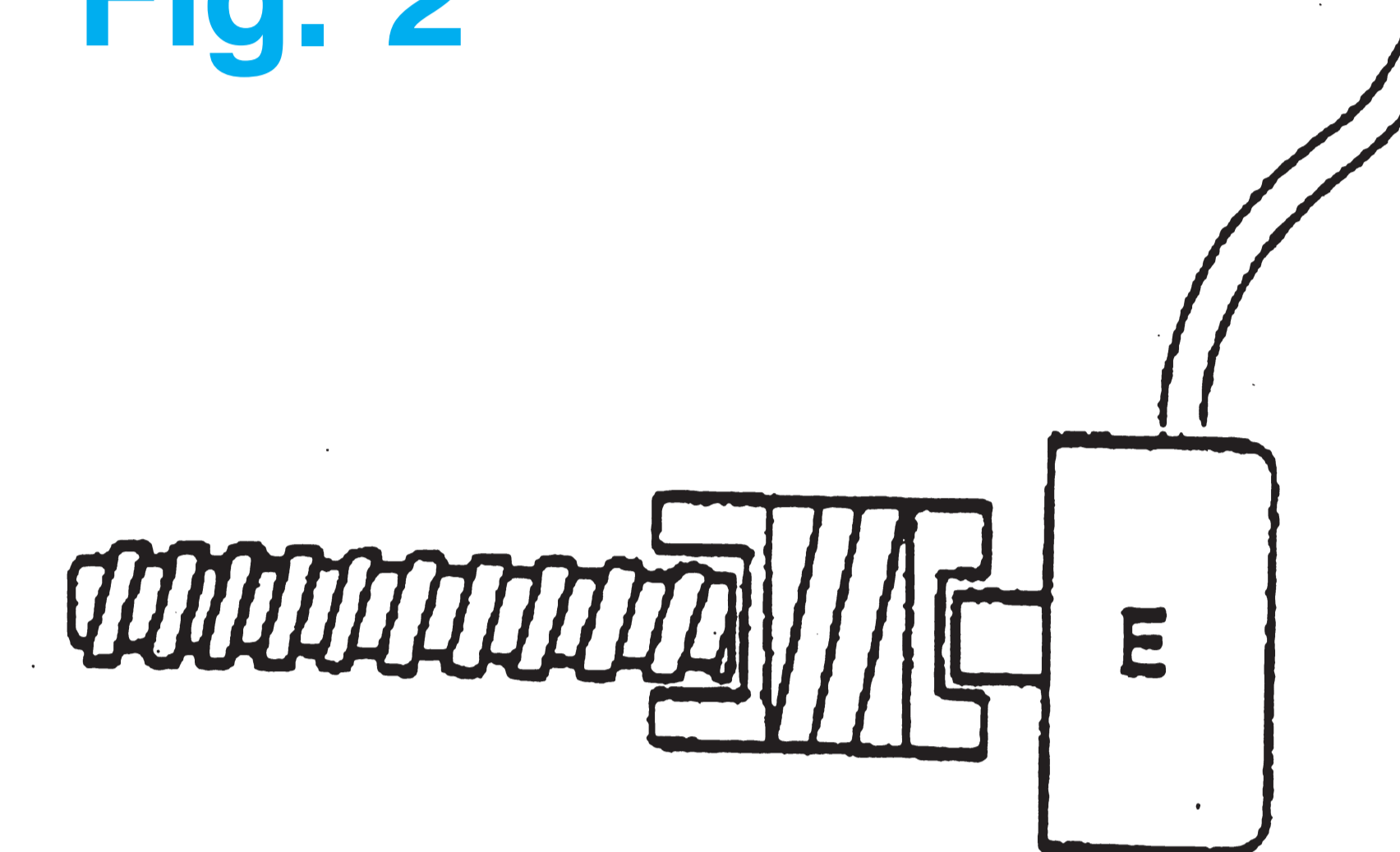

Fig. 2



The speed of the impact against the obstacle is limited by appropriate calibrated reducers which are built into the detector, whilst it is possible to adequately regulate the translation speed by means of a normal pressure regulator. In order to guarantee a reading with the indicated repeatability, the translation speed must be as constant as possible.

The main sectors of application are:

Mechanization, palletization, automation of operating machines.

Codification key

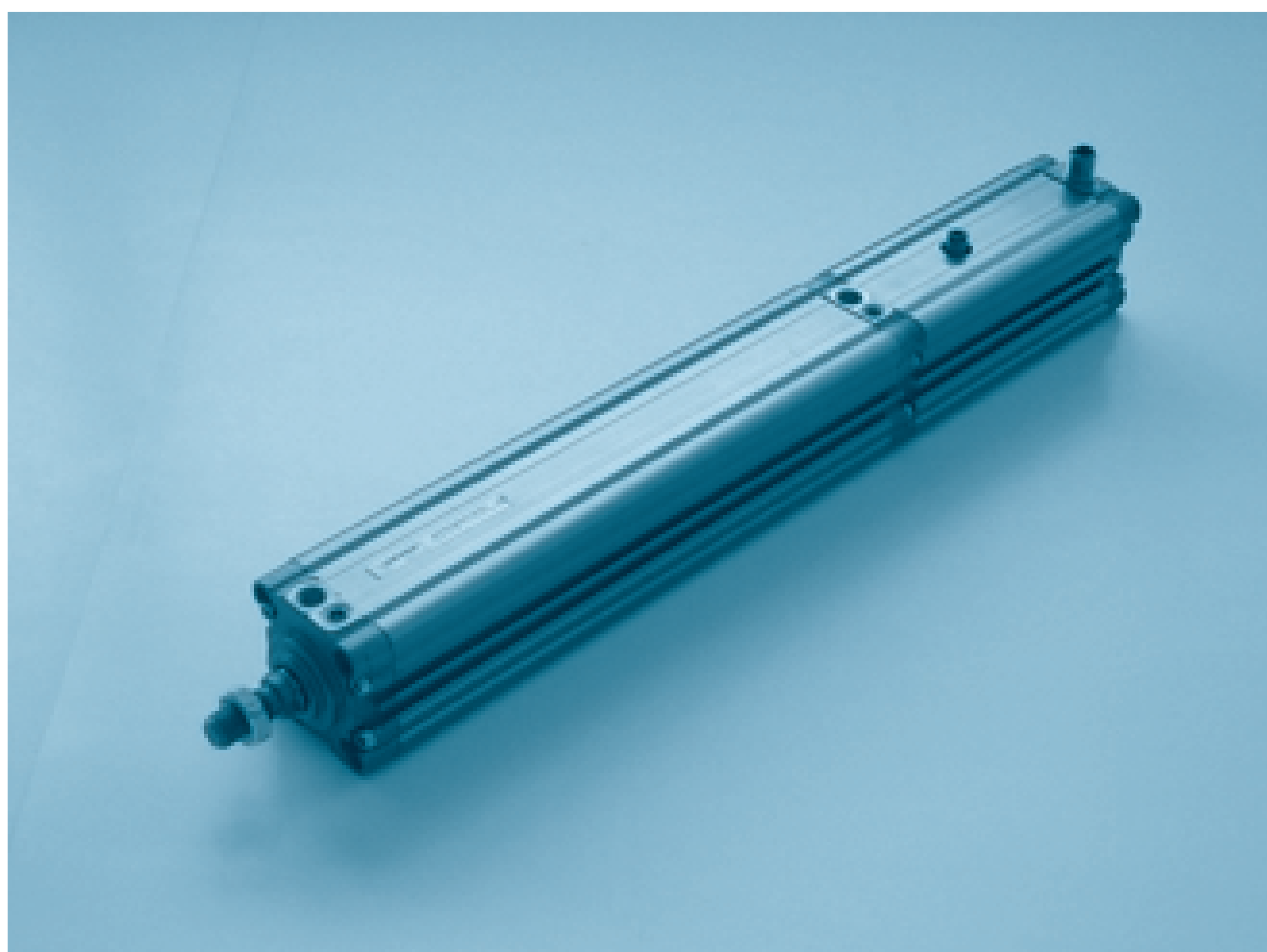
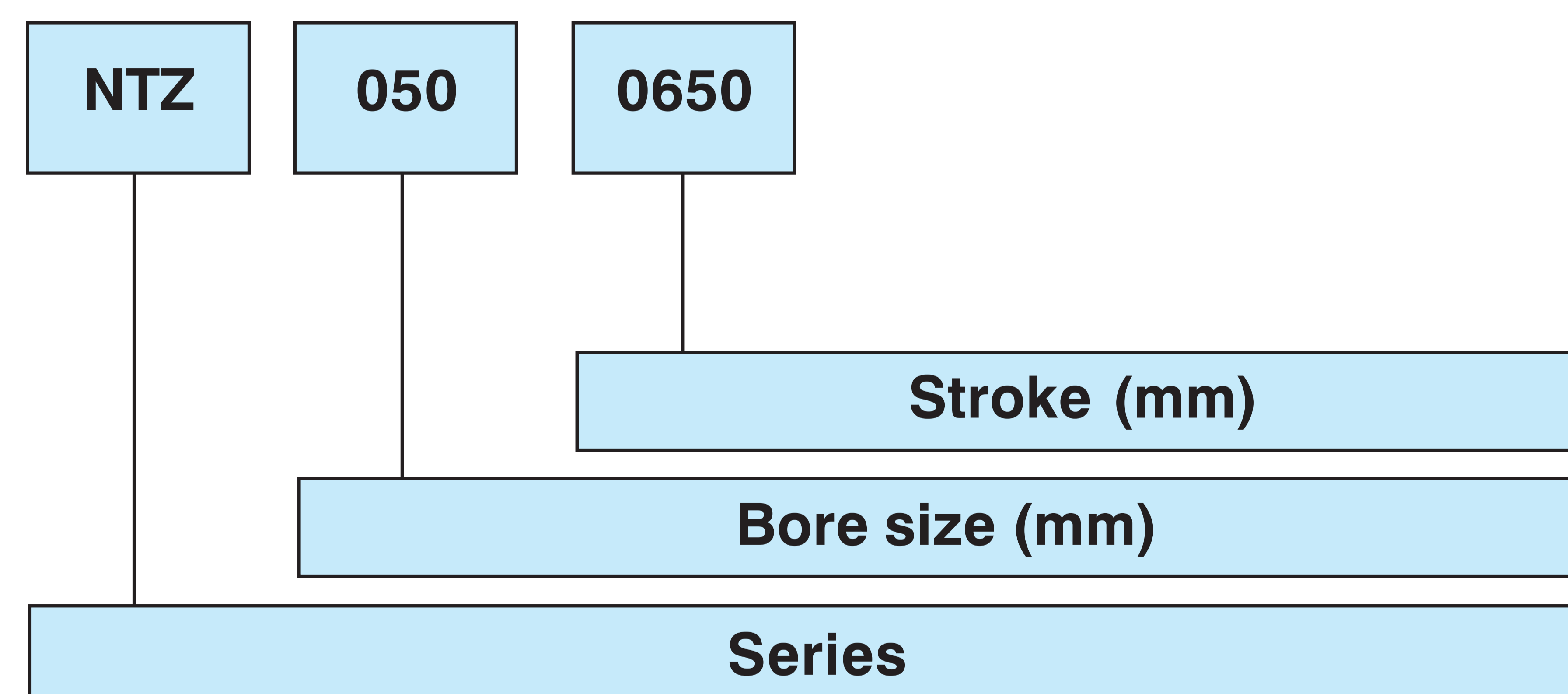

SERIES

NTZ= Programmable pneumatic actuator with integrated safety locking system.

BORE SIZE

032 - 040 - 050 - 063 mm

MAX. STROKE

350 mm for Ø 32
450 mm for Ø 40
650 mm for Ø 50
700 mm for Ø 63

N.B. When the detector is used in environments with electromagnetic disturbances exceeding those allowed by the EN50081-2 standard, also request the adapter TAE011A10305 (our production) or suppressors of electromagnetic interferences available on the market.

Technical characteristics

Working pressure	2 ÷ 10 bar
Ambient temperature	-10 ÷ 70°C
Fluid	filtered air 30 μm
Bore size	032 - 040 - 050 - 063 mm
Standard stroke	depending on bore size (refer to codification key)
Barrel	extruded barrel in aluminium alloy with groove for flush-mounted sensors
Piston rod	chromium-plated steel
Functioning of the locking unit	passive, in the absence of signal and/or air supply
Min. pressure	> 3 bar
Holding force of the piston-rod	> 3 times the thrust of the cylinder with air supply 6 bar
Max. speed	1 m/s
Precision of repeatability	± 0,3 mm

Electrical characteristics

Air supply	5 Vdc
Output	Level "L" < 0,5V Level "H" Vdc
Limit frequency	60 KHz
Impedance	2 Kohm
Consumption of current	40 mA max
Time of upstroke/downstroke	< 1 μS
Pulse rate	500
Resolution	± 0,01 Pulses/turn
Working temperature	-10° ÷ +70

Theoretical forces

Cyl. Ø	Theoretical force N (thrust with air supply 6 bar)
32	400
40	600
50	960
63	1600

Scheme of encoder

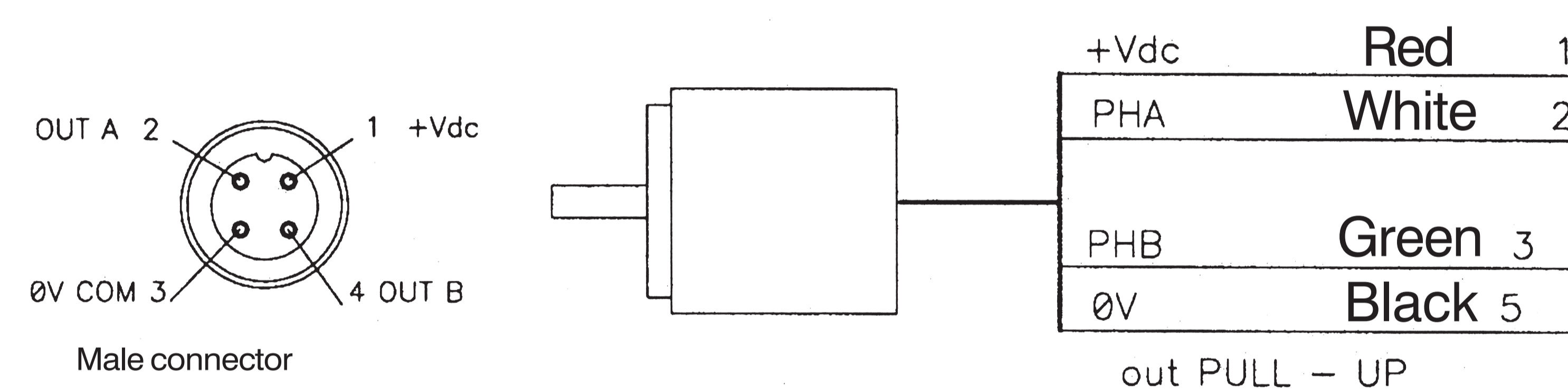

Overall dimensions

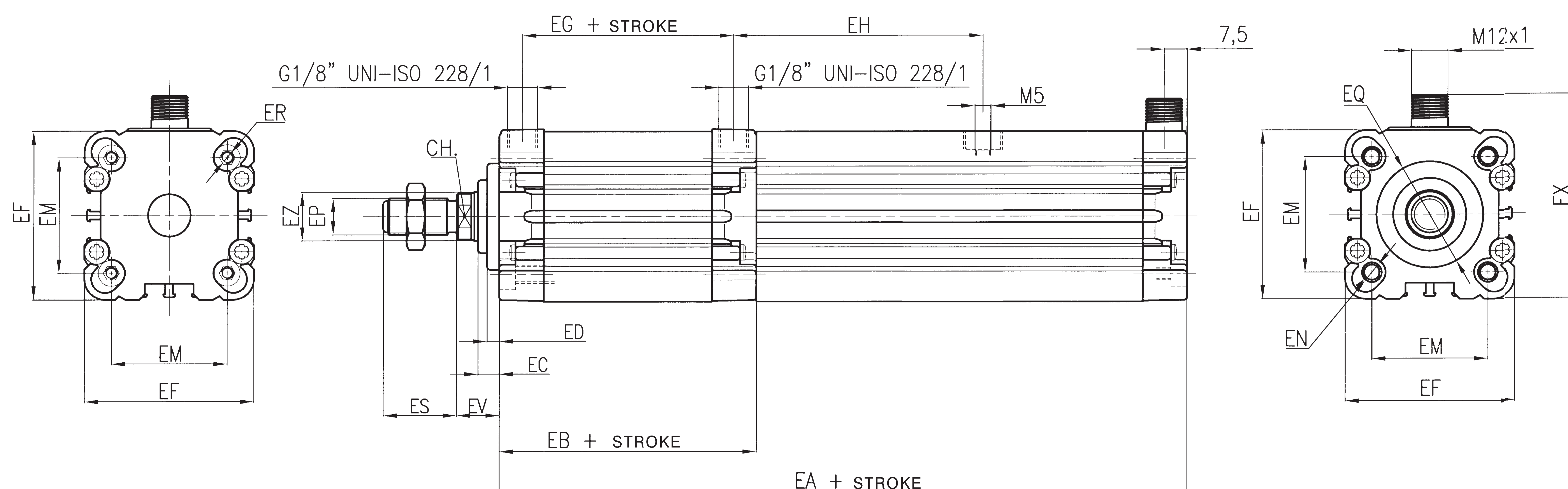

Ø	EA	EB	EC	ED	EF	EG	EH	EM	EN	EP	EQ	ER	ES	EV	EX	EZ	CH
32	217,5	84	7	4	46	68,5	55,5	32,5	M6 x 13	M10 x 1,25	ø 30	M4 x 10	22	14	57	12	10
40	225	89	7	4	56	74	58	38	M6 x 13	M12 x 1,25	ø 35	M4 x 10	24	14	67	16	13
50	234	94	10	5	66	79	63	46,5	M8 x 17,5	M16 x 1,25	ø 40	M6 x 10	32	18	77	20	17
63	253	114	10	5	79	99	63	56,5	M8 x 18	M16 x 1,25	ø 45	M6 x 10	32	18	90	20	17

Accessories

Mounting accessories: same as for cylinders STRONG series (Sect. Cylinders page 49-l)

Flush-mounted magnetic sensor DF-...series (Sect. Accessories page 2-V)

Strap for covering wires of magnetic sensor DHF-002100