

<b>Slide units for pneumatic cylinder suitable for:</b>				
<b>ISO 6431 - 6432 cylinders M series Ø 16 ÷ 25 K/KD series Ø 32 ÷ 100</b>	<b>Slide units for rodless cylinders S1 series Ø 25 ÷ 50</b>	<b>Short-stroke cylinders W series Ø 25 ÷ 100</b>	<b>Compact cylinders STRONG RS series Ø 32 ÷ 63</b>	<b>2-stage telescopic cylinders RT2 series Ø 32 ÷ 63</b>
<b>CONSTRUCTION CHARACTERISTICS</b>				
<p><b>Enlarged chromium-plated hollow guides provide robustness and reliability</b></p> <p><b>An economical solution thanks to the components used which ensure long life (7000 – 10000 km)</b></p> <p><b>Special metallic self-lubricating bearings, minimizing noise and abrasion</b></p> <p><b>Customized slide units available upon request</b></p> <p><b>High resistance to peak loads. Scraper bearings standard supplied for J10-.../J31-... series</b></p> <p><b>All models available with safety distance 25 mm for accident prevention according to EC rules EN 349</b></p>				
				
<b>TECHNICAL CHARACTERISTICS</b>				
Working pressure:				
<b>2 ÷ 10 bar</b>	<b>3 ÷ 10 bar</b>	<b>2 ÷ 10 bar</b>	<b>2 ÷ 10 bar</b>	<b>2 ÷ 10 bar</b>
Ambient temperature: <b>- 20°C ÷ 80°C</b>				
<b>SIZES</b>				
<b>16 ÷ 100</b>	<b>40 ÷ 80</b>	<b>25 ÷ 100</b>	<b>32 ÷ 63</b>	<b>32 ÷ 63</b>
<b>STANDARD STROKES (mm)</b>				
<b>25 ÷ 1000</b>	<b>up to 800 mm max</b>	<b>5 ÷ 75</b>	<b>15 ÷ 800</b>	<b>120 ÷ 1200</b>
<b>For min. and max. strokes refer to respective codification key.</b>				

High-Tech

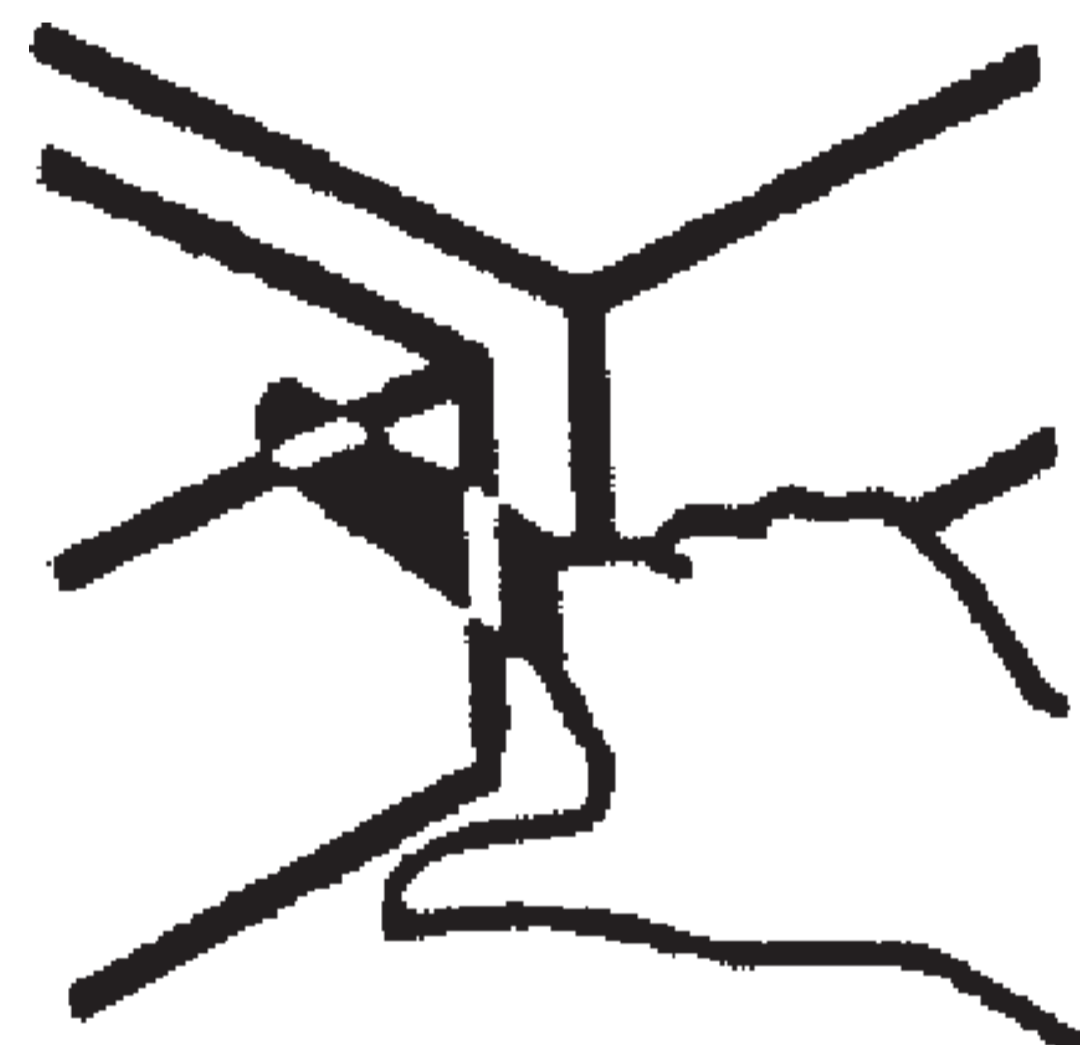

Slide units for...

Size slide unit	ISO 6431 - 6432 cylinders					Short-stroke cylinders			
	J10 M2=M3 (Nm)	J11 M2=M3 (Nm)	J12=J12B M2=M3 (Nm)	J14=J14B M2=M3 (Nm)	J16=J16B M2=M3 (Nm)	J51 M2=M3 (Nm)	J52 M2=M3 (Nm)	J53 M2=M3 (Nm)	J54 M2=M3 (Nm)
16	3,2	6,4	11	7,4	11	-	-	-	-
25	6	13,2	23,6	17,8	23,6	6	8,2	6	8,2
32	12,2	27,2	49	37,4	49	12,2	15	12,2	15
40	17,8	36,8	73,6	51	73,6	17,8	19,8	17,8	19,8
50	24,8	56	107,8	78	107,8	24,8	29,8	24,8	29,8
63	35,2	85,6	156,8	114	156,8	35,2	42,8	35,2	42,8
80	52	136	248	173,2	248	52	64,4	52	64,4
100	52	160	298	173,2	298	52	64,4	52	64,4

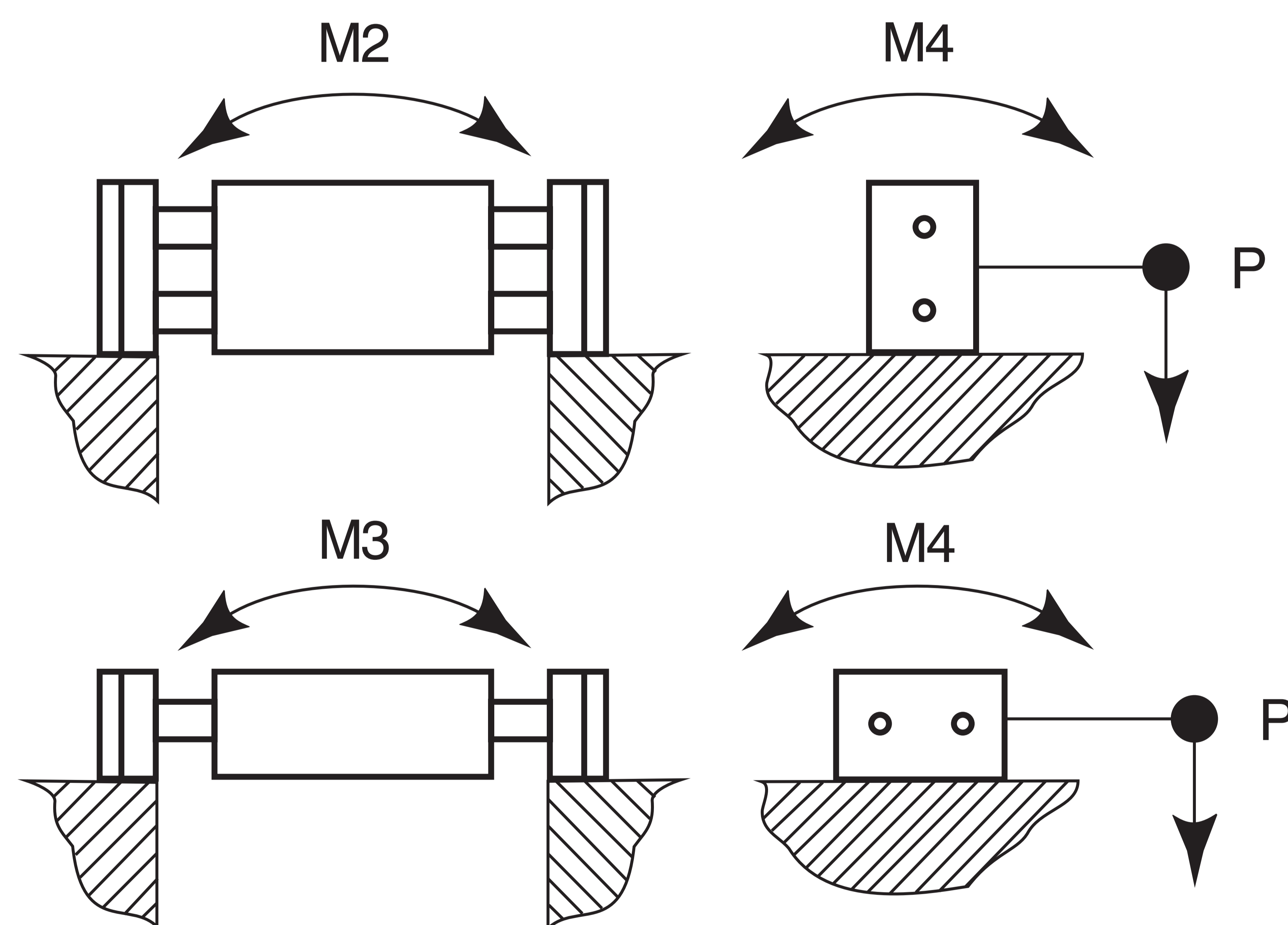

Slide units for...

Size slide unit	ISO 6431- 6432 cylinders			Short-stroke cylinders	M4 (Nm)
	J16=J16B M2/M3 (Nm)	J18 M2/M3 (Nm)	J19 M2/M3 (Nm)	J56 M2/M3 (Nm)	
16	12,8/8,8	10,4/4,4	12,8/8,8	-	9,4
25	28/19	22,2/8,6	28/19	22/7,6	20,4
32	55,6/38,8	45,2/17	55,6/38,8	42,6/15	39,8
40	80/59,4	58,5/22,6	80/59,4	57,4/19,8	53,8
50	121/75,2	92/33,4	121/75,2	90,4/29,8	85,6
63	173,6/122,6	135,2/52	173,6/122,6	130/42,4	123,4
80	270,2/196	204,2/84	270,2/196	196,6/64,4	186
100	318,6/245,6	230,8/109,2	318,6/245,6	213,2/64,4	203,2

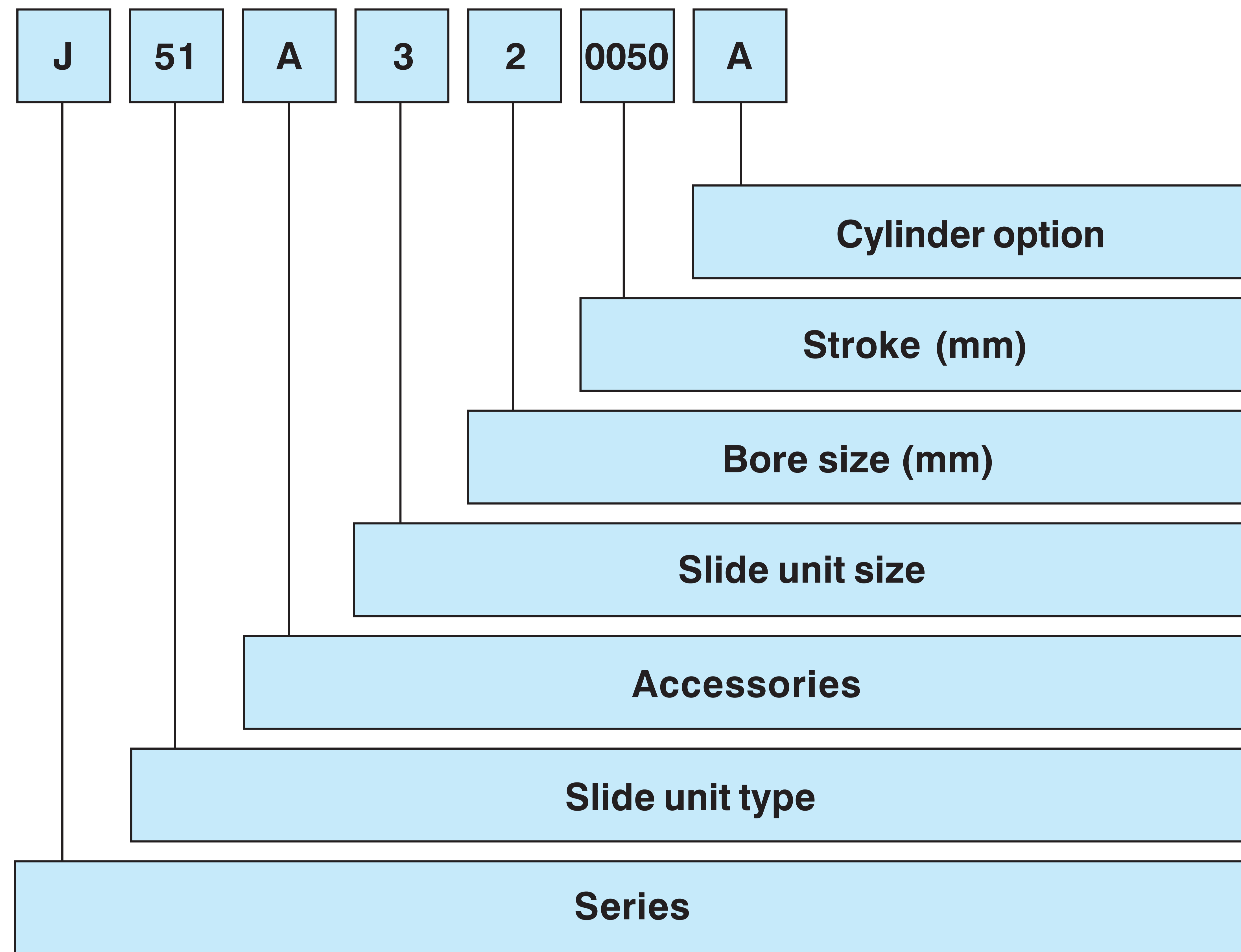

The slide units are supplied with safety distance (+ 25 mm) for accident prevention according to the European EN 349 specifications.

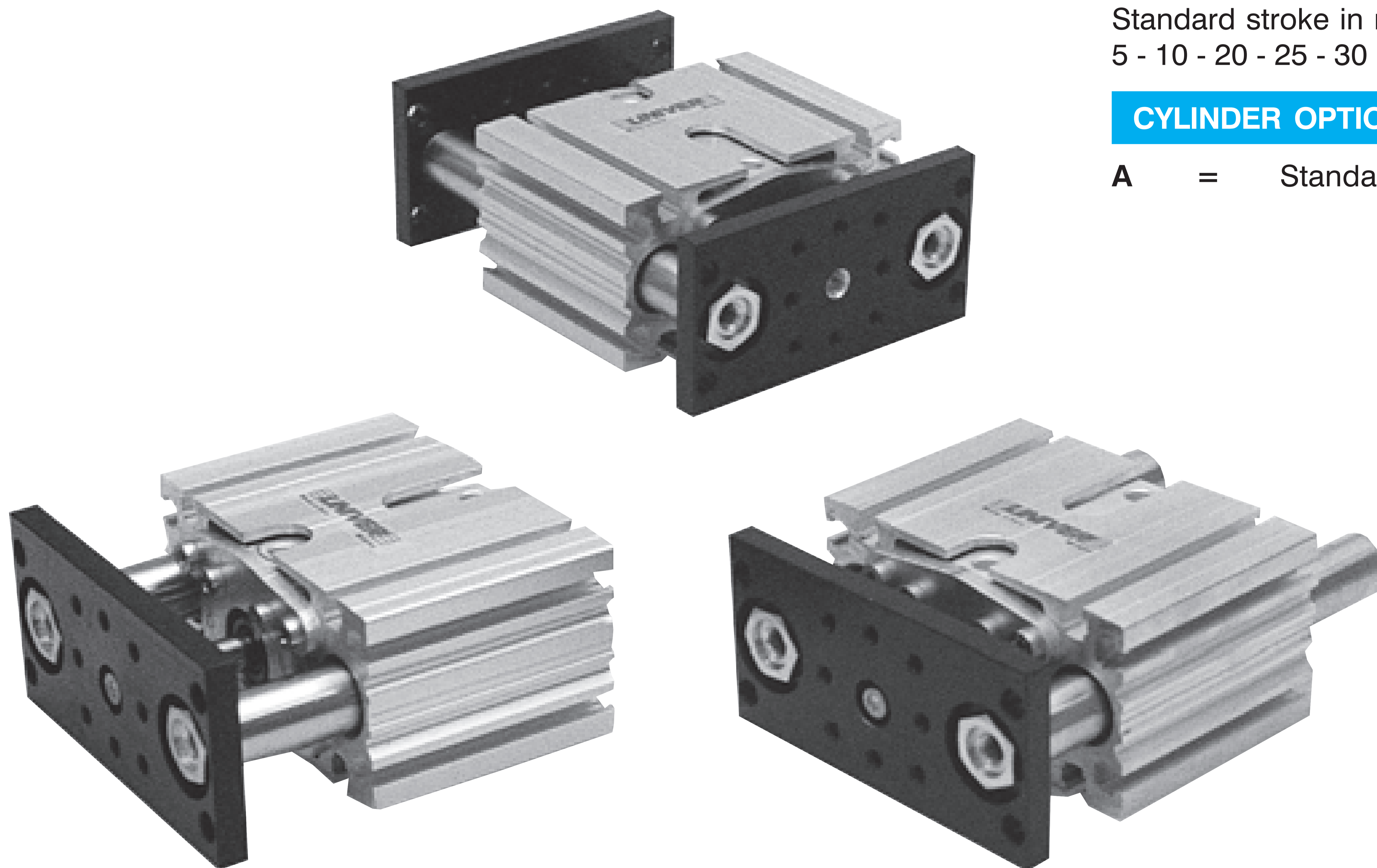

**SERIES**

J = Slide unit series

**SLIDE UNIT TYPE**

- 51 = Slide unit with protruding shafts (1 bearing).
- 52 = Slide unit with protruding shafts (2 bearings).
- 53 = Slide unit with fully protected cylinder (1 bearing).
- 54 = Slide unit with fully protected cylinder (2 bearings).
- 56 = Slide unit with fully protected cylinder (2 bearings + 2 plates).

**ACCESSORIES**

A = Scraper bearings

**SLIDE UNIT SIZE**

- 2 = 25 only for Ø 20 cylinder
- 3 = 32 only for Ø 25 cylinder
- 4 = 40 only for Ø 32 cylinder
- 5 = 50 only for Ø 40 cylinder
- 6 = 63 only for Ø 50 cylinder
- 7 = 80 only for Ø 63 cylinder
- 8 = 100 only for Ø 80 cylinder

**CYLINDER BORE SIZE**

- 1 = 20
- 2 = 25
- 3 = 32
- 4 = 40
- 5 = 50
- 6 = 63
- 7 = 80

**SLIDE UNIT STROKE**

Standard stroke in mm  
5 - 10 - 20 - 25 - 30 - 50 - 75

**CYLINDER OPTION**

A = Standard cylinder

**NOTE:** slide units are supplied complete with a non-magnetic cylinder. Magnetic version require a DKJ Series reed switches mounting rail which is to be ordered separately (see section accessories page 6)

**J51 . . . . .**, 1 bearing with protruding shafts  
**J52 . . . . .**, 2 bearings with protruding shafts

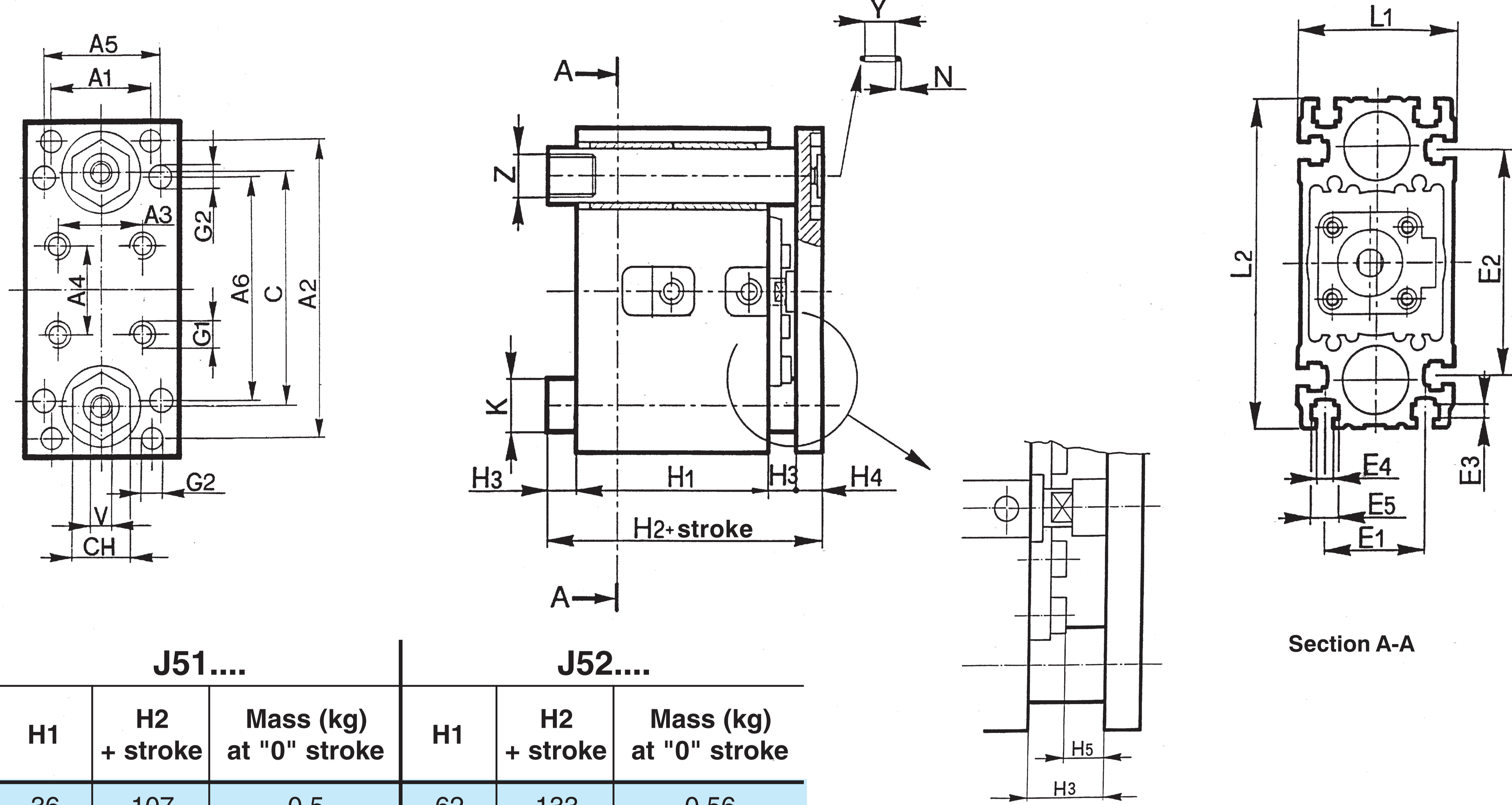

Size of slide unit	Cyl. Ø	J51....			J52....		
		H1	H2 + stroke	Mass (kg) at "0" stroke	H1	H2 + stroke	Mass (kg) at "0" stroke
25	20	36	107	0,5	62	133	0,56
32	25	42	120	0,875	74	152	0,955
40	32	45	125	1,225	80	160	1,34
50	40	50	132	2,17	90	172	2,36
63*	50	55	139	3,2	100	184	3,46
80*	63	62	152	5,04	114	204	6,125
100*	80	62	152	5,92	114	204	7,040

**J53 . . . . .**, 1 bearing with fully protected cylinder  
**J54 . . . . .**, 2 bearings with fully protected cylinder

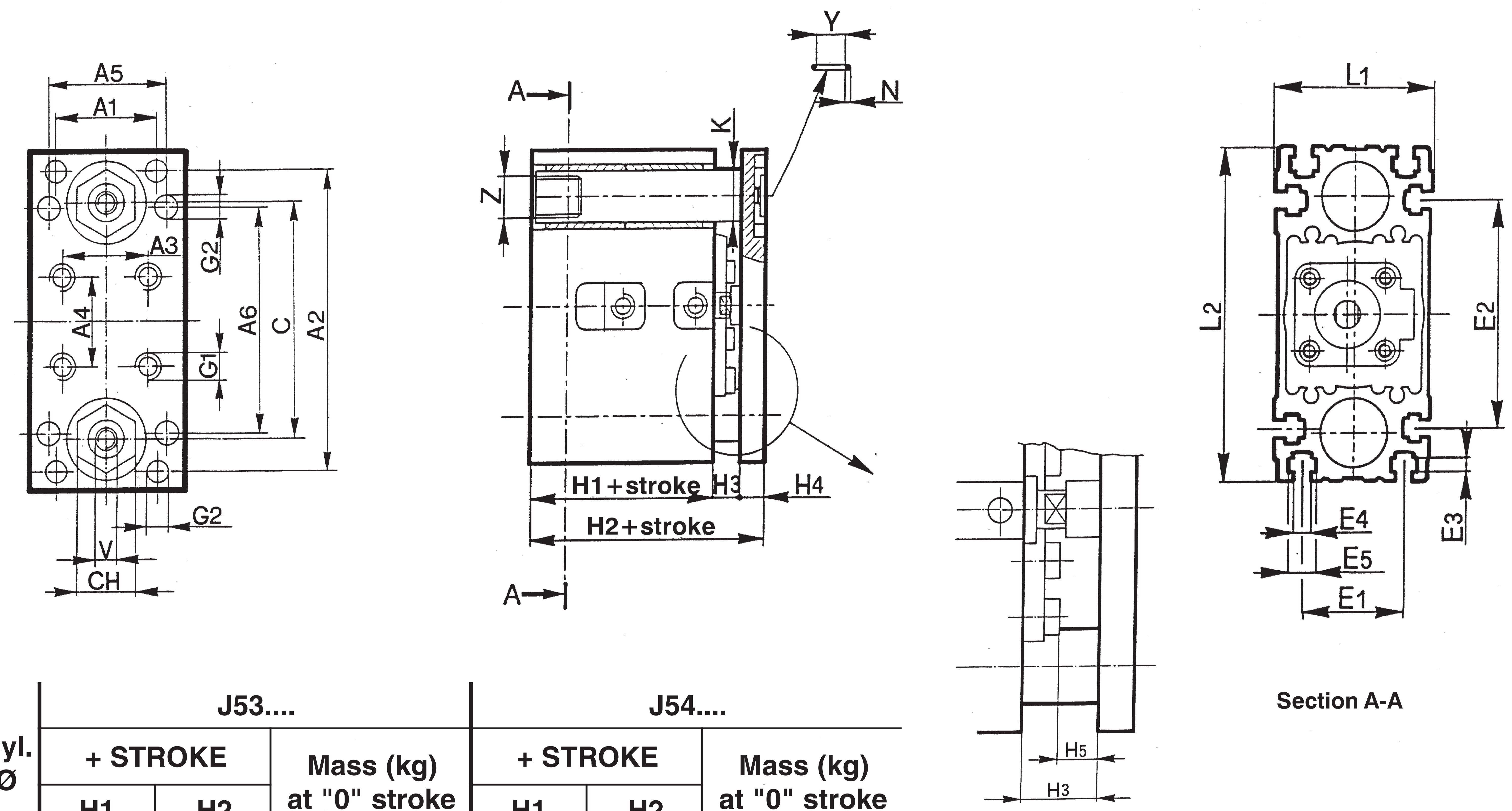

Size of slide unit	Cyl. Ø	J53....			J54....		
		+ STROKE		Mass (kg) at "0" stroke	+ STROKE		Mass (kg) at "0" stroke
		H1	H2		H1	H2	
25	20	36	75,5	0,475	62	101,5	0,54
32	25	42	86	0,845	74	118	0,925
40	32	45	90	1,18	80	125	1,3
50	40	50	96	2,1	90	136	2,3
63*	50	55	103	3,13	100	148	3,39
80*	63	62	113	4,99	114	165	6,02
100*	80	62	113	5,82	114	165	6,93

\*For dimensions not indicated and note regarding sizes 63 - 80 - 100 refer to page 49.

**J56 . . . . , 2 bearings and 2 plates**

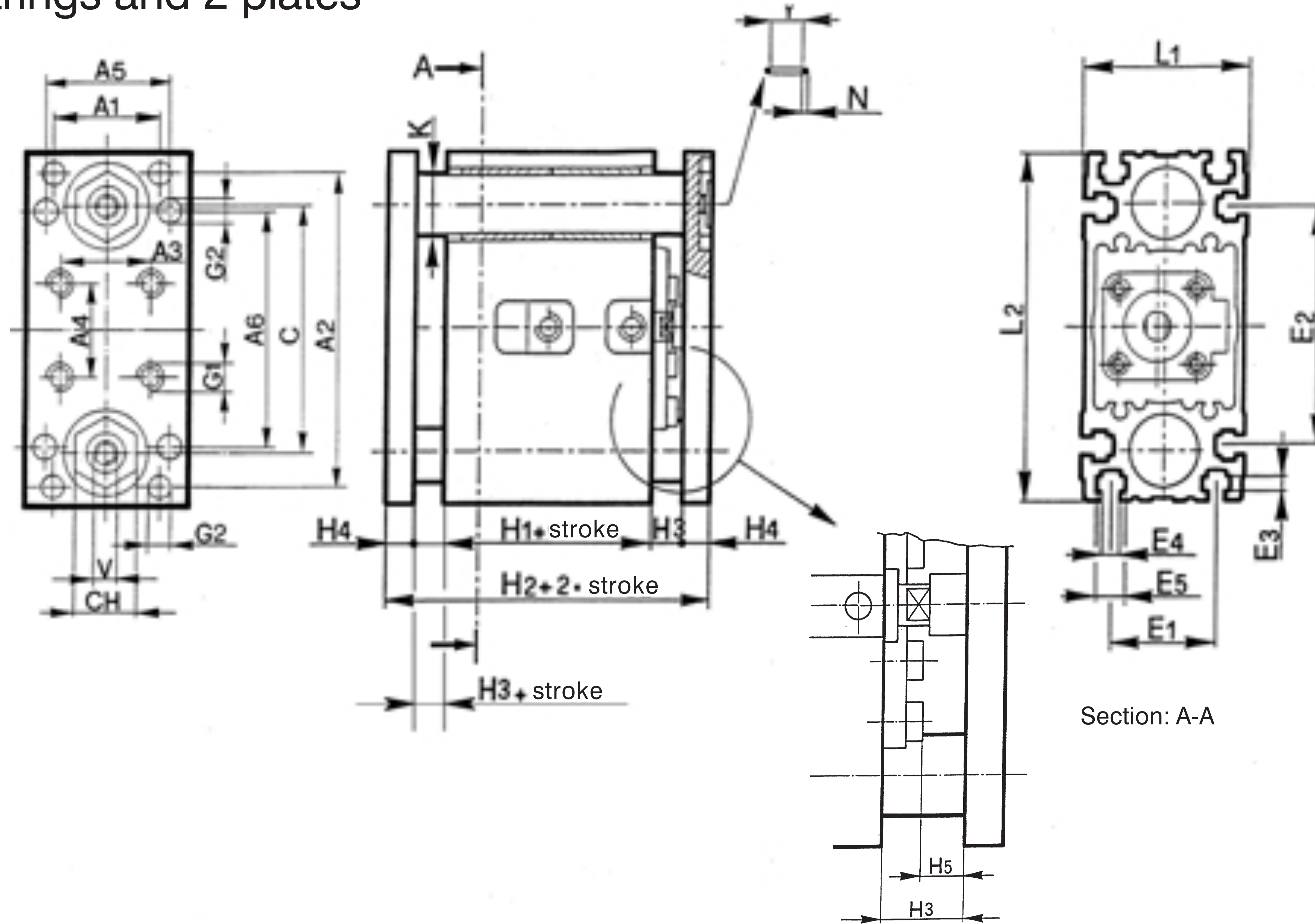

Size of slide unit	Cyl. Ø	J56....		
		+ STROKE	+ 2 • STROKE	Mass (kg) at "0" stroke
		H1	H2	
25	20	62	141	0,63
32	25	74	162	1,04
40	32	80	170	1,48
50	40	90	182	2,54
63*	50	100	196	3,68
80*	63	114	216	6,34
100*	80	114	216	7,19

**Common dimensions of slide units with short stroke cylinder**

Size	Cyl. Ø	A1	A2	A3	A4	A5	A6	C	CH	E1	E2	E3	E4	E5	G1	G2*	H3	H4	H5	K	L1	L2
25	20	32	85	27	27	36	62	69	14	32	62	5	5,4	8,4	M5	Ø6H8	31,5	8	25	16	47	96
32	25	38	108	32,5	32,5	46	82	85	22	38	82	5	6,4	10,4	M6	Ø6H8	34	10	25	20	58	120
40	32	42	118	38	38	54	90	95	22	42	90	5	6,4	10,4	M6	Ø8H8	35	10	25	22	66	130
50	40	48,1	140	46,5	46,5	69	110	115	27	48	110	6,5	8,4	13,4	M8	Ø8H8	36	10	25	25	84	155
63	50	56	157,5	56,5	56,5	79,5	120	130	30	56	120	7,5	10,5	17,5	M8	Ø8H8	36	12	25	28	98	176
80	63	65	178	72	72	95	142	150	32	65	142	8,5	10,5	18	M10	Ø8H8	39	12	25	32	117	200
100	80	72	194	89	89	113	156	164	32	72	156	8,5	10,5	18	M10	Ø8H8	39	12	25	32	133	214

\* For use with locking pin tolerance m 6.

Size	Cyl. Ø	N	V	Y	Z	Mass (kg) at "0" stroke	Mass increase (g) per mm stroke		
						Cylinder	Shafts	Cylinder	Slide unit
25	20	1,78	M5	5,28	M12	0,155	1,92	3,25	4
32	25	2,62	G 1/8	10,78	M16x1,5	0,292	2,51	4,45	6
40	32	2,62	G 1/8	10,78	M18x1,5	0,43	2,81	5,3	7
50	40	2,62	G 1/8	10,78	M20x1,5	0,446	3,71	6,4	11
63	50	2,62	G 1/8	10,78	M22x1,5	0,772	4,7	7,9	13,6
80	63	2,62	G 1/8	10,78	M27x2	1,275	5,52	14,5	18
100	80	2,62	G 1/8	10,78	M27x2	1,92	5,52	19,7	20

**N.B.:** on the 4 sides the plates for sizes 63 - 80 - 100 have chamfers as indicated in the following table:

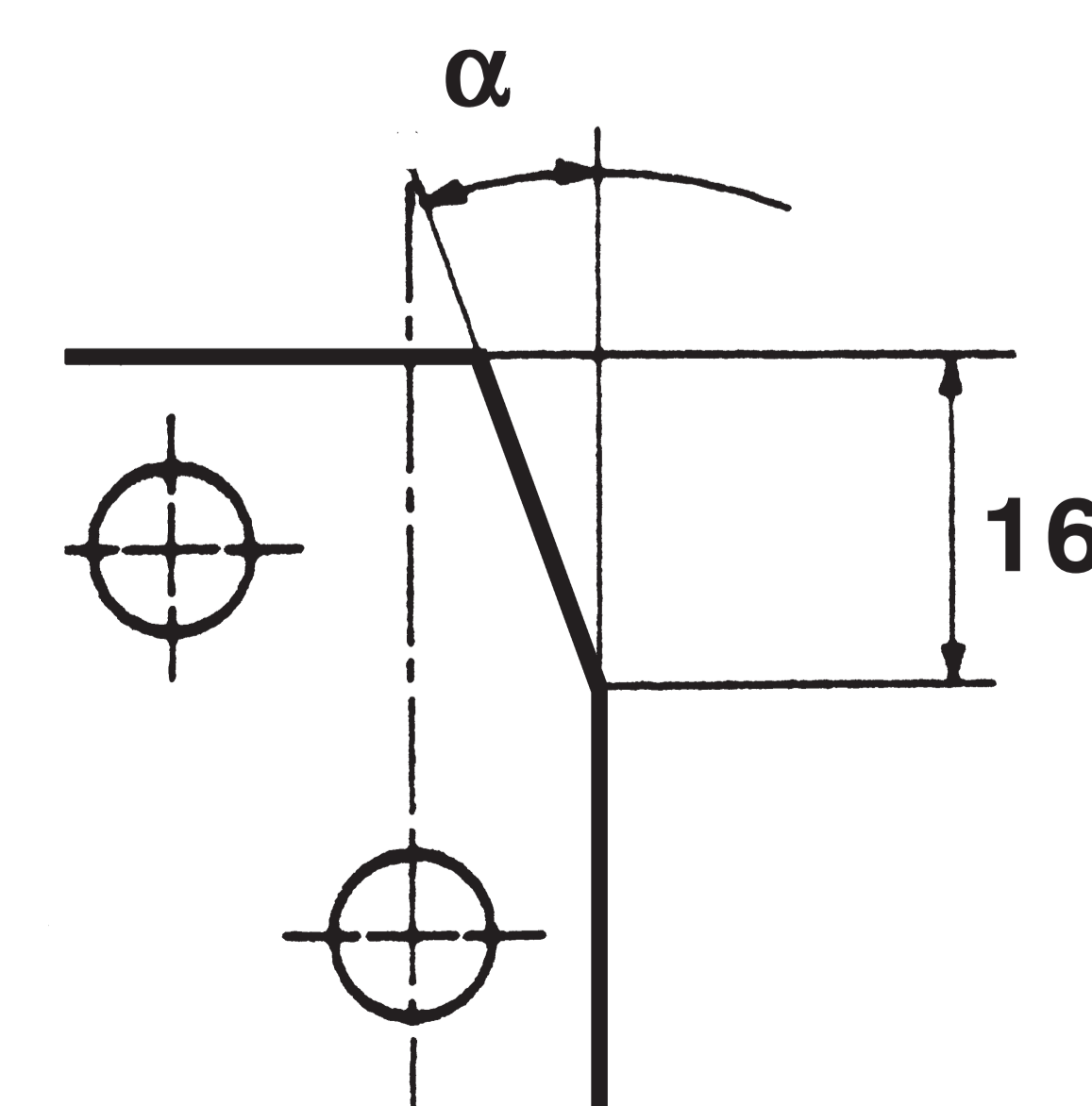

Size	α
63	20°
80	35°
100	40°

**Aluminium foot brackets**

SIZE	A	B	C	D	E	F	G	H	L	Part number
16	52	30	10	26	4	9	20	Ø 4,5	43	JF-13016
25	70	30	10	26	4	9	32	Ø 5,5	57	JF-13025
32	85	35	10	30	5	10	38	Ø 6,5	72	JF-13032
40	92	35	10	30	5	10	42	Ø 6,5	79	JF-13040
50	11	40	15	35	5	12,5	48	Ø 8,5	102	JF-13050
63	13	45	15	40	5	15	56	Ø 10,5	112	JF-13063
80	16	45	15	40	5	15	65	Ø 10,5	135	JF-13080
100	17	45	15	40	5	15	72	Ø 10,5	151	JF-13100

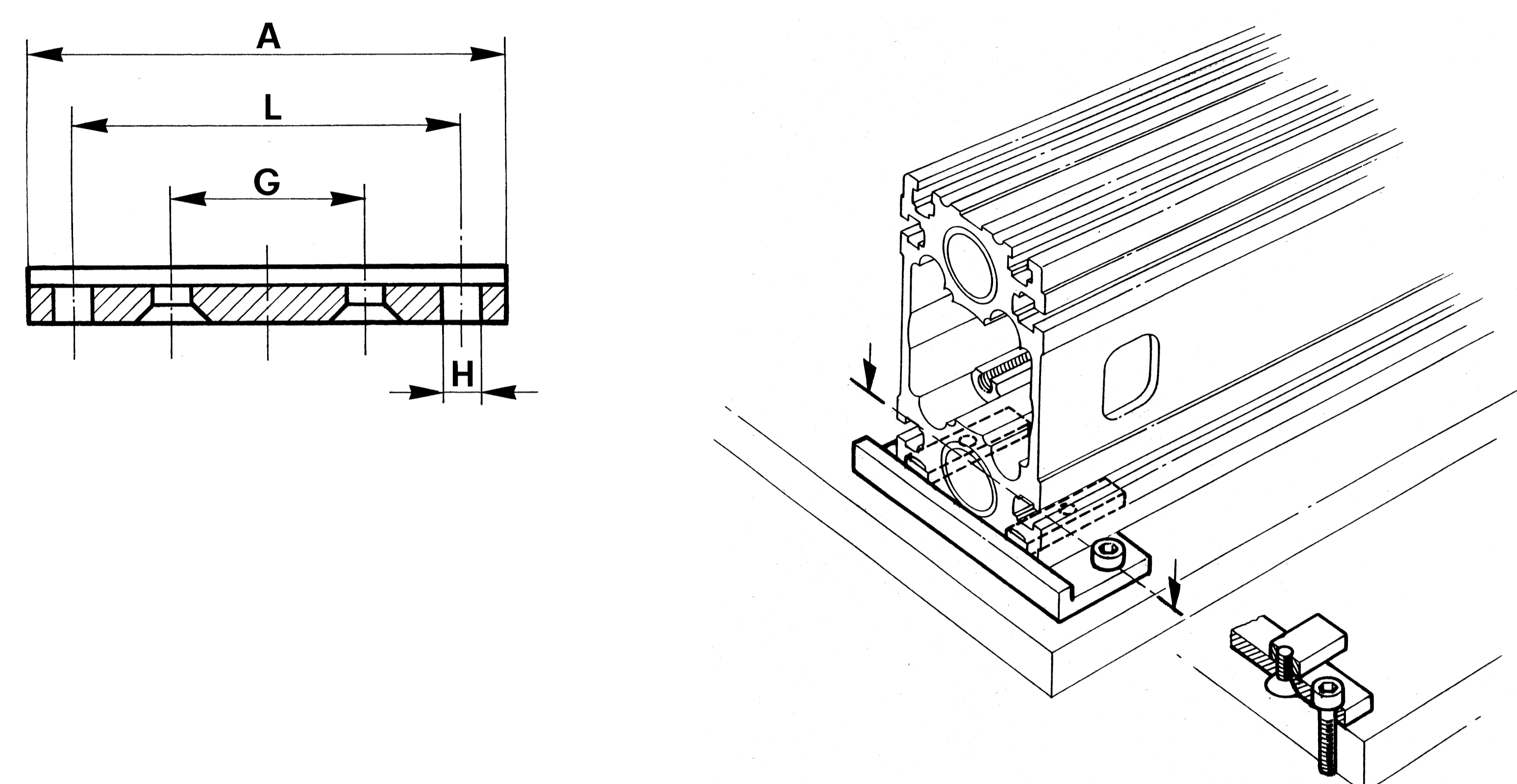

Package consists of 2 pcs. including mounting accessories.

**Fixing plates in steel**

SIZE	A	B	C	D	E	F	Part number
16	3	7	7,5	15	30	M4	JF-42016
25	4	8	10	15	35	M5	JF-42025
32 - 40	4	10	10	20	40	M6	JF-42040
50	6	13	10	30	50	M8	JF-42050
63	6	16	12,5	35	60	M10	JF-42063
80 - 100	8	16	15	40	70	M10	JF-42100

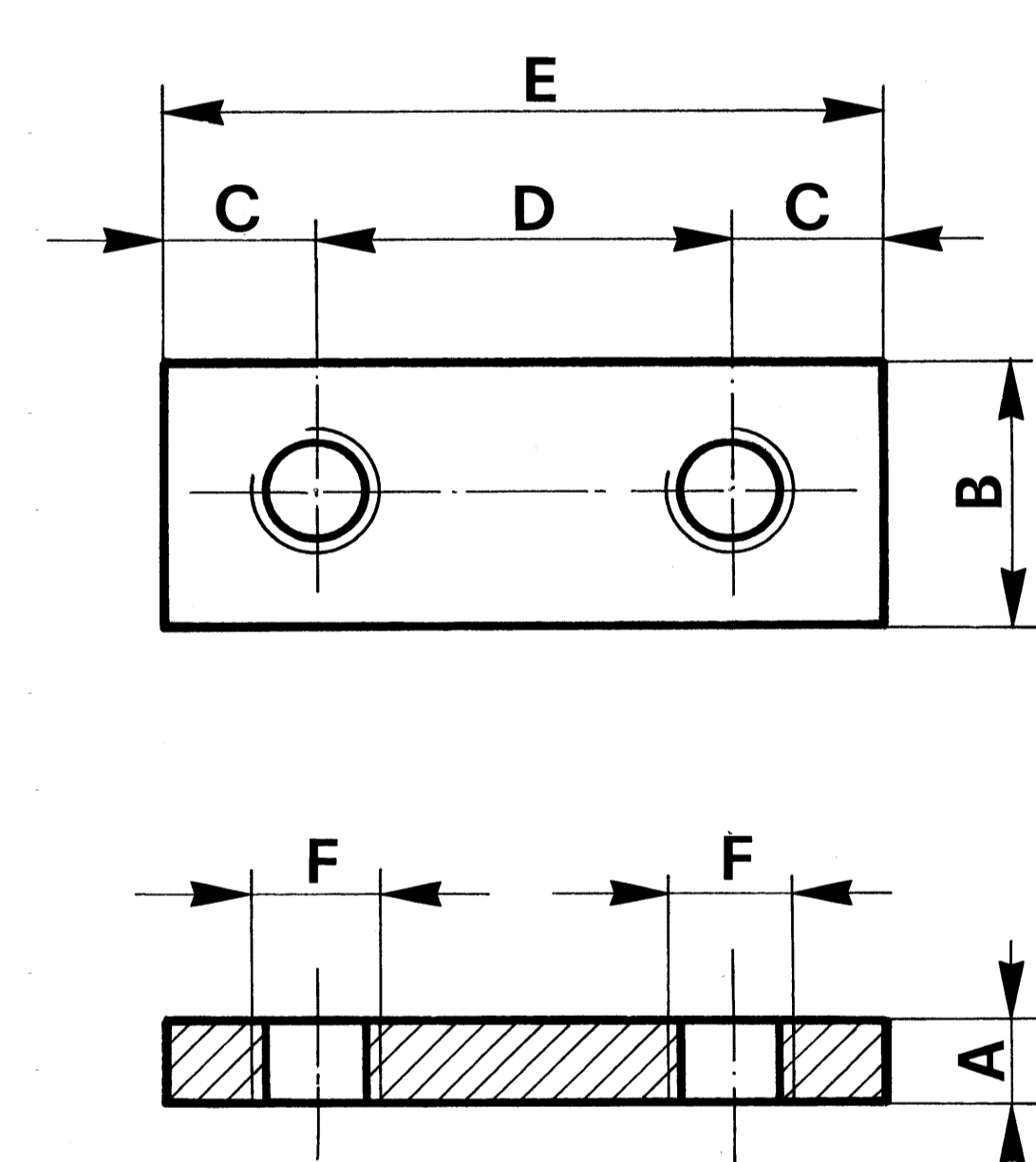

Package consists of 2 pcs. including mounting accessories.

**Shaft support for slide units  
J10/J11/J12 Series**

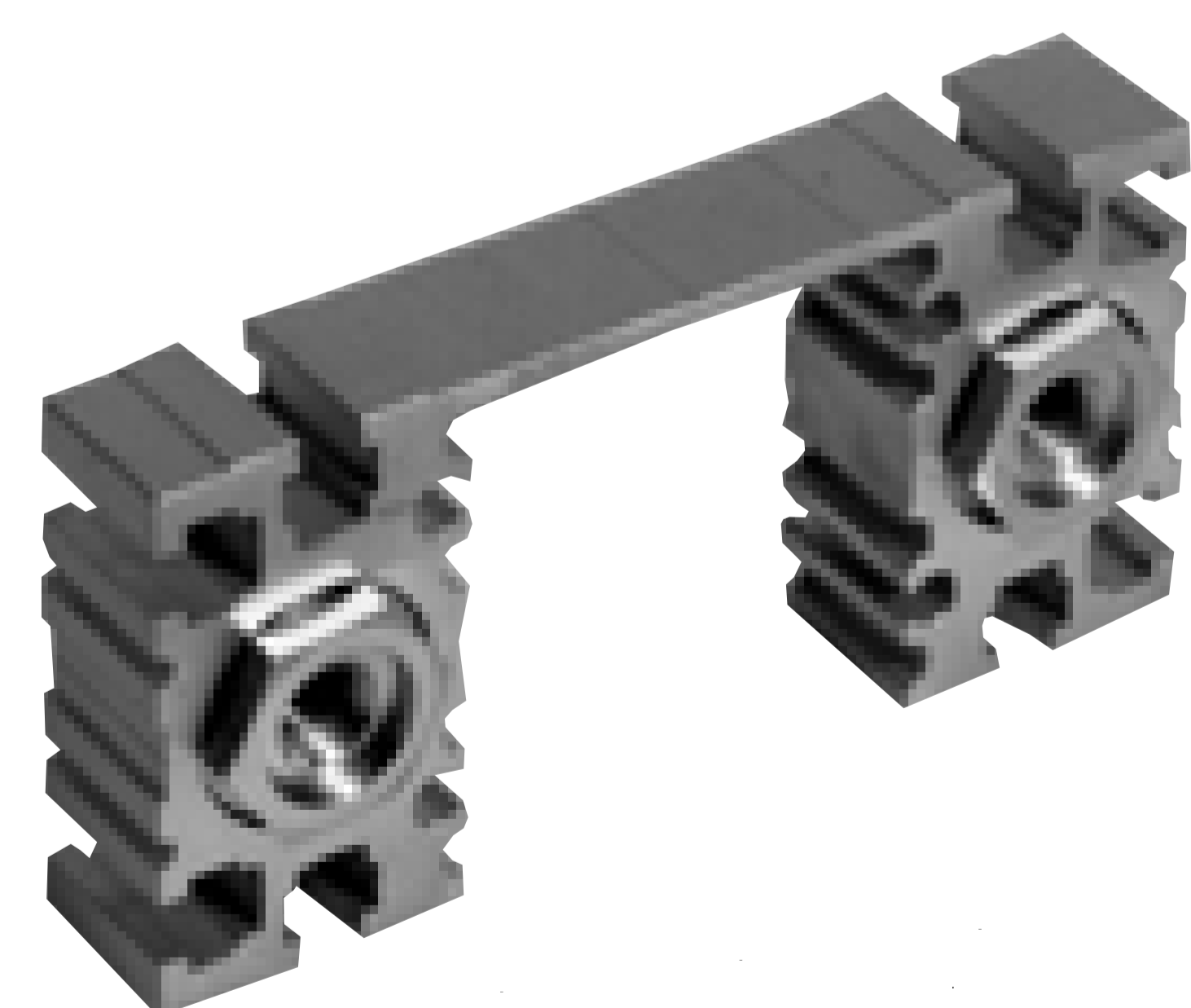

SIZE	Part number
16	JF-601016
25	JF-601025
32	JF-601032
40	JF-601040
50	JF-601050
63	JF-601063
80	JF-601080
100	JF-601100

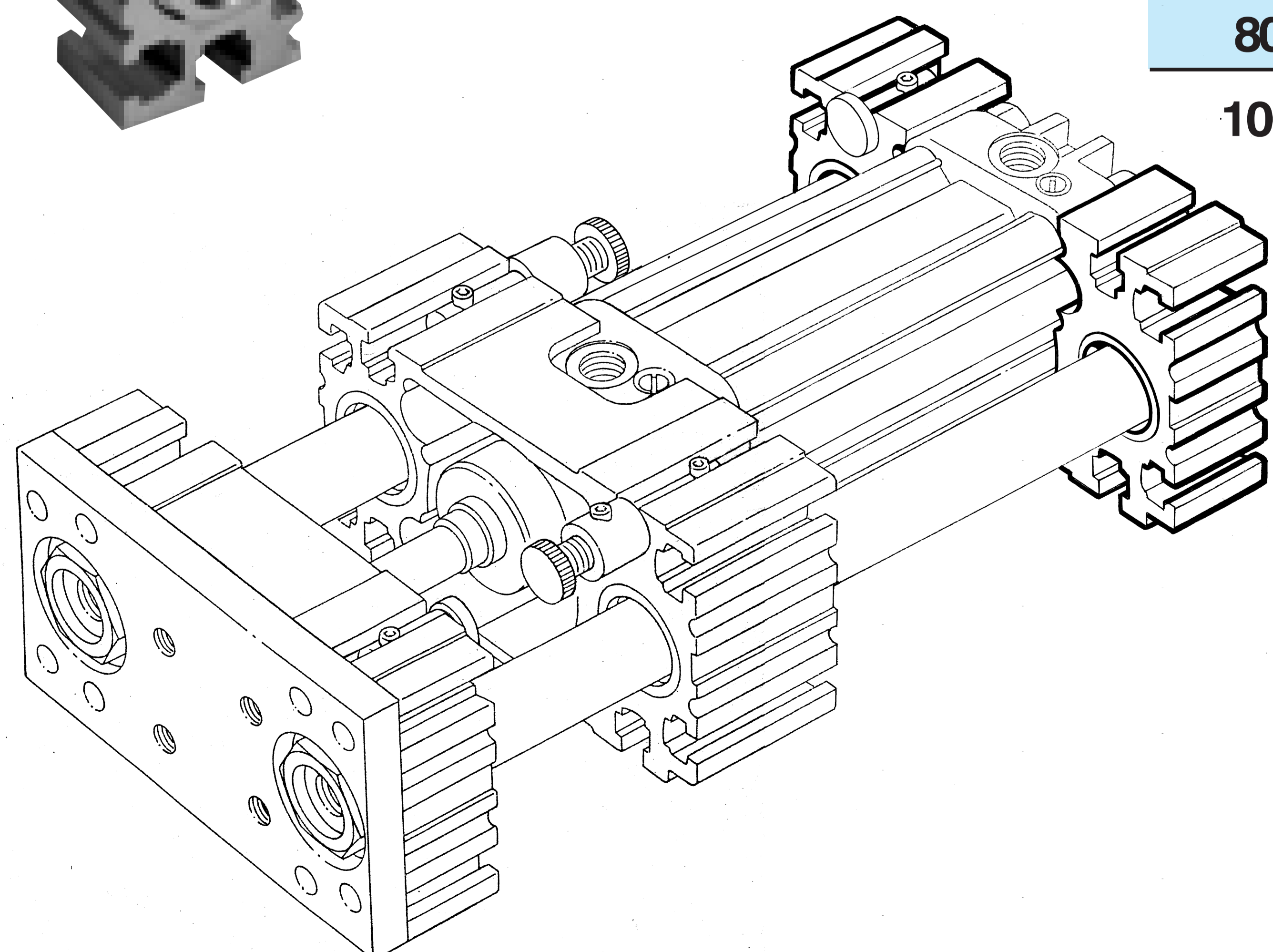

SIZE	A	B	C	D	E	F	G	H	Part number
16	50	30	10	26	3	9	31	Ø 4,5	JF-14016
25	55	30	10	26	3	9	34	Ø 5,5	JF-14025
32	60	35	10	30	4	10	38	Ø 6,5	JF-14032
40	65	35	10	30	4	10	40	Ø 6,5	JF-14040
50	70	40	15	35	4	12,5	45	Ø 8,5	JF-14050
63	85	45	15	40	4	15	56	Ø 10,5	JF-14063
80 - 100	90	45	15	40	4	15	58	Ø 10,5	JF-14100

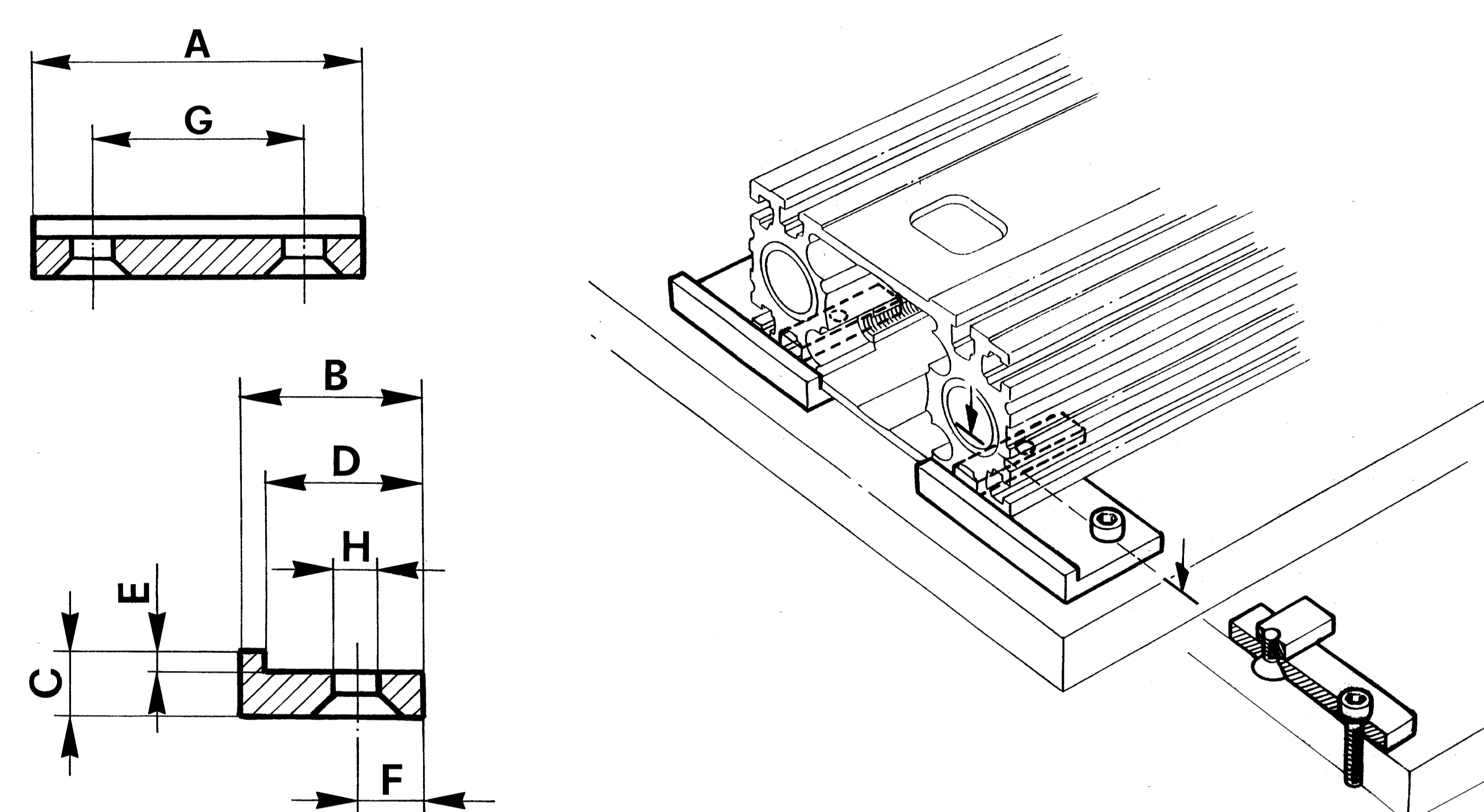

Package consists of 4 pcs. including mounting accessories.

SIZE	A	B	C	D	Part number
16	3	7	16	M4	JF-43016
25	4	8	16	M5	JF-43025
32 - 40	4	10	18	M6	JF-43040
50	6	13	18	M8	JF-43050
63	6	16	22	M10	JF-43063
80 - 100	8	16	25	M10	JF-43100

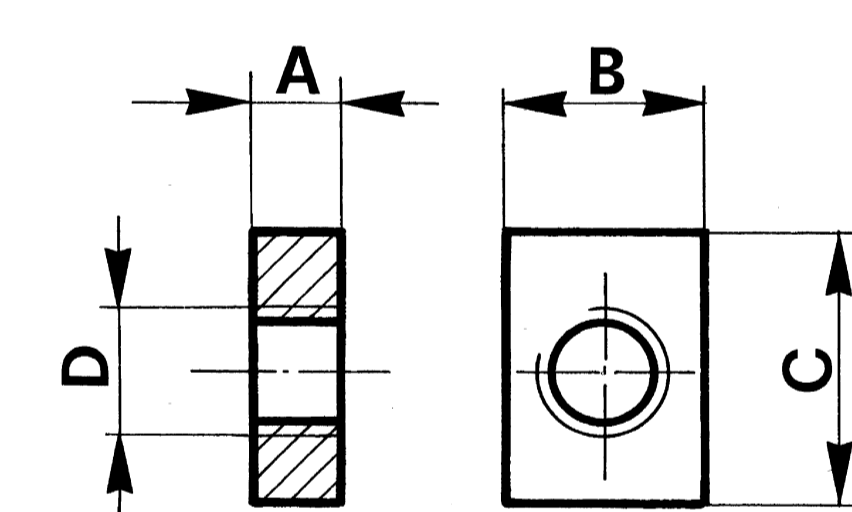

Package consists of 2 pcs. including mounting accessories.

**Scraper bearings**

SIZE	Ø A	Part number
16	12	JF-19016
25	16	JF-19025
32	20	JF-19032
40	22	JF-19040
50	25	JF-19050
63	28	JF-19063
80 - 100	32	JF-19100

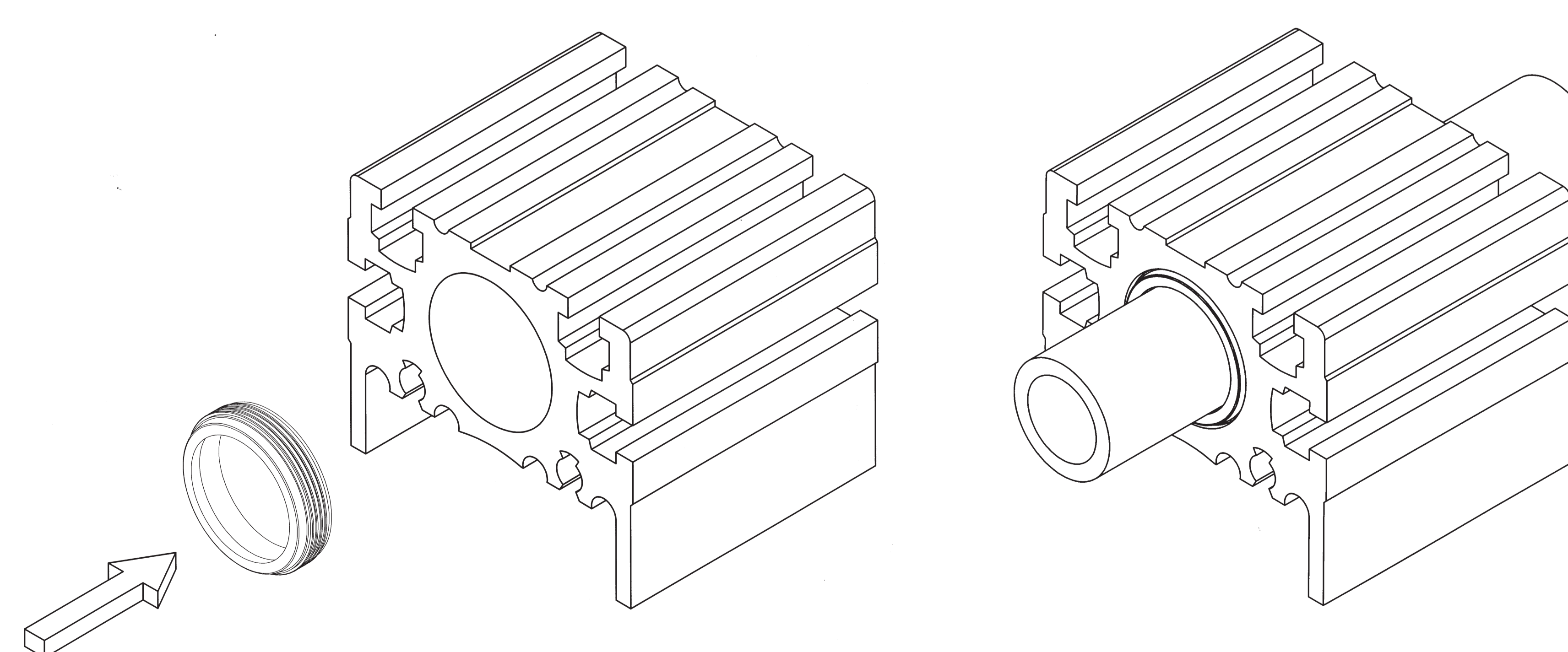
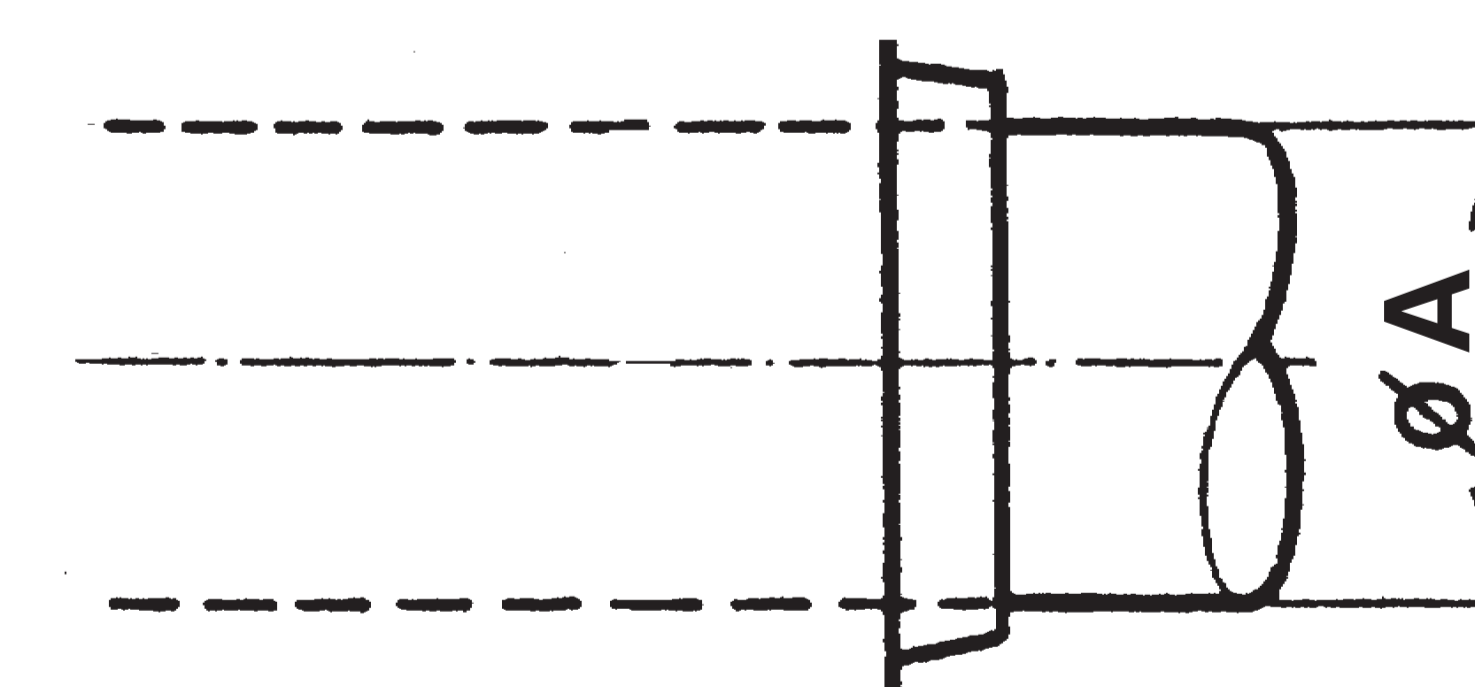

Package comprises 4 pcs.