

CHARACTERISTICS

Ambient temperature	-20 ÷ 80 °C
Fluid	filtered air, with or without lubrication
Working pressure	1,5 ÷ 10 bar

End-caps	anodized aluminium
Barrel	anodized aluminium
Piston	aluminium
Guide slide	technopolymer
Piston rod	stainless steel (Ø18-25), chromium-plated steel (Ø32÷80)
Piston seal	NBR
Guide bush for piston rod	standard supplied
Piston rod scraper seals	polyurethane
Cushionings	pneumatic adjustable (standard supplied)
Magnet	standard supplied



CODIFICATION KEY

O	V	2	0	0	0	3	2	0	0	5	0
1	2	3	4		5						

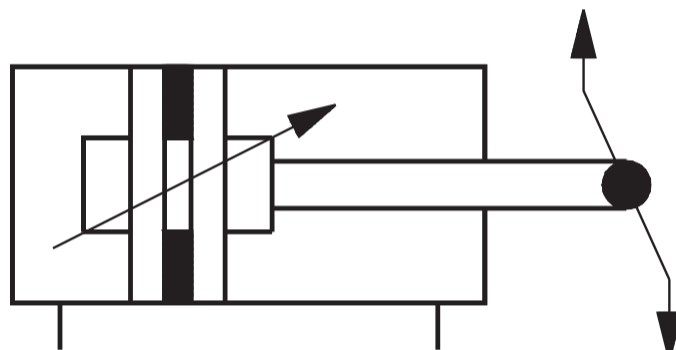
1 Series OV = Ø 18÷80 mm - Oval Cylinders 	2 Type 1 = Stainless steel female piston rod (Ø18÷80) 2 = Chromium-plated steel female piston rod (Ø32÷80) 3 = Stainless steel male piston rod (Ø18÷80) 4 = Chromium-plated steel male piston rod (Ø32÷80)	3 Version 00 = D.A. Standard version 01 = D.A. Through piston rod 02 = D.A. Hollow through piston rod
--------------------------------------------------------------------------------------------------------------------------------------------	-------------------------------------------------------------------------------------------------------------------------------------------------------------------------------------------------------------------------------	-----------------------------------------------------------------------------------------------------------------------

D.A. = Double acting

4 Bore (mm) 018 = Ø18 025 = Ø25 032 = Ø32 040 = Ø40 050 = Ø50 063 = Ø63 080 = Ø80	5 Stroke (mm) 0010 - 0025 - 0040 - 0050 - 0080 - 0100 - 0125 - 0160 - 0200 (Ø18-25) 0010 - 0025 - 0040 - 0050 - 0080 - 0100 - 0125 - 0160 - 0200 - 0250 - 0320 (Ø 32÷80)
---------------------------------------------------------------------------------------------------------------	---------------------------------------------------------------------------------------------------------------------------------------------------------------------------------------

Theoretical forces (N) developed at working pressure (bar)

Ø	Working pressure					Working pressure					Cushioning length
	bar					bar					
	Thrust					Traction					
	2	4	6	8	10	2	4	6	8	10	
18	54	108	162	216	270	41	82	122	163	204	8
25	98	196	295	393	491	82	165	247	330	412	10
32	161	322	483	643	804	138	276	415	553	691	10
40	251	502	754	1005	1256	221	422	633	844	1055	14
50	393	785	1178	1570	1963	330	660	990	1320	1650	Front 11/Back 14
63	623	1246	1870	2493	3116	560	1120	1682	2240	2800	Front 11/Back 14
80	1005	2010	3015	4019	5024	942	1884	2826	3770	4711	Front 20/Back 27

FIXING ELEMENTS AND ACCESSORIES

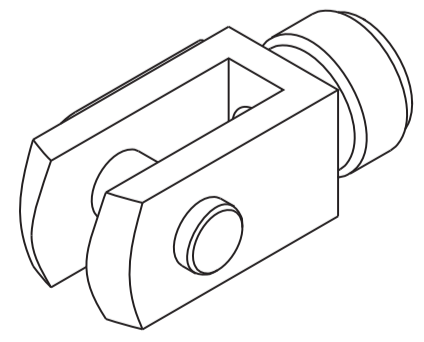
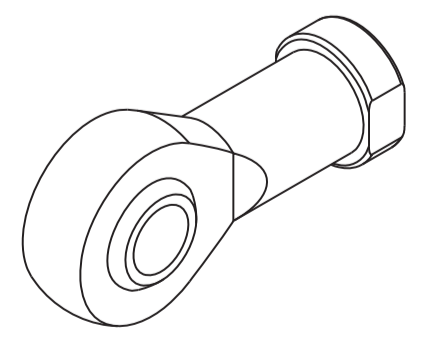
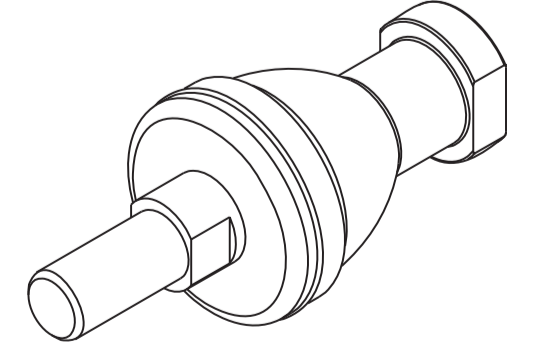
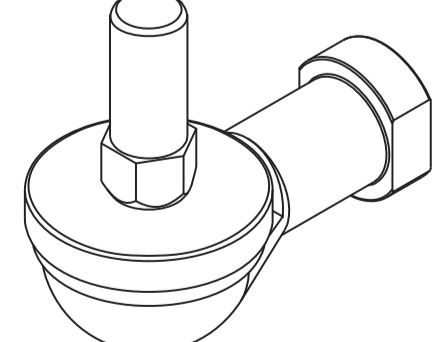
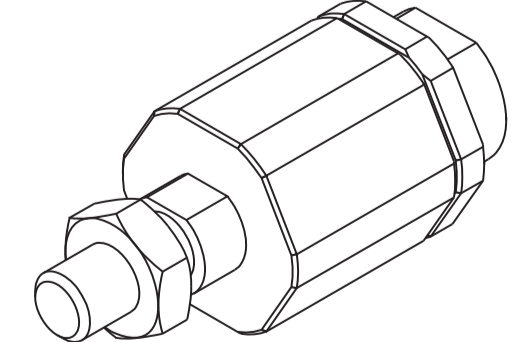
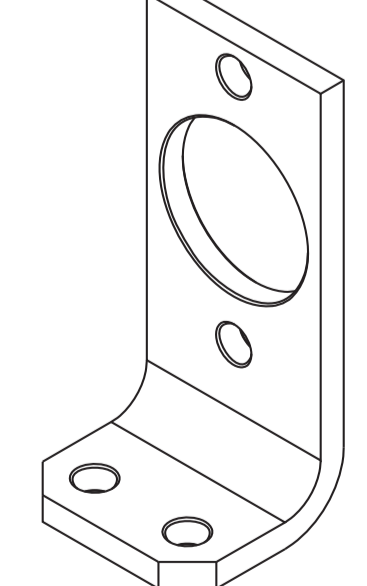
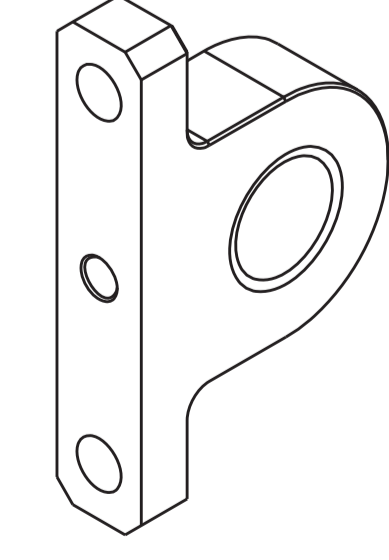
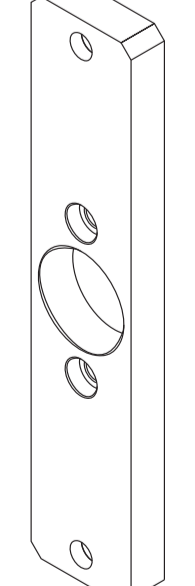
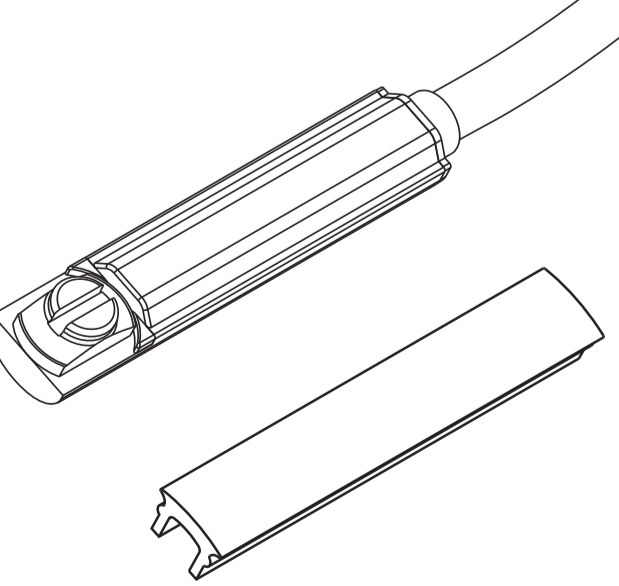
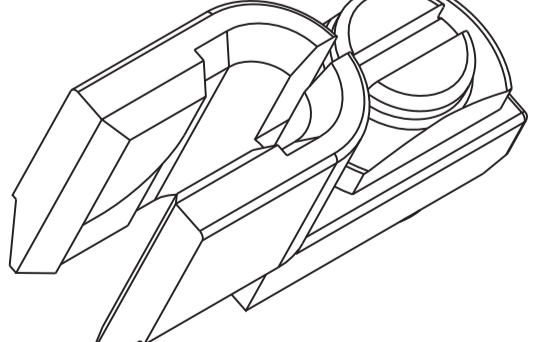
Ø	Female fork with clips	Articulated self-lubricating fork	Fork with axially mounted articulated pin	Fork with angle mounted articulated pin	Floating joint	Angle bracket	Male hinge	Flange	DF sensor and DHF covering strip	Cable clamping for DF sensor
18										
25	KF-15020	KF-17020	KF-22020	KF-23020	KF-24020	OVF-13018	OVF-11018	OVF-12018		
32	KF-15032	KF-17032	KF-22032	KF-23032	KF-24032	OVF-13025	OVF-11025	OVF-12025		
40	KF-15032	KF-17032	KF-22032	KF-23032	KF-24032	OVF-13032	OVF-11032	OVF-12032		
50	KF-15040	KF-17040	KF-22040	KF-23040	KF-24040	OVF-13040	OVF-11040	OVF-12040		
63	KF-15050	KF-17050	KF-22050	KF-23050	KF-24050	OVF-13050	OVF-11050	OVF-12050		
80	KF-15050	KF-17050	KF-22050	KF-23050	KF-24050	OVF-13063	OVF-11063	OVF-12063		
						OVF-13080	OVF-11080	OVF-12080	DF DHF-0020100	DF-001