

QML35 EZ-COMM

DESIGN FEATURES

- Programmable commutation
- Single-ended outputs
- Bearingless modular design
- Low profile assembled height of 0.43"
- Resolutions up to 5000 lines per revolution
- 4, 6, 8, 10 or 14 pole commutation³
- Easy lock-n-twist assembly feature
- Through bore sizes up to 0.375" diameter
- Up to 675 kHz frequency response
- High noise immunity
- RoHS construction
- Hub to shaft uses two #3-48 set screws
- Hermetically sealed LED
- Multiple mounting options including resolver size 15



Recommended Connector: BERG (FCI) P/N 90312-008 LF

The Quantum Devices EZ-Comm system is the fastest and most economical way to align an optical encoder's commutation channels to a motor. EZ-Comm was designed to reduce assembly cost for high volume manufacturing. By eliminating multiple steps from the typical timing of an encoder and motor, EZ-Comm saves manufacturing time and reduces assembly cost. EZ-Comm is integrated into the high performance, low profile modular design of the QML35. QML35 EZ-Comm is ideal for high volume OEM applications and priced competitively for all sizes of motion control projects. As simple as a push of a button, EZ-Comm is the newest and simplest way to commutate your BLDC motors.



Configuration Options:

Resolution	Commutation	Voltage	Cover	Bore Size	Mounting	Index	Hardware
Please refer to available line count and pole combinations below	Please refer to available line count and pole combinations below	D = 5V ± 5% with EZ-Comm	A = Hole in Cover B = Closed Cover (shaft < 0.512") C = Closed Cover (shaft < 0.450")	C = 5 mm D = 6 mm E = 8 mm K = 0.1875" L = 0.250" M = 0.3125" N = 0.375"	A = 1.280" B = 1.812"	A = 90° A & B High B = 90° A & B Low	Please refer to hardware options on page 7

Available Line Count and Pole Combinations

Poles	Line Count
4	500, 512, 1000, 1024, 2000, 2048, 2500
6	500, 512, 1000, 1024, 2000, 2048, 2500, 4000, 4096
8	500, 512, 1000, 1024, 2000, 2048, 2500, 4000, 4096, 5000
10	500, 512, 1000, 1024, 2000, 2048, 2500, 4000, 4096, 5000
14	2048

Note:

- 1.) 4 poles has four states per revolution (2 pole pair), or two 360° electrical cycles per revolution
- 2.) Mounting option A allows for resolver size 15
- 3.) Consult factory for configurations not shown

Quantum Devices, Inc.
112 Orbison St., P.O. Box 100
Barneveld, WI 53507
(608) 924-3000
qdisales@quantumdev.com

OUTPUT WAVEFORMS

CCW Shaft Rotation as Viewed Looking at the Encoder Top

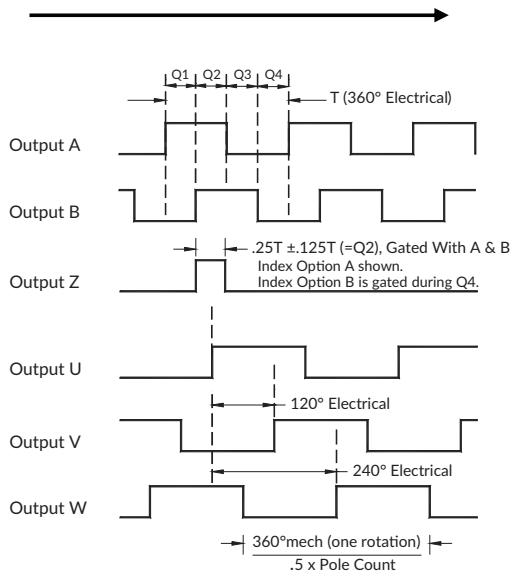

$$Q1 + Q2 = 0.5T \pm 0.125T$$

$$Q2 + Q3 = 0.5T \pm 0.125T$$

$$Q_n = 0.25T \pm 0.125T \quad (n = 1, 2, 3, 4)$$

ELECTRICAL PIN FUNCTIONS

Pin Number	Function
1	GND
2	Z
3	A
4	Vcc
5	B
6	U
7	V
8	W

ELECTRICAL SPECIFICATIONS

Input Voltage	5 VDC \pm 5%
Input Current Requirements	65 mA typical, 100 mA max plus interface loads
Input Ripple	2% peak to peak @ 5 VDC
Output Circuits	Single-ended TTL, sink or source 4 mA max (compatible with Renco PP option)
Incremental Output Format	Quadrature with A leading B for CCW rotation viewed from the encoder top
Max Operating Frequency	<ul style="list-style-type: none"> < 5000 PPR = 500 kHz or 15,000 RPM 5000 PPR = 675 kHz 1000LC-10P, 1024LC-10P, 2000LC-10P, 2048-10P and 2048LC-14P = 7000 RPM
Commutation Format	Three phase 4, 6, 8, 10 or 14 poles (other pole counts upon request)
Commutation Accuracy (UVW)	See EZ-Comm specifications
Interpolation Factors	1000/1024 PPR = 2x 2000/2048 PPR = 4x 2500 PPR = 5x 4000/4096 PPR = 8x 5000 PPR = 10x

ENVIRONMENTAL SPECIFICATIONS

Storage Temperature	-40 to 125°C
Operating Temperature	-30 to 115°C
IP Rating	IP40
Humidity	90% non-condensing
Vibration	20 g's @ 25 to 2,000 Hz
Shock	100 g's @ 6ms duration

MECHANICAL SPECIFICATIONS

Bore Minimum Diameter	Bore Size +0.0002"
Recommended Shaft Tolerance	+0.0000/-0.0005"
Minimum Shaft Engagement	0.400" [10.2 mm]
Allowable Shaft Runout	0.002" [0.05 mm] TIR (\pm 0.001" shaft radial play from initial shaft position of assembled encoder)
Allowable Axial Shaft Movement	\pm 0.010" [\pm 0.25 mm]
Mounting	A = 1.280" bolt circle/size 15 resolver, B = 1.812" bolt circle
Dynamic Commutation Adjustment Range	30° mechanical
Moment of Inertia	8.0 x 10 ⁻⁶ oz·in·s ²

*Quantum Devices, Inc. reserves the right to make changes in design, specifications and other information at any time without prior notice.

EZ-COMM SPECIFICATIONS

Encoder Commutation Accuracy after Alignment Process	U V W edge position error (max), after Power On until the first Index: 4P = 4°e, 6P = 6°e, 8P = 8°e, 10P = 10°e, 14P = 14°e.					
	U V W edge position error (max), after first Index after Power On:					
	Line Count	4 Pole	6 Pole	8 Pole	10 Pole	14 Pole
	500	1.0° e	2.4° e	3.4° e	3.8° e	
	512	1.0° e	2.8° e	3.4° e	5.2° e	
	1000	1.0° e	2.4° e	3.4° e	2.8° e	
	1024	1.0° e	2.8° e	3.4° e	3.2° e	
	2000	1.0° e	2.4° e	3.4° e	2.8° e	
	2048	1.0° e	2.8° e	3.4° e	3.2° e	4.5° e
	2500	1.0° e	2.1° e	3.2° e	3.4° e	
	4000		2.0° e	2.6° e	2.8° e	
	4096		2.0° e	2.6° e	2.7° e	
5000			2.5° e	2.9° e		
Note: Accuracy specification does not include motor winding pole pair position and magnetizing inaccuracies.						
Power on Latency	Power on to valid UVW states: 22 ms					

*Quantum Devices, Inc. reserves the right to make changes in design, specifications and other information at any time without prior notice.

EZ-COMM PROGRAMMABLE COMMUTATION ALIGNMENT

BEFORE ALIGNMENT PROCESS

The waveforms below are the QML35 EZ-Comm encoder Index (Z), U, V, and W phases in relation to the motor back electro motive force (BEMF) phases, prior to any alignment process. The red segments indicate the desired states to be aligned.

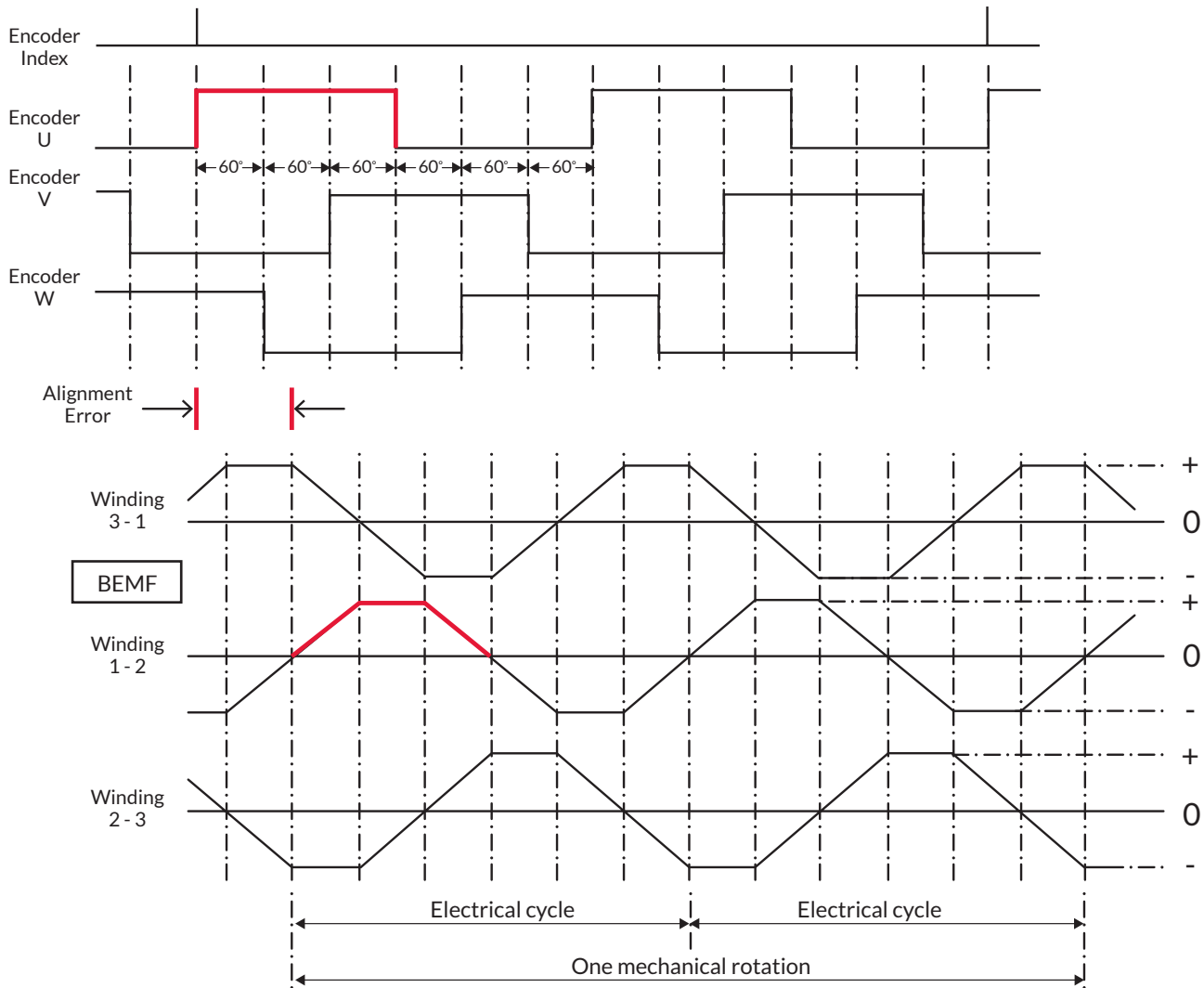

*Quantum Devices, Inc. reserves the right to make changes in design, specifications and other information at any time without prior notice.

EZ-COMM PROGRAMMABLE COMMUTATION ALIGNMENT

AFTER ALIGNMENT PROCESS

The waveforms below are the QML35 EZ-Comm encoder Index (Z), U, V, and W phases in relation to the motor back electro motive force (BEMF) phases, after the Semi-Automatic Commutator Alignment. The green arrow indicates motor shaft position where the alignment process occurred. The U, V, and W phases are aligned to the BEMF phases of the motor. The index marks are not repositioned.

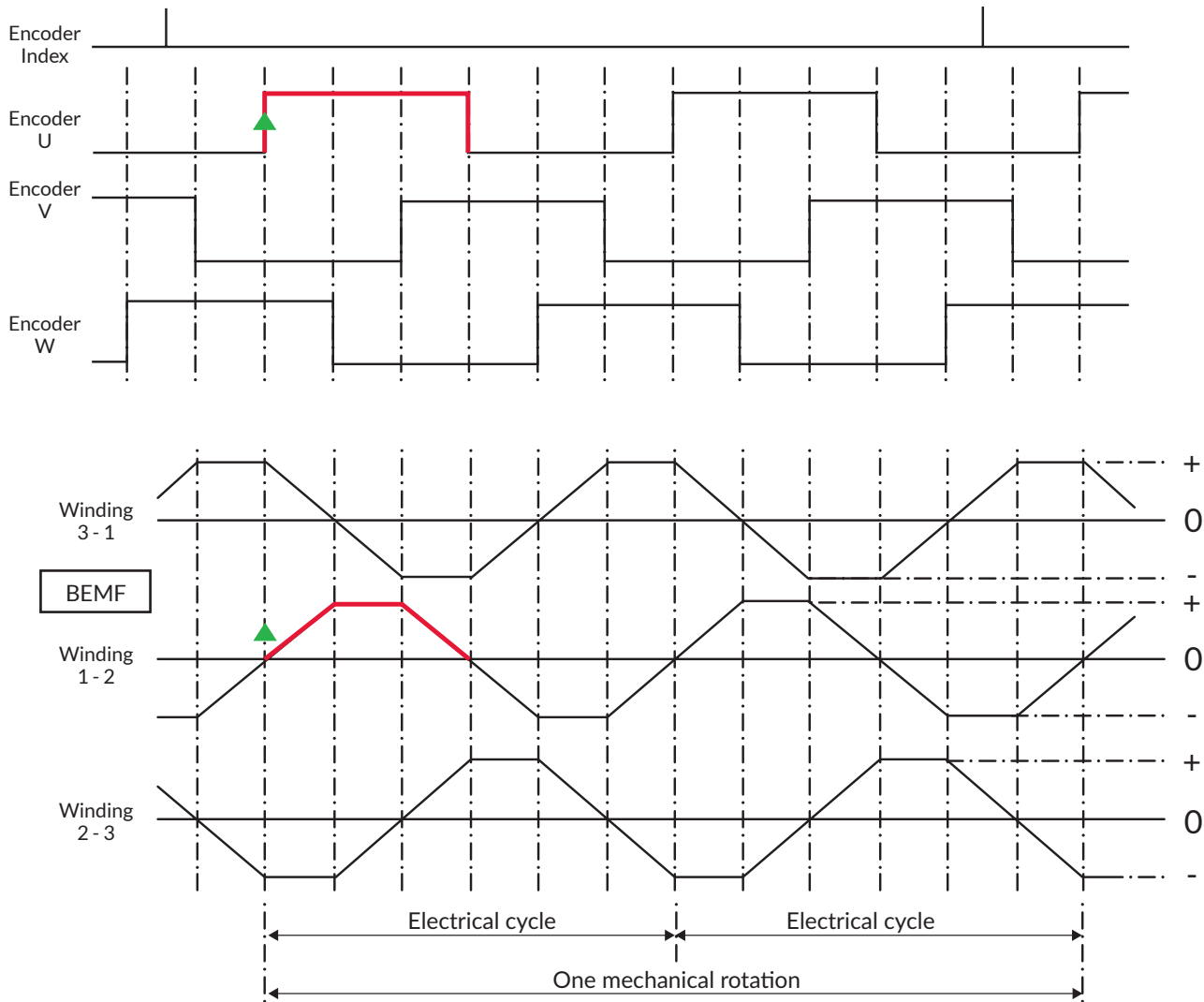

*Quantum Devices, Inc. reserves the right to make changes in design, specifications and other information at any time without prior notice.

MECHANICAL DIMENSIONS

Model QML35 EZ-Comm – 1.280" Bolt Circle (Mounting Option A)

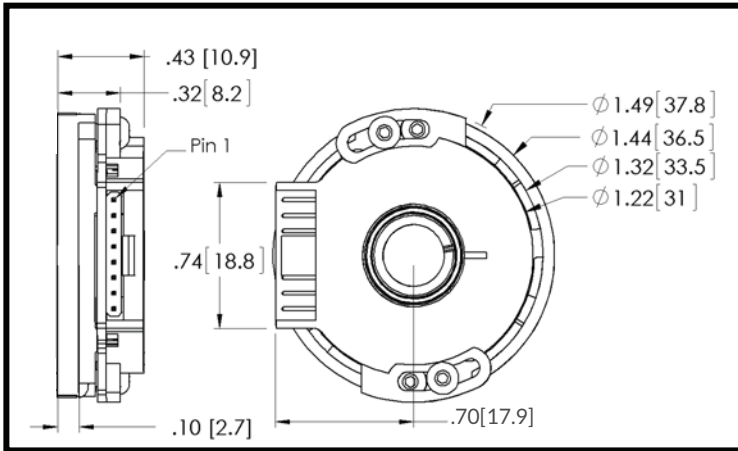

Model QML35 EZ-Comm – 1.812" Bolt Circle (Mounting Option B)

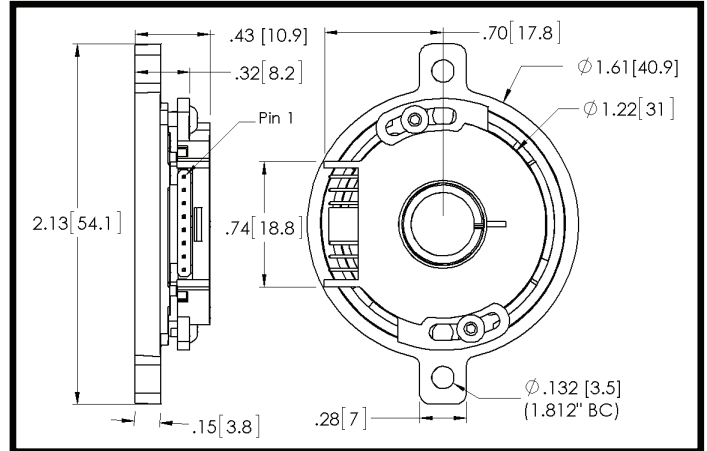

Note:

- Shown with Cover option A (hole in cover).
- Cover option B (closed) – Maximum shaft length up to 0.512" [13.0 mm]. Overall height increases from 0.43" [10.9 mm] to 0.57" [14.5 mm]. This additional height has a cylinder diameter 0.56" [14.2 mm], centered on the cover top.
- Cover option C (closed) – Maximum shaft length up to 0.450" [11.4 mm]. Overall height increases from 0.43" [10.9 mm] to 0.51" [13.0 mm]. This additional height has a cylinder diameter 0.56" [14.2 mm], centered on the cover top.

MOUNTING REQUIREMENTS

Mounting Option A (1.280" Bolt Circle)

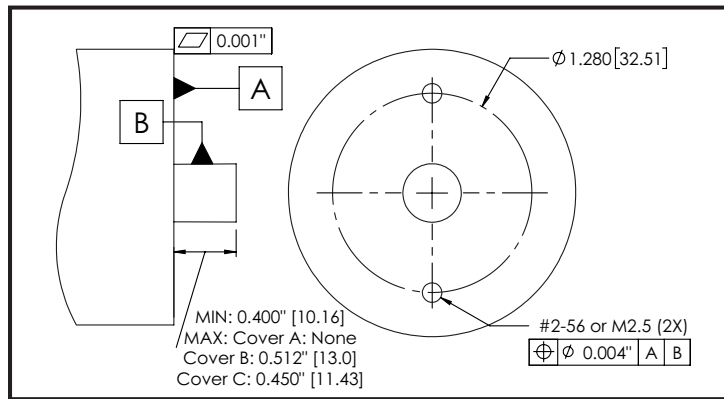

Mounting Option B (1.812" Bolt Circle)

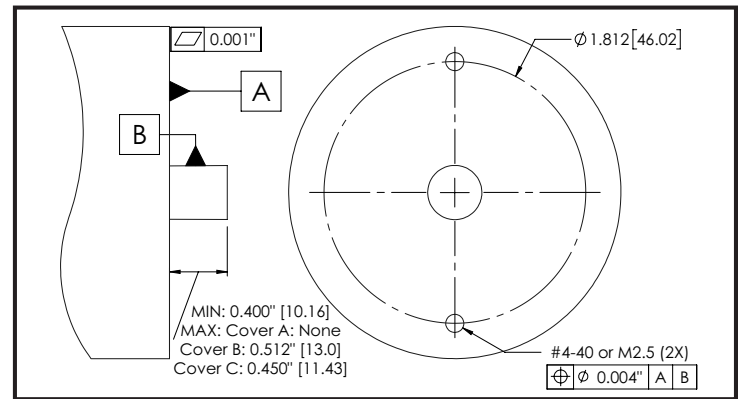

Servo Size 15 Mounting (Mounting Option A)

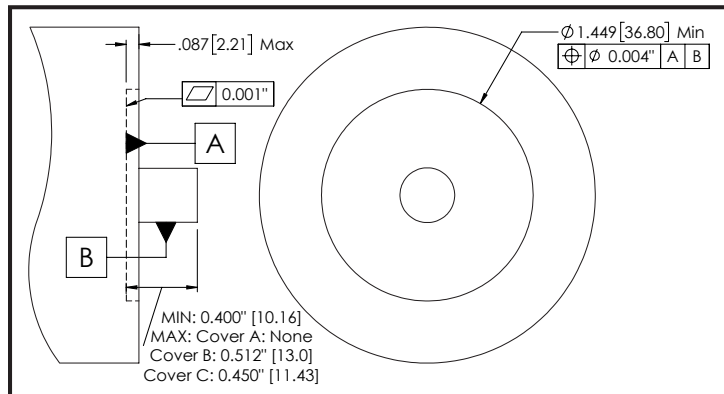

Patent Protection:

- US Patent 9,857,205
- US Patent 6,563,108

*Quantum Devices, Inc. reserves the right to make changes in design, specifications and other information at any time without prior notice.

SELECTION CHARTS

MOUNTING OPTION A (1.280" BOLT CIRCLE)							
#3-48 x 1/16" Set Screw 1/16" set screw is required for Bore Size options E (8 mm), M (0.3125") and N (0.375")				#3-48 x 3/32" Set Screw 3/32" set screw has deeper hex pocket to improve assembly tool life			
Mounting Screws		Mounting Screws with Thread Lock		Mounting Screws		Mounting Screws with Thread Lock	
English	Metric	English	Metric	English	Metric	English	Metric
Option A	Option B	Option D	Option E	Option F	Option G	Option H	Option J

MOUNTING OPTION B (1.812" BOLT CIRCLE)							
#3-48 x 1/16" Set Screw 1/16" set screw is required for Bore Size options E (8 mm), M (0.3125") and N (0.375")				#3-48 x 3/32" Set Screw 3/32" set screw has deeper hex pocket to improve assembly tool life			
Mounting Screws		Mounting Screws with Thread Lock		Mounting Screws		Mounting Screws with Thread Lock	
English	Metric	English	Metric	English	Metric	English	Metric
Option K	Option L	Option M	Option N	Option P	Option Q	Option R	Option S

Note:

- 1.) Bore Size options E (8 mm), M (0.3125") and N (0.375") are limited to Hardware options A, B, D, E, K, L, M or N. These Hardware options can optionally be used with all other standard Bore Size options.
- 2.) Hardware options F, G, H, J, P, Q, R and S have longer #3-48 set screws (3/32") with a deeper hex pocket to improve assembly tool life. These Hardware options are not compatible with Bore Size options E (8 mm), M (0.3125") or N (0.375").
- 3.) Hardware options D, E, H, J, M, N, R and S contain a thread lock which is applied to the mounting screws only. This preapplied thread locking product contains a microencapsulated epoxy resin that is suspended in a hardener. The force of thread engagement crushes the microscopic capsules of epoxy resin, mixing the reactant components, and initiating a chemical reaction which locks the parts together. This product series provides consistent and predictable torque values and requires no heat or primers for curing. Product - ND Industries 593S.

HARDWARE SELECTION BREAKOUT

	Option A	Option B	Option D	Option E	Option F	Option G	Option H	Option J
Set Screws (Qty. 2 each)	Black Ox #3-48 x 1/16" 0.050" Hex (Torque = 18 - 22 oz-in) Part Number 1829ZG014	Black Ox #3-48 x 1/16" 0.050" Hex (Torque = 18 - 22 oz-in) Part Number 1829ZG014	Black Ox #3-48 x 1/16" 0.050" Hex (Torque = 18 - 22 oz-in) Part Number 1829ZG014	Black Ox #3-48 x 1/16" 0.050" Hex (Torque = 18 - 22 oz-in) Part Number 1829ZG014	Black Ox #3-48 x 3/32" 0.050" Hex (Torque = 18 - 22 oz-in) Part Number 1829ZG015	Black Ox #3-48 x 3/32" 0.050" Hex (Torque = 28 - 32 oz-in) Part Number 1829ZG015	Black Ox #3-48 x 3/32" 0.050" Hex (Torque = 28 - 32 oz-in) Part Number 1829ZG015	Black Ox #3-48 x 3/32" 0.050" Hex (Torque = 28 - 32 oz-in) Part Number 1829ZG015
Mounting Screws (Qty. 2 each)	#2-56 x 1/4" Button Head, 0.050" Hex (Torque = 45 - 51 oz-in) Part Number 1834ZG002	M2.5 x 6 mm Button Head (max dia. 4.5 mm) 1.5 mm Hex (Torque = 45 to 51 oz-in) Part Number 1834ZG050	#2-56 x 1/4" Button Head, 0.050" Hex with thread lock (Torque = 45 - 51 oz-in) Part Number 1834AG102	M2.5 x 6 mm Button Head (max dia. 4.5 mm) 1.5 mm Hex with thread lock (Torque = 45 - 51 oz-in) Part Number 1834AG150	#2-56 x 1/4" Button Head, 0.050" Hex (Torque = 45 - 51 oz-in) Part Number 1834ZG002	M2.5 x 6 mm Button Head (max dia. 4.5 mm) 1.5 mm Hex (Torque = 45 - 51 oz-in) Part Number 1834ZG050	#2-56 x 1/4" Button Head, 0.050" Hex with thread lock (Torque = 45 - 51 oz-in) Part Number 1834AG102	M2.5 x 6 mm Button Head (max dia. 4.5 mm) 1.5 mm Hex with thread lock (Torque = 45 - 51 oz-in) Part Number 1834AG150
Cover Screws (Qty. 2 each)	Plastite 48-2, thread 2-28, length 1/4", Torx Plus IP7 (Torque = 37 - 43 oz-in) Part Number 1826ZG002	Plastite 48-2, thread 2-28, length 1/4", Torx Plus IP7 (Torque = 37 - 43 oz-in) Part Number 1826ZG002	Plastite 48-2, thread 2-28, length 1/4", Torx Plus IP7 (Torque = 37 - 43 oz-in) Part Number 1826ZG002	Plastite 48-2, thread 2-28, length 1/4", Torx Plus IP7 (Torque = 37 - 43 oz-in) Part Number 1826ZG002	Plastite 48-2, thread 2-28, length 1/4", Torx Plus IP7 (Torque = 37 - 43 oz-in) Part Number 1826ZG002	Plastite 48-2, thread 2-28, length 1/4", Torx Plus IP7 (Torque = 37 - 43 oz-in) Part Number 1826ZG002	Plastite 48-2, thread 2-28, length 1/4", Torx Plus IP7 (Torque = 37 - 43 oz-in) Part Number 1826ZG002	Plastite 48-2, thread 2-28, length 1/4", Torx Plus IP7 (Torque = 37 - 43 oz-in) Part Number 1826ZG002
	Option K	Option L	Option M	Option N	Option P	Option Q	Option R	Option S
Set Screws (Qty. 2 each)	Black Ox #3-48 x 1/16" 0.050" Hex (Torque = 18 - 22 oz-in) Part Number 1829ZG014	Black Ox #3-48 x 1/16" 0.050" Hex (Torque = 18 - 22 oz-in) Part Number 1829ZG014	Black Ox #3-48 x 1/16" 0.050" Hex (Torque = 18 - 22 oz-in) Part Number 1829ZG014	Black Ox #3-48 x 1/16" 0.050" Hex (Torque = 18 - 22 oz-in) Part Number 1829ZG014	Black Ox #3-48 x 3/32" 0.050" Hex (Torque = 28 - 32 oz-in) Part Number 1829ZG015	Black Ox #3-48 x 3/32" 0.050" Hex (Torque = 28 - 32 oz-in) Part Number 1829ZG015	Black Ox #3-48 x 3/32" 0.050" Hex (Torque = 28 - 32 oz-in) Part Number 1829ZG015	Black Ox #3-48 x 3/32" 0.050" Hex (Torque = 28 - 32 oz-in) Part Number 1829ZG015
Mounting Screws (Qty. 2 each)	#4-40 x 5/16" Button Head, 0.062" Hex (Torque = 45 - 52 oz-in) Part Number 1835ZG004	M2.5 x 8 mm Button Head, 1.5 mm Hex (Torque = 45 - 51 oz-in) Part Number 1834ZG051	#4-40 x 5/16" Button Head, 0.062" Hex with thread lock (Torque = 45 - 51 oz-in) Part Number 1835ZG104	M2.5 x 8 mm Button Head, 1.5 mm Hex with thread lock (Torque = 45 - 51 oz-in) Part Number 1834AG151	#4-40 x 5/16" Button Head, 0.062" Hex (Torque = 45 - 51 oz-in) Part Number 1835ZG004	M2.5 x 8 mm Button Head, 1.5 mm Hex (Torque = 45 - 51 oz-in) Part Number 1834ZG051	#4-40 x 5/16" Button Head, 0.062" Hex with thread lock (Torque = 45 - 51 oz-in) Part Number 1835ZG104	M2.5 x 8 mm Button Head, 1.5 mm Hex with thread lock (Torque = 45 - 51 oz-in) Part Number 1834AG151
Cover Screws (Qty. 2 each)	Plastite 48-2, thread 2-28, length 1/4", Torx Plus IP7 (Torque = 37 - 43 oz-in) Part Number 1826ZG002	Plastite 48-2, thread 2-28, length 1/4", Torx Plus IP7 (Torque = 37 - 43 oz-in) Part Number 1826ZG002	Plastite 48-2, thread 2-28, length 1/4", Torx Plus IP7 (Torque = 37 - 43 oz-in) Part Number 1826ZG002	Plastite 48-2, thread 2-28, length 1/4", Torx Plus IP7 (Torque = 37 - 43 oz-in) Part Number 1826ZG002	Plastite 48-2, thread 2-28, length 1/4", Torx Plus IP7 (Torque = 37 - 43 oz-in) Part Number 1826ZG002	Plastite 48-2, thread 2-28, length 1/4", Torx Plus IP7 (Torque = 37 - 43 oz-in) Part Number 1826ZG002	Plastite 48-2, thread 2-28, length 1/4", Torx Plus IP7 (Torque = 37 - 43 oz-in) Part Number 1826ZG002	Plastite 48-2, thread 2-28, length 1/4", Torx Plus IP7 (Torque = 37 - 43 oz-in) Part Number 1826ZG002

*Quantum Devices, Inc. reserves the right to make changes in design, specifications and other information at any time without prior notice.

CABLE ACCESSORIES

(2161AG039, 2162AG019)

Consult Factory for Custom Lengths

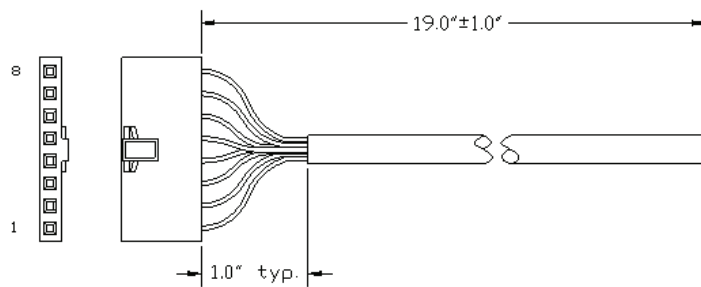
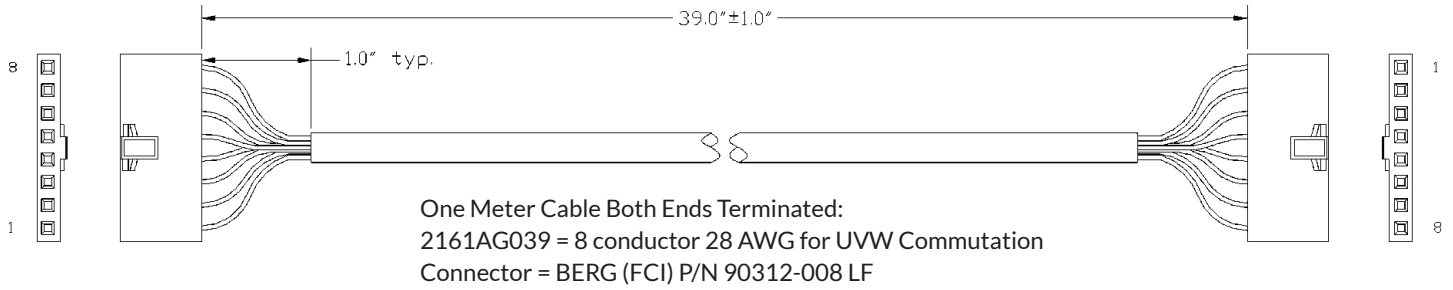

Pin Number	Encoder Pin Function	2161AG039 2162AG019 Wire Color
1	GND	Black
2	Z	Orange
3	A	Yellow
4	Vcc	Red
5	B	Blue
6	U	Green
7	V	Brown
8	W	White

Note:

1. Cable has internal foil shield with 28 AWG drain wire trimmed to jacket edge
2. Unused wires to be locally isolated from adjacent signal wires, Vcc and GND to prevent damage to encoder signals

Note: BERG (FCI) P/N 90312-008 LF connector using 77138-001LF pins is compatible with 26-30 AWG wire.

INSTALLATION INSTRUCTIONS FOR 1.280" BOLT CIRCLE

QM35 Connector shown in illustrations

STEP 1

Rotate printed circuit board (PCB) to expose the mounting holes. This is the Lock position. Mounting/motor surface must be clean and flat.

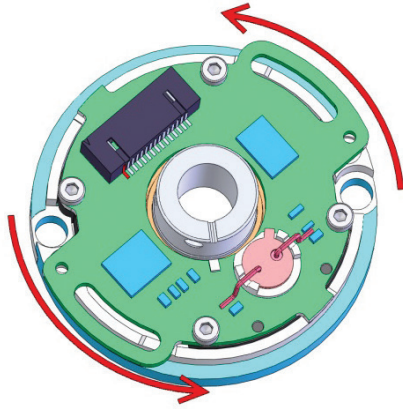

STEP 2

A. Install mounting screws through encoder into mounting/motor surface. Insert 1-2 turns. **DO NOT tighten screws.**

Note: Alignment of Z mark on hub to white mark on PCB is NOT required.

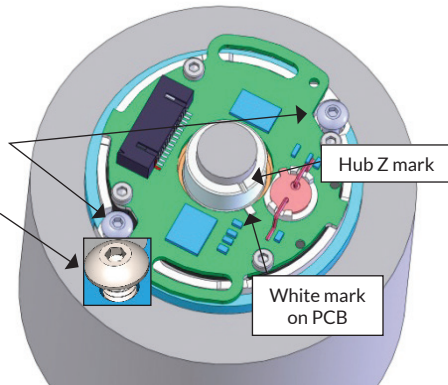

STEP 3

A. Press down on the hub with a force between 150 g (0.33 lb) and 700 g (1.5 lb). This will center the encoder assembly to the motor shaft.

B. Using slight forefinger and thumb force, verify no radial (side-to-side) movement of the encoder occurs.

Illustrated is accessory Q-Scale p/n 2160AG276. Proper downward force is indicated when pin is between the force lines.

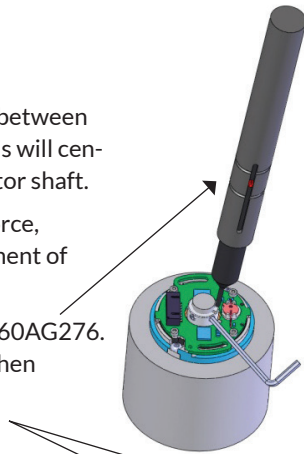

STEP 4

A. Tighten hub set screws to motor shaft.
#3-48 x 1/16" screw = 18-22 oz-in
#3-48 x 3/32" screw = 28-32 oz-in

B. The downward force on the hub can be removed.

C. Tighten mounting screws to 45-51 oz-in

TIP: Place Q-Scale point within the Z mark of hub.

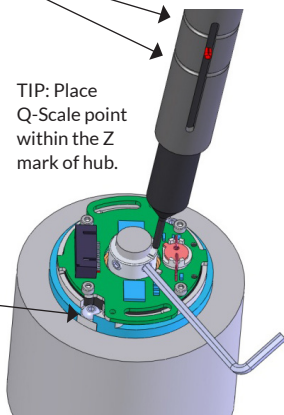

STEP 5

Place cover on encoder. Observe the cover dowel pins positioned into mating PCB holes.

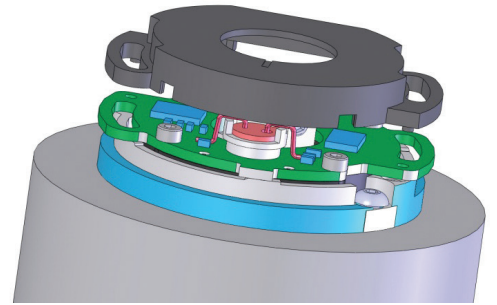

STEP 6

A. Twist cover/ PCB to expose screw holes for cover screws.

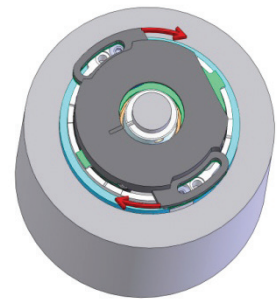

B. Install cover screws and tighten to 37-43 oz-in.

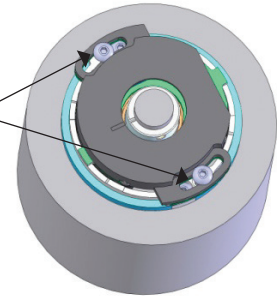

C. Install cable to complete installation.

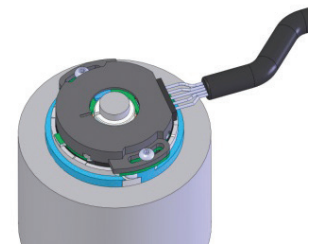

Note: Refer to Hardware Selection Breakout chart for driver sizes.

*Quantum Devices, Inc. reserves the right to make changes in design, specifications and other information at any time without prior notice.

QML35 EZ-COMM PROGRAMMING INSTRUCTIONS

QM35 Connector shown in illustrations

QML35 EZ-COMM SET UP:

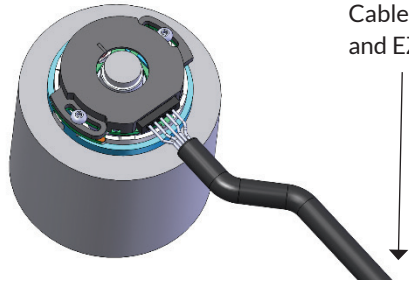

Connect Programmer Cable between encoder and EZ-Comm Programmer

EZ-COMM PROGRAMMER INDICATORS

LED1 Flashing: Rotate Shaft to Align Commutation.

LED1 Steady: Commutation Alignment Complete.

LED2 Flashing: Rotate Shaft to Verify Installation.

LED2 Steady: Encoder Installation is Good.

LED3 Flashing: Error (repeat installation).

LED4 Steady: Encoder has Power.

QML35 EZ-COMM PROGRAMMING KIT, P/N: 2174AG003

Includes:

- EZ-Comm Programmer
- 19" Programmer Cable p/n: 2174AG004
- 9VDC, 6W Power Supply

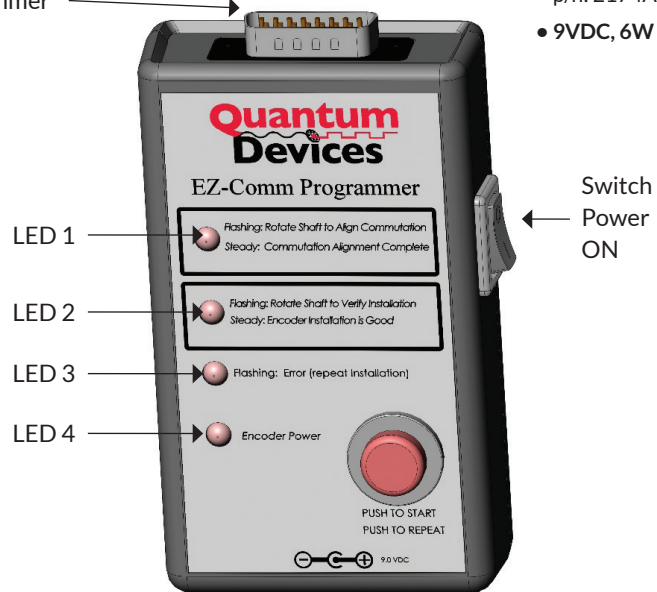

Plug power supply cube into 110 VAC supply. Connect +9v DC power plug into socket.

EZ-COMM ALIGNMENT PROCEDURE

- Energize appropriate motor windings to align shaft to U rise position.
- Press button to Start Alignment process.
 - LED 1 will flash.
 - LED 4 will illuminate, indicating power applied to encoder.
- Remove power from motor windings applied in step A.
- Rotate motor shaft (~one rotation) to align commutation.
 - LED 1 will light steady when align is complete.
 - LED 2 will flash.
- Rotate motor shaft (~one rotation) to verify installation.
 - LED 2 will light steady when installation verification is complete.
 - LED 4 will extinguish removing power from encoder.

For multiple alignments, the power switch on the box side can remain in the ON position.

Rotational speed limited to 350RPM.

PROGRAMMER PINOUT

- Pin 1 = Encoder power
- Pin 2 = Ground
- Pin 3 = Chan U
- Pin 4 = Chan V
- Pin 5 = Chan W

REMOTE/AUTOMATED CONNECTION

- Pin 7 = Input Open Collector – ground and release to Start Alignment process, alignment procedure step B.
- Pin 8 = Output TTL logic High during alignment procedure steps B, C and D.
- Pin 15 = Output TTL logic High during alignment procedure step E.
- Pin 14 = Output TTL logic High upon complete of step E to signal the installation was verified (passing).
- Pin 13 = Output TTL High if an installation error occurs.

Repeat next assembly: First ground and release of Pin 7 to clear Pass or Fail from the previous alignment.