

THE INFORMATION CONTAINED IN THIS DRAWING IS THE SOLE PROPERTY OF THE SSC CONTROLS COMPANY AND IS NOT TO BE USED, REPRODUCED, OR DISCLOSED WITHOUT THE EXPRESS WRITTEN PERMISSION OF THE SSC CONTROLS COMPANY.

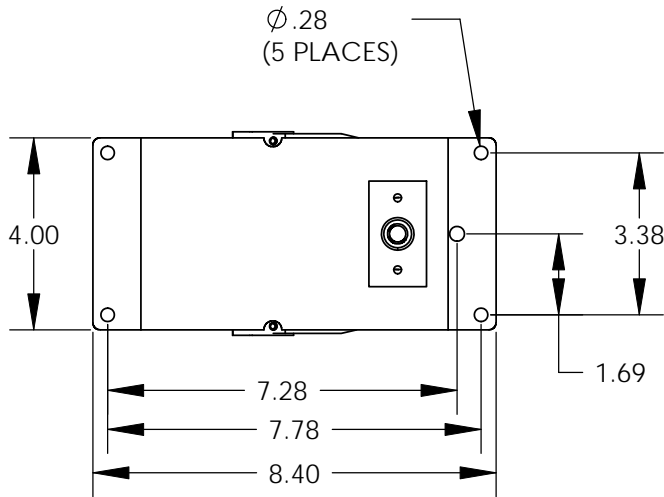
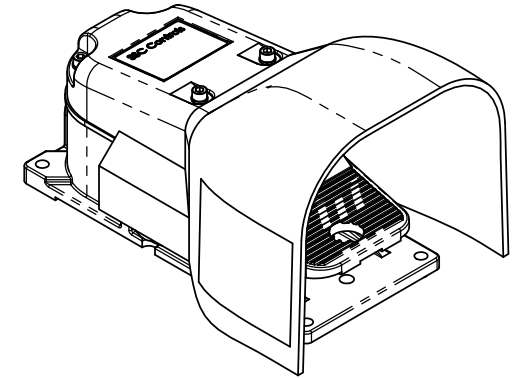
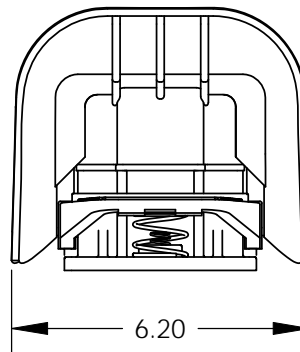
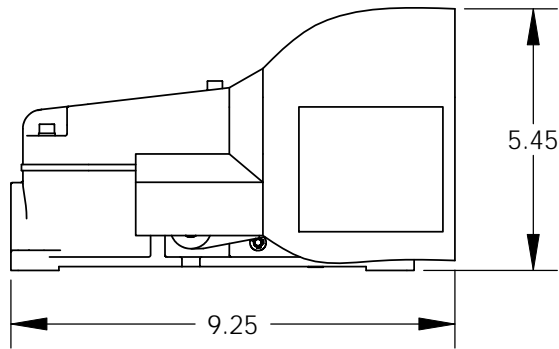

REPLACEMENT PARTS PRICING:  
 SWITCH, 20 AMP, SPDT (P/N 11416) - \$15.00  
 RUBBER GASKET (P/N 11404) - \$5.00  
 GUARD KIT (P/N 11401-KIT) - \$35.00  
 (INCLUDES GUARD, GASKET, AND SCREWS)  
 COMPRESSION SPRING, 1.2" O.D. (P/N 10004-3) - \$ 5.00  
 POTENTIOMETER (P/N 11485-1K FOR 1,000 OHMS, 11485-5K  
 FOR 5,000 OHMS, OR 11485-10K FOR 10,000 OHMS) - \$24.00

CSA/UL ENCLOSURE TYPE 2, 4, & 13  
 IEC ENCLOSURE IP-56  
 APPROXIMATE WEIGHT: 5 LBS

CONTACT INFORMATION:  
 THE SSC CONTROLS CO.  
 PH: 440-205-1600  
 FAX: 440-205-1700  
 EMAIL: MAIL@SSCCONTROLS.COM  
 WEBSITE: WWW.SSCCONTROLS.COM

ALL DIMENSIONS ARE FOR REFERENCE ONLY.

## The SSC Controls Company

8909 EAST AVENUE  
 MENTOR, OHIO, USA 44060

|  |                     |     |  |
|--|---------------------|-----|--|
| UNLESS OTHERWISE SPECIFIED,<br>DIMENSIONS ARE IN INCHES<br>AND TOLERANCES ARE AS FOLLOWS:<br><br>FOR 2 DECIMAL PLACES: ± .02<br>FOR 3 DECIMAL PLACES: ± .002<br>FOR ANGLES: ± .5 OF A DEGREE | DRAWING INFORMATION |     | DRAWING NAME:  |
|  | DRAWN BY:           | BAM | <b>G700 EXTERIOR DIMS. AND<br/>REPLACEMENT PARTS</b> |
|  | CHECKED BY:         | JEM |  |
|  | DATE:               | N/A | DRAWING NUMBER:                                      |
|  | SCALE:              | 1:4 | N/A  |