

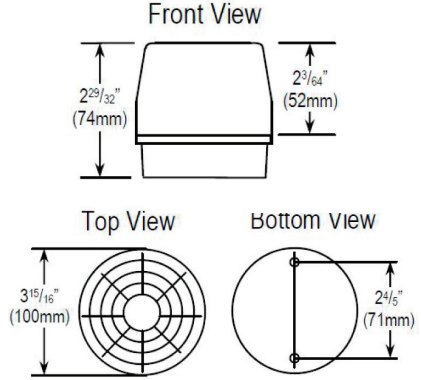

The RSA-24V is a remote LED strobe light with audible. It is ideal for applications that require timing, paging and alarm signalling, including equipment malfunction alert and security warning. The strobe has multiple user selectable flash patterns and the audible can be turned on or off independently of the strobe.

The device comes with a wall mounting bracket for easy installation. Visual / audible alarm devices for gas detection systems should be mounted at higher elevations, if possible 2000 millimeters (6.5 feet) to 2400 millimeters (8 feet) AFF, or as stated by local codes and regulations. It may be used indoors or outdoors. Ideal for connecting to the relay of an SCC, DCC or FCS Controller or an LPT-A, LPT-B or LPT-M transmitter. May also be connected to a CGAS analog or digital transmitter with Option -RLY.

### TECHNICAL DRAWING



### TECHNICAL SPECIFICATIONS

MECHANICAL	
Enclosure	Polycarbonate
Size	8.9 cm diameter / 3.5 in diameter
Lens Colour	Red
# of Strobe Patterns	6
Operating Life	50,000 hours (approx)

### AUDIBLE CHARACTERISTICS

Sound Pressure Level	100 dB @ 30 cm (100 dB @ approx. 2 ft)
Tone/Pulse Rate	Continuous wobble

### ELECTRICAL

Power Requirements	24 VDC or 24 VAC
Current Draw	300 mA@24 VDC
Backup Battery	9V, not included

### ENVIRONMENTAL

Operating Temperature	-20°C to 65°C (-4°F to 149°F)
-----------------------	-------------------------------

### CERTIFICATION

Conforms to IP65  
 Certification requirements are met if this device is connected to a CSA approved CET Controller, Self Contained Controller, Transmitter or a CSA approved Class 2 power supply

### PRODUCT CODES

RSA-24V	Remote LED strobe light with audible, red lens, 24 VDC/VAC, 8.9 cm / 3.5" dia, comes with mounting bracket
---------	--

### KEY FEATURES

- » Low profile, lightweight, very bright, long operating life
- » Strobe and audible can be run together or strobe alone without audible
- » Multiple flash patterns easily configured using dip switches
- » Jumper controlled audible ON / OFF
- » Wall mount (hardware included)

### APPLICATIONS

- » Parking Garages
- » Equipment/ Machinery Rooms
- » Manufacturing Plants
- » Food Processing Plants
- » Power Generation Plants
- » ... and many more

