

Metal Protective Guards help to protect against impact, abrasive damage, theft and vandalism to your gas detection system. Ideal for environments where vehicles could potentially back into the equipment, or in ice arenas where hockey pucks could hit the equipment or in locations where the general public might feel inclined to try to tamper with the equipment.

The Standard Metal Guard is available in a small size that fits over transmitters or a larger size that fits over CET controllers. It is made from 16-gauge powder coated steel with $\frac{1}{2}$ " (13 mm) square openings in the front to allow the gas and air to flow unobstructed through to the sensor.

The Metal Splash Guard is available in a small size that fits over transmitters and is made of 16-gauge powder coated steel with louvers and a protective top cover to deflect water. The Metal Splash Guard model is recommended for use in applications where sticky gases are being monitored (such as Ozone, Chlorine, Chlorine dioxide, Hydrogen chloride or Hydrogen cyanide) and protection from water ingress is required.

There are four slotted mounting holes making for easy installation and removal for gas detector servicing easy.

KEY FEATURES

- » Durable
- » Easy to install
- » Removeable
- » Discreet
- » Offers protection from impact, theft or vandalism
- » Protects sticky gas sensors in wet environments

APPLICATIONS

- » Parking Garages
- » Loading Docks
- » Fire Houses
- » Vehicle Detailing Bays
- » Hospitals / Laboratories
- » Fisheries / Hatcheries
- » Commercial Swimming Pools
- » Wineries / Breweries
- » ... and many more

TECHNICAL DRAWING

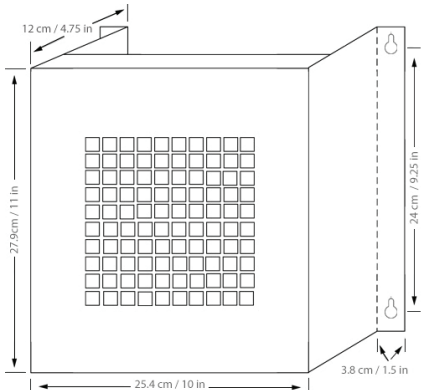
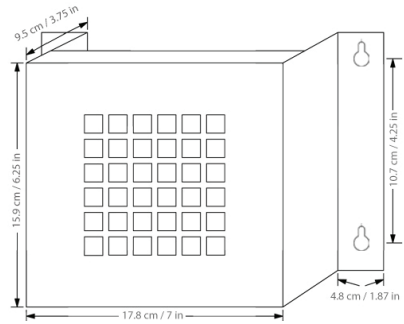
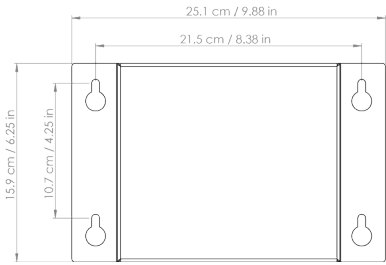



GAS DETECTION OPTIONS & ACCESSORIES DATASHEET

Metal Protective Guards for Transmitters

OPTIONS & ACCESSORIES

TECHNICAL SPECIFICATIONS

MECHANICAL	
Material	16 gauge powder coated steel
Weight	Small Guard 800 g / 1.7 lbs Splash Guard 1,000 g / 2.2 lbs Large Guard 1,700 g / 3.8 lbs
Small Guards Size	17.8 cm / 7 in wide (coverage area) 25 cm / 9.88 in wide (total) 15.9 cm / 6.25 in tall 9.5 cm / 3.75 in deep
Anchoring Holes	21.3 cm / 8.38 in horizontally 10.7 cm / 4.25 in vertically
Large Guard Size	25.4 cm / 10 in wide (coverage area) 32.7 cm / 12.9 in wide (total) 27.9 cm / 11 in tall 12 cm / 4.75 in deep
Anchoring Holes	28.7 cm / 11.31 in horizontally 24 cm / 9.5 in vertically

PRODUCT CODES

SCS-8000-RSG	Small, 16 gauge galvanized metal guard for transmitters
SCS-8000-WSG	Small, 16 gauge powder coated metal guard with splash cover for transmitters
SCS-8000-SPG	Large, 16 gauge powder coated metal guard for controllers

