

2D/3D Profile Sensor

MLWL033

LASER

weCat3D

Part Number



- Blue light for applications on metal, organic or semi-transparent materials
- Ecolab
- IP69K
- Up to 12 million measuring points per second

2D/3D Profile Sensors project a laser line onto the object to be detected and generate an accurate, linearized height profile with an internal camera which is set up at a triangulation angle. Thanks to its uniform, open interface, the weCat3D series can be incorporated by means of the DLL program library or the GigE Vision standard without an additional control unit. Alternatively, wenglor offers its own software packages for implementing your application.



Technical Data

Optical Data	
Working range Z	300...1000 mm
Measuring range Z	700 mm
Measuring range X	280...830 mm
Linearity Deviation	175 µm
Resolution Z	27...162 µm
Resolution X	181...446 µm
Light Source	Laser (blue)
Wavelength	405 nm
Service Life (T = +25 °C)	20000 h
Laser Class (EN 60825-1)	2M

Environmental conditions	
Ambient temperature	0...45 °C
Storage temperature	-20...70 °C
Max. Ambient Light	5000 Lux
EMC	DIN EN 61000-6-2; 61000-6-4
Shock resistance per DIN IEC 68-2-27	30 g / 11 ms
Vibration resistance per DIN IEC 60068-2-6	6 g (10...55 Hz)

Electrical Data	
Supply Voltage	18...30 V DC
Current Consumption (U _b = 24 V)	300 mA
Subsampling	350...6000 /s
Output rate	180...6000 /s
Inputs/Outputs	4
Switching Output Voltage Drop	< 1,5 V
Switching Output/Switching Current	100 mA
Short Circuit Protection	yes
Reverse Polarity Protection	yes
Overload Protection	yes
Interface	Ethernet TCP/IP
Baud Rate	100/1000 Mbit/s
Protection Class	III
FDA Accession Number	2110262-000

Mechanical Data	
Housing Material	Stainless steel 1.4305
Degree of Protection	IP69K
Cable Length	5 m
Bending Radius	87 mm
Optic Cover	Plastic, PMMA
Cable Jacket Material	Plastic, TPE

Safety-relevant Data	
MTTFd (EN ISO 13849-1)	3706,54 a

Push-Pull	●
Connection Diagram No.	233 263

Complementary Products

Control Unit	
Software	
Switch EHSS001	

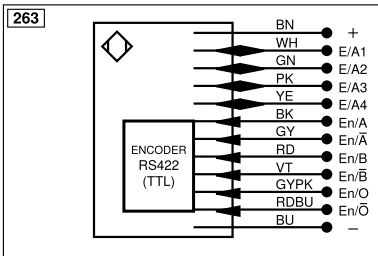
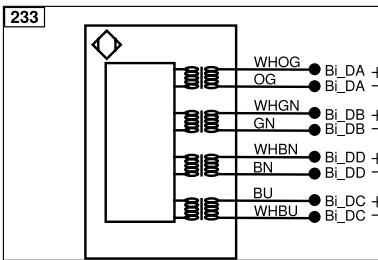
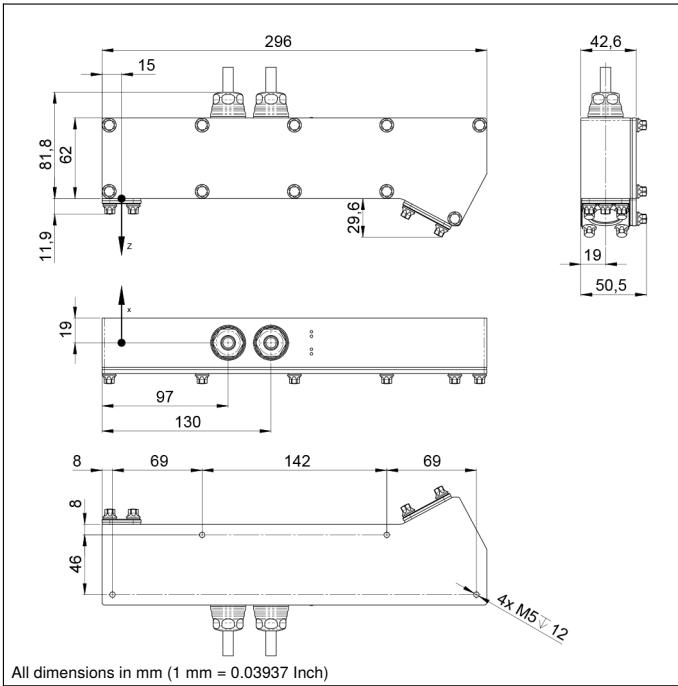

Legend			
+	Supply Voltage +	nc	Not connected
-	Supply Voltage 0 V	U	Test Input
~	Supply Voltage (AC Voltage)	Ü	Test Input inverted
A	Switching Output (NO)	W	Trigger Input
Ā	Switching Output (NC)	W-	Ground for the Trigger Input
V	Contamination/Error Output (NO)	O	Analog Output
ȳ	Contamination/Error Output (NC)	O-	Ground for the Analog Output
E	Input (analog or digital)	BZ	Block Discharge
T	Teach Input	Amv	Valve Output
Z	Time Delay (activation)	a	Valve Control Output +
S	Shielding	b	Valve Control Output 0 V
RxD	Interface Receive Path	SY	Synchronization
TxD	Interface Send Path	SY-	Ground for the Synchronization
RDY	Ready	E+	Receiver-Line
GND	Ground	S+	Emitter-Line
CL	Clock	±	Grounding
E/A	Output/Input programmable	SnR	Switching Distance Reduction
IO-Link	IO-Link	Rx+/-	Ethernet Receive Path
PoE	Power over Ethernet	Tx+/-	Ethernet Send Path
IN	Safety Input	Bus	Interfaces-Bus A(+)/B(-)
OSSD	Safety Output	La	Emitted Light disengageable
Signal	Signal Output	Mag	Magnet activation
BI_D+/-	Ethernet Gigabit bidirect. data line (A-D)	RES	Input confirmation
ENo RS422	Encoder 0-pulse 0/0 (TTL)	EDM	Contactor Monitoring
PT	Platinum measuring resistor	ENARs422	Encoder A/Ā (TTL)
		ENBrs422	Encoder B/B̄ (TTL)
		ENA	Encoder A
		ENb	Encoder B
		AMIN	Digital output MIN
		AMAX	Digital output MAX
		Aok	Digital output OK
		SY In	Synchronization In
		SY OUT	Synchronization OUT
		OLT	Brightness output
		M	Maintenance
		rsv	Reserved
			Wire Colors according to DIN IEC 60757
		BK	Black
		BN	Brown
		RD	Red
		OG	Orange
		YE	Yellow
		GN	Green
		BU	Blue
		VT	Violet
		GY	Grey
		WH	White
		PK	Pink
		GNYE	Green/Yellow

Measuring field X, Z

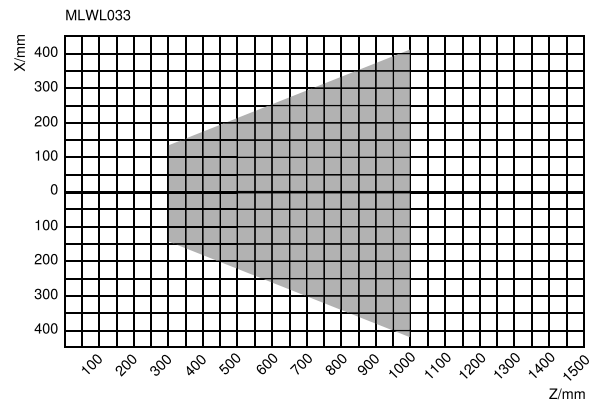

Z = Working distance
 X = Measuring Range

