

Flat Dome Light

Infrared, 200 × 200 mm

LFDI201

Part Number



- **Easy and flexible installation**
- **High homogeneity**
- **High performance: high intensity even in continuous mode**
- **No external control required**

The LFD series flat dome lights are high-diffuse lights with camera connection. Due to their intense luminous flux and high homogeneity, they are perfectly suited for large-area applications such as robot-assisted pick and place. They can be used in continuous mode or synchronized with the Machine Vision Camera in strobe mode via PNP or NPN inputs. The illumination is extremely homogeneous with very narrow edges (4 mm), so the usable surface is very large and integration is very easy – thanks, among other things, to the T-slot mounting and anchor point around the housing. The camera and lighting can be easily coupled using the special camera brackets on the back of the lighting. The housing is designed like an LED backlight, but has a camera hole in the middle for positioning the camera.

Technical Data

Optical Data	
Light Source	Infrared Light
Wavelength	850 nm
Risk Group (EN 62471)	1
Infrared light output	119 W/m ²
Electrical Data	
Supply Voltage	21,6...26,4 V DC
Power	27,6 W
Current Consumption Continuous Mode (U _b = 24 V)	1,15 A
Rise time	15 μs
Fall time	10 μs
Input signal	PNP/NPN
Temperature Range	-10...40 °C
Storage temperature	-20...60 °C
Short Circuit Protection	yes
Reverse Polarity Protection	yes
Overload Protection	yes
Protection Class	III
Dimming	0...10 V ± 100...30%
Overdrive	no
Mechanical Data	
Luminous Field Length (L)	200 mm
Luminous Field Width (W)	200 mm
Luminous Field	200 × 200 mm
Housing Material	Aluminum, anodised
Degree of Protection	IP40
Optic Cover	Plastic, PMMA
Connection	M12 × 1; 5-pin
Max. cable length	10 m
Camera aperture inner diameter	65 mm
Function	
Operating modes	Continuous, Strobe
Connection Diagram No.	007
Control Panel No.	T16
Suitable Mounting Technology No.	926

Complementary Products

ZC4G003 connection cable
ZDCG004 connection cable
ZDCG005 connection cable

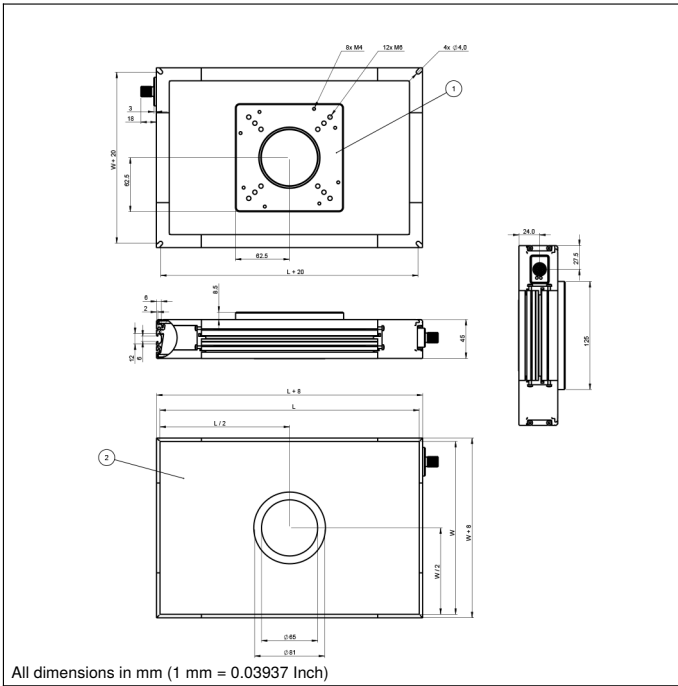

Ctrl. Panel

T16

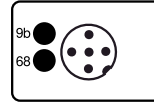

68 = supply voltage indicator
 9b = Strobe Mode Indicator

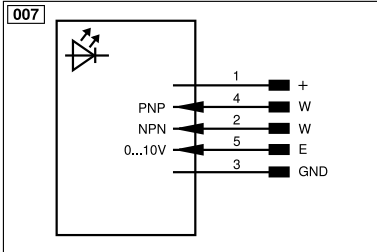

Legend			
+	Supply Voltage +	nc	Not connected
-	Supply Voltage 0 V	U	Test Input
~	Supply Voltage (AC Voltage)	Ü	Test Input inverted
A	Switching Output (NO)	W	Trigger Input
Ā	Switching Output (NC)	W-	Ground for the Trigger Input
V	Contamination/Error Output (NO)	O	Analog Output
ȳ	Contamination/Error Output (NC)	O-	Ground for the Analog Output
E	Input (analog or digital)	BZ	Block Discharge
T	Teach Input	Amv	Valve Output
Z	Time Delay (activation)	a	Valve Control Output +
S	Shielding	b	Valve Control Output 0 V
RxD	Interface Receive Path	SY	Synchronization
TxD	Interface Send Path	SY-	Ground for the Synchronization
RDY	Ready	E+	Receiver-Line
GND	Ground	S+	Emitter-Line
CL	Clock	±	Grounding
E/A	Output/Input programmable	SnR	Switching Distance Reduction
IO-Link		Rx+/-	Ethernet Receive Path
PoE	Power over Ethernet	Tx+/-	Ethernet Send Path
IN	Safety Input	Bus	Interfaces-Bus A(+)/B(-)
OSSD	Safety Output	La	Emitted Light disengageable
Signal	Signal Output	Mag	Magnet activation
BI_D+/-	Ethernet Gigabit bidirect. data line (A-D)	RES	Input confirmation
ENo RS422	Encoder 0-pulse 0/0 (TTL)	EDM	Contactor Monitoring
PT	Platinum measuring resistor	ENARs422	Encoder A/Ā (TTL)
		ENBRs422	Encoder B/Ī (TTL)
		ENA	Encoder A
		ENb	Encoder B
		AMIN	Digital output MIN
		AMAX	Digital output MAX
		Aok	Digital output OK
		SY In	Synchronization In
		SY OUT	Synchronization OUT
		OLT	Brightness output
		M	Maintenance
		rsv	Reserved
		Wire Colors according to DIN IEC 60757	
		BK	Black
		BN	Brown
		RD	Red
		OG	Orange
		YE	Yellow
		GN	Green
		BU	Blue
		VT	Violet
		GY	Grey
		WH	White
		PK	Pink
		GNYE	Green/Yellow