

Model TR3 - Heavy Duty Tru-Trac™



Features

- Heavy Duty Encoder And Measuring Wheel Solution Integrated Into One Industrial Strength Unit
- Spring Loaded Torsion Arm Makes Wheel Pressure Adjustments A Snap
- Easily Installed In A Vertical, Horizontal, or Upside-Down Orientation
- Operates Over A Variety Of Surfaces At Speeds Up To 3000 Feet Per Minute
- Integrated Module Simplifies Your System Design, Reducing Cost
- IP67 Sealing Available

The TR3 Heavy Duty Tru-Trac™ is an integrated encoder and spring loaded measuring wheel assembly specifically designed for the demands of heavy industrial environments. Built on EPC's proven Tru-Trac™ technology, the Model TR3 is a versatile solution for tracking velocity, position or distance over a wide variety of surfaces in almost any industrial application. The spring loaded torsion arm provides a simple-to-adjust torsion load, allowing the Model TR3 to be mounted in any orientation, even upside-down. The Model TR3 housing is an all-metal work horse and features sealing up to IP67 to stand up to your toughest application environments at operating speeds of up to 3000 feet per minute. Just one look and it's easy to see that the Model TR3 Heavy Duty Tru-Trac™ is the ideal solution for countless demanding applications.

Common Applications

Lumber, Corrugated, Converting, Metal Roll Forming, Paper Monitoring, Glue Dispensing, Linear Material Monitoring, Conveyor Systems, Printing, Labeling, Mining, Construction

Model TR3 - Heavy Duty Tru-Trac™ Ordering Guide

Blue type indicates price adder options. Not all configuration combinations may be available. Contact Customer Service for details.

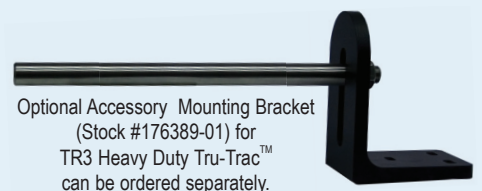
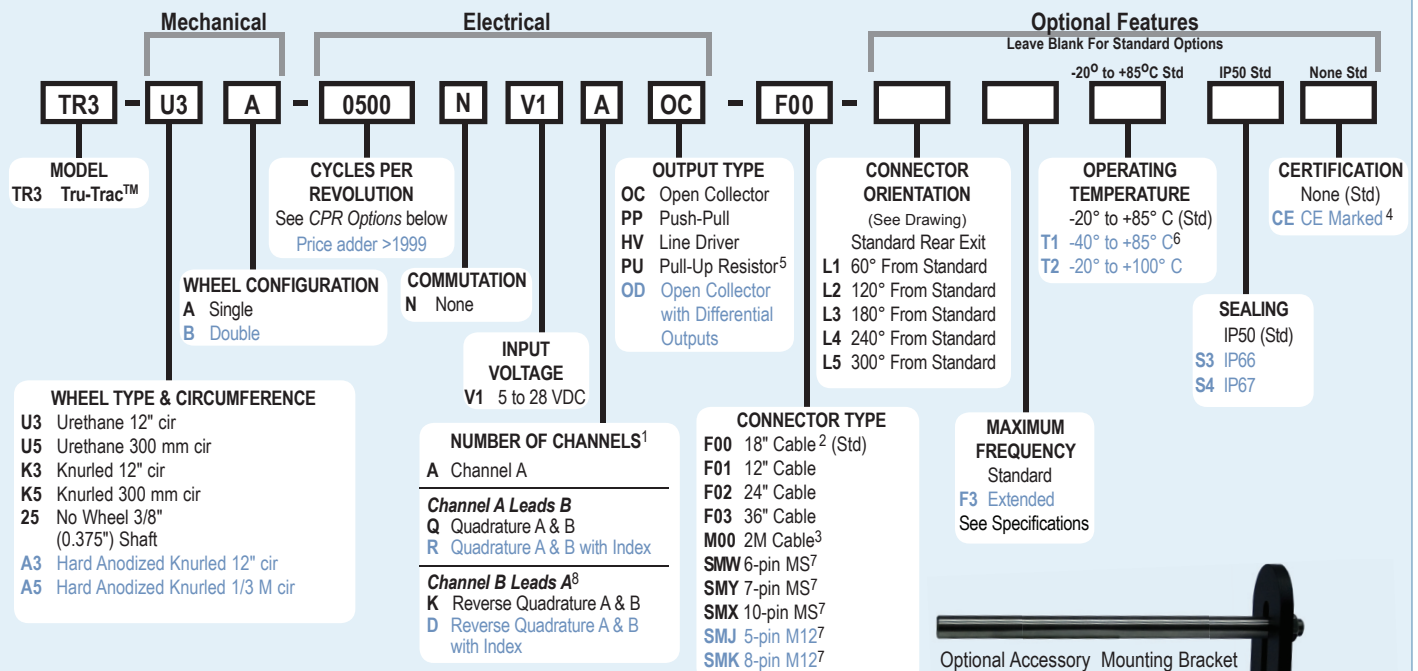

Model TR3 - Tru-Trac™ CPR Options

0001 thru 0189*	0198	0200	0250
0256	0300	0315	0400
0500	0512	0580	0750
0800	1000	1024	1125
1250	1500	1800	2000
2500	2540	3000	3600
4096	5000	6000	7200
10,000			8192

*Contact Customer Service For Availability

New CPR values are periodically added to those listed. Contact Customer Service to determine all currently available values. Special disk resolutions are available upon request and may be subject to a one-time NRE fee.

For specification assistance call
Customer Service at
1-800-366-5412

NOTES:

- 1 Contact Customer Service for non-standard index gating or phase relationship options.
- 2 For non-standard English cable lengths enter 'F' plus cable length expressed in feet. Example: F06 = 6 feet of cable. Frequency above 300 kHz standard cable lengths only.
- 3 For non-standard metric cable lengths enter 'M' plus cable length expressed in meters. Example: M06 = 6 meters of cable.
- 4 Please refer to **Technical Bulletin TB100: When to Choose the CE Option** at www.encoder.com.
- 5 With Input Voltage above 16 VDC, operating temperature is limited to 85° C.
- 6 Rated to -40° C during encoder operation. Storage and startup below -25° C not recommended.
- 7 Body Mount connector options only available with connector orientation L1 thru L5.
- 8 Reverse Quadrature not available with PU output type.

Model TR3 - Heavy Duty Tru-Trac™

Model TR3 Tru-Trac™ Specifications

Electrical

- Input Voltage.....4.75 to 28 VDC max for temperatures up to 85° C
4.75 to 24 VDC for temperatures between 85° C to 100° C
- Input Current..... 100 mA max (65 mA typical) with no output load
- Output Format..... Incremental- Two square waves in quadrature with channel A leading B for clockwise shaft rotation, as viewed from the wheel side. See *Waveform Diagrams* below.
- Output Types..... Open Collector- 20 mA max per channel
Push-Pull- 20 mA max per channel
Pull-Up- Open collector with 2.2K ohm Pull-Up 20mA max per channel
Line Driver- 20 mA max per channel (Meets RS 422 at 5 VDC supply)
- Index Once per revolution.
0190 to 10,000 CPR: Gated to output A
0001 to 0189 CPR: Ungated
See *Waveform Diagrams* below.
- Max. Frequency Standard Frequency Response is 200 kHz for CPR 1 to 2540
500 kHz for CPR 2541 to 5000
1 MHz for CPR 5001 to 10,000
Extended Frequency Response (optional) is 300 kHz for CPR 2000, 2048, 2500, and 2540
- Noise Immunity Tested to BS EN61000-6-2; BS EN50081-2; BS EN61000-4-2; BS EN61000-4-3; BS EN61000-4-6, BS EN500811
- Quadrature67.5° electrical or better is typical, 54°
- Edge Separation electrical minimum at temperatures > 99° C
- Waveform Symmetry...180°(±18°) electrical (single channel encoder)
- AccuracyWithin 0.017° mechanical or 1 arc-minute from true position. (for CPR>189)

Mechanical

- Max Linear Speed... 3000 FPM not to exceed a maximum shaft speed of 6000 RPM.
- Shaft Material Stainless Steel
- Shaft Size.....ø0.375"
- Radial Shaft Load .. Up to 10 lb max. Controlled by spring torsion feature
- Starting Torque..... 1.0 oz-in typical with IP50 seal
2.5 oz-in typical with IP66 seal and single wheel
4.0 oz-in typical with IP66 seal and dual wheel
7.0 oz-in typical with IP67 seal and single wheel
14.0 oz-in typical with IP67 seal and dual wheel
- Electrical Conn..... 18" cable (foil and braid shield, 24 AWG conductors)
6-, 7-, or 10-pin MS style, 5- or 8-pin M12 (12mm)
- Mounting5/8" diameter thru hole with clamp
- Housing Powder coated aluminum
- Wheel Width..... 3/4" standard
- Weight2.5 lb typical with single wheel
3.0 lb typical with dual wheel

Environmental

- Operating Temp.....-20° to +85° C for standard models
-40° to +85° C for low temperature option
-20° to +100° C for high temperature option
- Storage Temp.....-25° to +85° C
- Humidity98% RH non-condensing
- Vibration..... 10 g @ 58 to 500 Hz
- Shock80 g @ 11 ms duration
- Sealing IP50 standard; IP66 or IP67 optional

Model TR3 - Heavy Duty Tru-Trac™

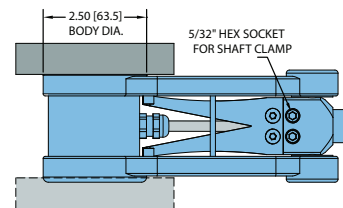
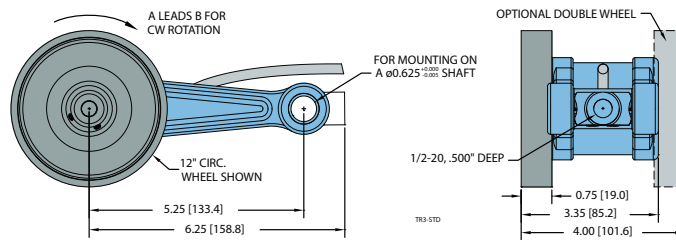

Model TR3 Mounting Bracket (Order #176389-01)

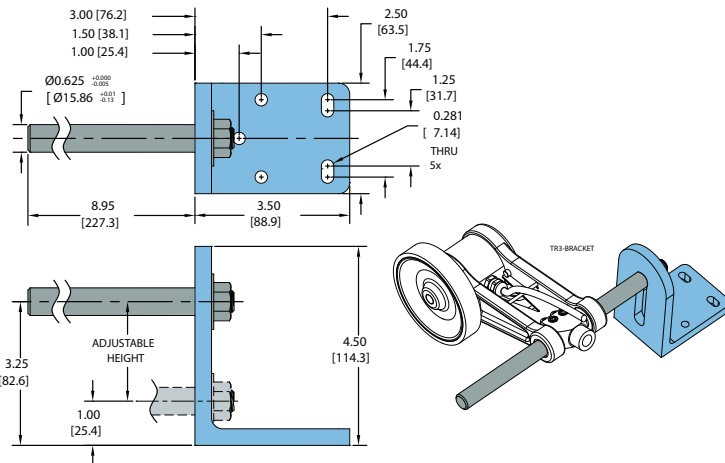

Model TR3 - Heavy Duty Tru-Trac™

Model TR3 Double Wheel Pivot (Order #176391-01)

ALLOWS UNIT TO ROTATE FREELY TO MAINTAIN EQUAL PRESSURE ON BOTH WHEELS, ACCOMODATING UNEVEN/ ANGLED SURFACES AND MOUNTING MISALIGNMENT

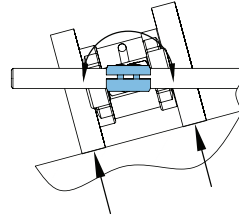
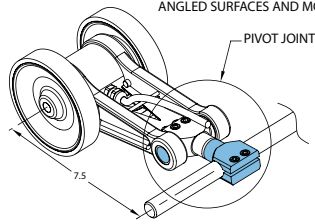

Model TR3 Connector Options

Connector Orientation

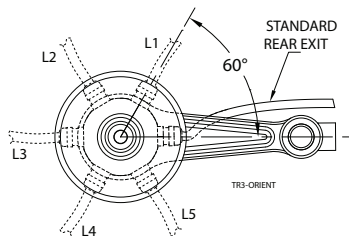

Wiring Table

Function	Gland Cable Wire Color ¹	5-pin M12 ²	8-pin M12 ²	10-pin MS	7-pin MS HV, OD	7-pin MS PU, PP, OC	6-pin MS PU, PP, OC
Com	Black	3	7	F	F	F	A,F
+VDC	White	1	2	D	D	D	B
A	Brown	4	1	A	A	A	D
A'	Yellow	----	3	H	C	----	----
B	Red	2	4	B	B	B	E
B'	Green	----	5	I	E	----	----
Z	Orange	5	6	C	----	C	C
Z'	Blue	----	8	J	----	----	----
Case	----	----	----	G	G	G	----
Shield	Bare ¹	----	----	----	----	----	----

¹CE Option: Cable shield (bare wire) is connected to internal case.
²CE Option: Read Technical Bulletin TB111.

Connector Pinouts

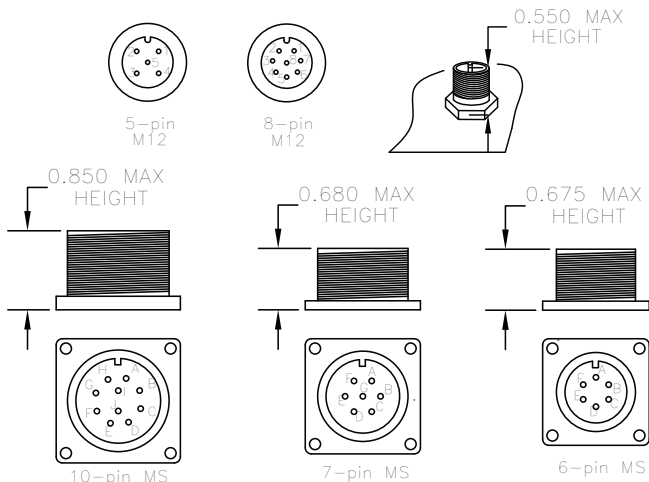

Waveform Diagram

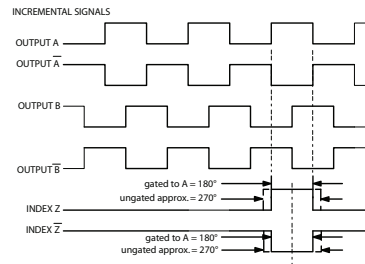

Clockwise rotation as viewed from the single wheel side.
 Note: All degree references are electrical degrees.
 Waveform shown with optional complementary signals A, B, Z for HV and OD outputs only.