

Model 958



Features

- European Size 58 (58 mm) Package
- Resolutions Up To 12 Bit (4096 PPR equivalent)
- Incorporates Opto-ASIC Technology
- Industrial Grade, Heavy Duty Housing
- Wide Range of Operating Voltages (4.75 to 26 VDC)

The Model 958 Single Turn Absolute Accu-Coder™ is ideal for a wide variety of industrial applications requiring an encoder with European Size 58 (58 mm) mounting and absolute positioning output. A rugged, industrial grade housing allows the Model 958 to be used in a wide variety of applications calling for a reliable, heavy-duty encoder. In addition, its innovative Opto-ASIC circuitry, coupled with its digital output, make it an excellent choice in those applications plagued by unusually high levels of electrical noise. Available with a choice of either type 20 or type 26 servo mounting, and a variety of connector and cabling options, the Model 958 is easily designed into a variety of applications. The Model 958 can also be ordered with stainless steel housing, heavy duty bearings, and an IP66 seal. (Contact a friendly EPC sales representative for more information). With so many options that make the Model 958 ultra-durable, this absolute encoder can tolerate the worst environments!

Common Applications

Machine Tools, Robotics, Telescopes, Antennas, Rotary & X-Y Positioning Tables, Medical Scanners

Model 958 Ordering Guide

Blue type indicates price adder options. Not all configuration combinations may be available. Contact Customer Service for details.

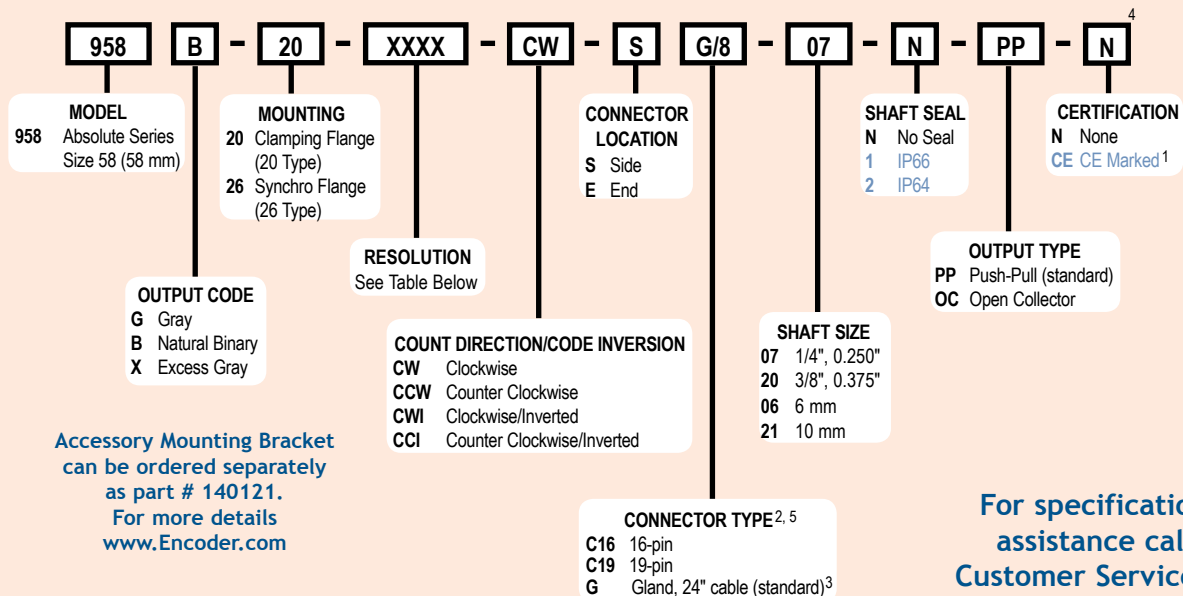

Model 958 Resolution Table

Output Code	Counts Per Resolution						
Gray Code	0256	0512	1024	2048	4096		
Natural Binary	0250	0256	0360	0500	0512	0720	1000
	1024	1440	2000	2048	2880	4000	4096
Excess Gray	0180	0250	0360	0500	0720	1000	1440
	2000	2880	4000				

*Contact Customer Service for availability.

NOTES:

- 1 Please refer to **Technical Bulletin TB100: When to Choose the CE Option** at www.encoder.com. Contact Customer Service for availability.
- 2 For additional connector styles please contact Customer Service.
- 3 Standard cable length is 24". For non-standard cable lengths, add a forward slash (/) plus cable length expressed in feet. Example: G/6 = 6 feet of cable.
- 4 Also available in stainless steel housing. Contact Customer Service for details.
- 5 For mating connectors, cables, and cordsets, please see www.encoder.com.

Model 958

Model 958 Specifications

Electrical

Input Voltage.....4.75 to 26 VDC max
 Regulation.....100 mV peak-to-peak, max ripple at 0 to 100 kHz
 Input Current.....100 mA max with no external load
 Output Format.....Absolute- Parallel Outputs
 Output Type.....Open Collector- 20 mA max per channel
 Push-Pull- 20 mA max per channel
 Code.....Gray Code, Natural Binary Code, Excess Gray Code
 Max Frequency.....50 kHz (LSB)
 Rise Time.....Less than 1 microsecond
 Resolution.....Up to 12 bit
 Accuracy.....+1/2 LSB

Control

Directional Control....Field selectable for increasing counts (CW or CCW)

Mechanical

Max Shaft Speed.....6000 RPM continuous
 Shaft Size.....0.250", 0.375", 6 mm, 10 mm
 Radial Shaft Load.....27 lb max
 Axial Shaft Load.....27 lb max
 Starting Torque.....1.0 oz-in typical for no seal
 2.0 oz-in with IP64 shaft seal
 Max Acceleration.....1 x 10⁵ rad/sec²
 Electrical Conn.....Gland with 24" cable (braid shield, 30 AWG conductors), 16-, 19-pin
 Housing.....Aluminum
 Mounting.....European Standard Clamping Flange (20 Type) and Synchro Flange (26 Type)
 Weight.....22 oz typical

Environmental

Operating Temp.....0° to 70° C
 Storage Temp.....-20° to +85° C
 Humidity.....98% RH non-condensing
 Vibration.....10 g @ 58 to 500 Hz
 Shock.....20 g @ 11 ms duration
 Sealing.....IP54 (standard)
 IP64, or IP66 (NEMA 13 and 4) optional

Model 958 Clamping Flange 20 Type (20)

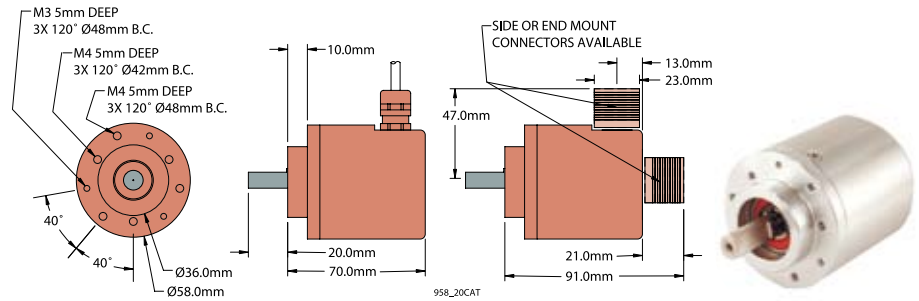

Model 958 Synchro Flange 26 Type (26)

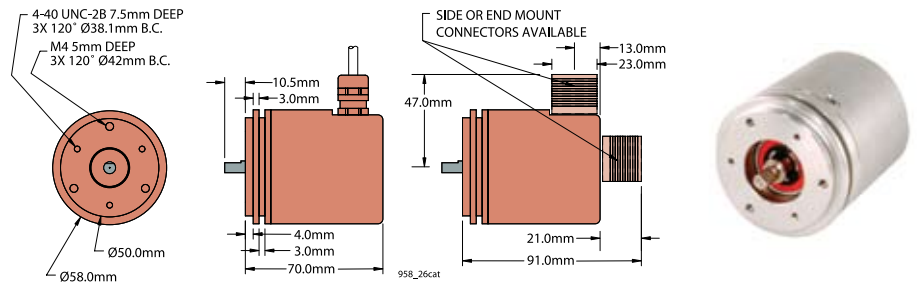

All dimensions are in millimeters with a tolerance of ±0.17 mm unless otherwise specified

Wiring Table

Function	19-PIN	16-PIN	Gland Cable or Mating Conn.	NOTES:
	KPT02E14-19P	Pin	Wire Color	
S1 MSB	A	3	Brown	* Only available with 8-bit resolution encoders ** Where Fitted *** Direction Control- Standard is CW increasing when viewed from the shaft end. Direction pin is pulled high normally to 5V internally. Direction pin must be pulled low (GND, Common) to reverse count direction. Applied voltage to direction pin should not exceed 5V.
S2	B	5	White	
S3	C	6	Green	
S4	D	7	Orange	
S5	E	8	Blue	
S6	F	9	Violet	
S7	G	10	Gray	
S8 LSB 8-bit	H	11	Pink	
S9 LSB 9-bit	J	12	Red/Green	
S10 LSB 10-bit	K	13	Red/Yellow	
S11 LSB 11-bit	L	14	Turquoise	
S12 LSB 12-bit	M	15	Yellow	
Direction***	R	4	Red/Blue	
Case Ground	S	16	Drain/Screen	
0V Common	T	1	Black	
Special**	U	—	White/Red	
+VDC	V	2	Red	