

Dress Pack

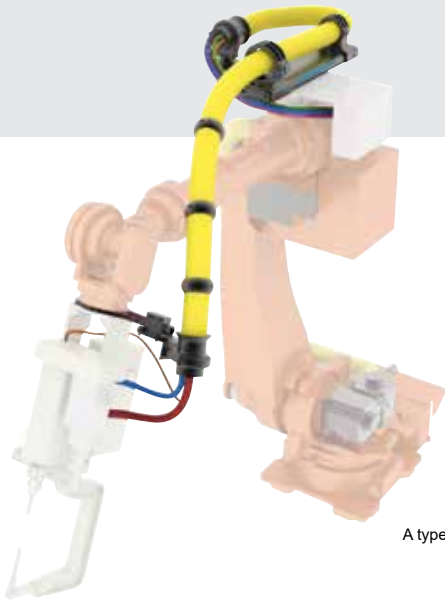

A type



B type

Dress Pack (A Type)

Ordering Information

ROBOWAY - 70 - B - A

①

① Size	36, 48, 56, 70
Components	RW(1set), PAM(CPS FLEX 5m), RKTP(4pcs), RKS(2pcs), RKC(2pcs), RKSC(2pcs), RKR(1pcs), VCG(2pcs), RCS(1pcs),

Dress Pack (B Type)

Ordering Information

ROBOWAY - 48 - B - B

①

① Size	48,56,70
Components	PAM(CPS FLEX 5m), RKTP(4pcs), RKS(3pcs), RKC(3pcs), RKSC(2pcs), RKR(1pcs), VCG(2pcs), RCS(1pcs), RPS(1pcs), RBP(1pcs)

Retractor

Ordering Information

RW - 48 . 400 L : 10 ST

①

②

① Size	② L Stroke	A Bolt hole width	B Width	C Bolt hole width	D Length	E Height
36	300/400/	30	96	L+170	L+202	137
48	500/600/	30	96	L+170	L+202	137
56	350/450/	40	150	L+215.5	L+249	192
70	550/650	40	150	L+215.5	L+249	192

Parts for B Type



RPS
(Pillar Support)



RBP
(Bed Plate)



RCS
(Column Support)

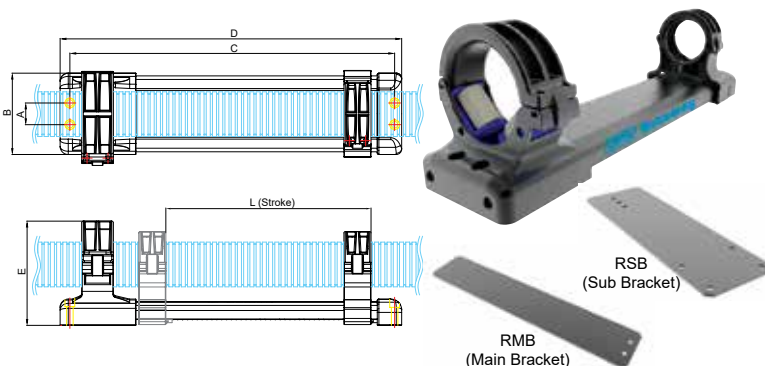

RMB
(Main Bracket)

RSB
(Sub Bracket)

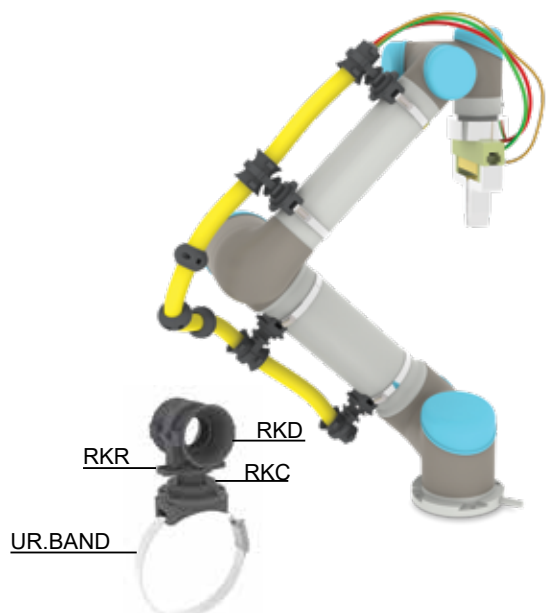

Dress Pack of Universal Robot

Part name	Robot Descriptions to be applied	Kit components
DP-UR3-22	UR3 robot type, Ø54 & Ø66 size of robot arm, Max. 3kg carried	UR3-054-22/28 (2pcs), UR3-066-22/28 (2pcs), PAR(PAM)22/28 (2m), SILICON PAD
DP-UR3-28		
DP-UR5-22	UR5 robot type, Ø75 & Ø86 size of robot arm, Max. 5kg carried	UR5-075-22/28 (2pcs), UR5-086-22/28 (2pcs), PAR(PAM)22/28 (2m), SILICON PAD
DP-UR5-28		
DP-UR10-22	UR10 robot type, Ø86 & Ø108 size of robot arm, Max. 10kg carried	UR10-086-22/28 (2pcs), UR10-108-22/28 (2pcs), PAR(PAM)22/28 (2m), SILICON PAD
DP-UR10-28		

UR. Band



Part name	Application for Robot type & Conduit size		
	Robot type	Robot arm type	Conduit size(mm)
UR3-054-22	UR3	Far arm(Ø54) from the base	22
UR3-054-28			28
UR3-066-22		Close arm(Ø66) from the base	22
UR3-066-28			28
UR5-075-22	UR5	Far arm(Ø75) from the base	22
UR5-075-28			28
UR5-086-22		Close arm (Ø86) from the base	22
UR5-086-28			28
UR10-086-22	UR10	Far arm(Ø86) from the base	22
UR10-086-28			28
UR10-108-22		Close arm (Ø108) from the base	22
UR10-108-28			28

Component Parts

Ordering Information

RKC - 70 : 10 EA

① ②

	① Part name	② Conduit Size	Dimension				description
			Width	Height	Length	Outer Diameter	
	RKTP (Abrasion protector)	22 28 36 48 56 70	28.0 30.0 30.0 30.0 40.0 40.0	46.4 53.0 62.0 80.0 93.2 108.0	-	46.4 53.0 62.0 80.0 93.2 108.0	Made of reinforced polyamide 6. Protect abrasion and damage of tube when tube bumps on robot arm.
	RKTC (Abrasion protector)	48 56 70	50.0 60.0 60.0	78.0 90.2 105	-	78.0 90.2 105	If robot tube got damaged such as cut or stretched condition, you don't need to replace total tube by using RKTC as it can cover damaged area.
	RKC (Bracket)	22 28 36 48 56 70	30.0 30.0 45.0 49.5 40.0 40.0	50.0 59.5 88.3 105.0 138.1 145.5	49.0 58.8 90.2 128.2 150.1 164.9	45.0 53.5 76.0 94.0 116.2 131.0	Tube clamp in combination with RKS+RKRC or RKD+RKRC to holds tube's movement while robot operates.
	RKS (Tube Ball Joint)	22 28 36 48 56 70	50.0 60.0 100.3 89 102 102	23.0 27.0 80.5 92.3 105.3 120.1	23.0 27.0 80.5 92.3 105.3 120.1	23.0 27.0 80.5 92.3 105.3 120.1	Tube ball joint to strengthen tube's flexibility and release tube's tension loaded by robot operation.
	RKD (Ball Joint Sleeve)	22 28 36	40.0 63.5 120.0	22.0 30.0 83.0	22.0 30.0 83.0	22.0 30.0 83.0	Tube ball joint, however, its shape is a little bit different as ball joint direction is bidirectional unlike RKS.
	RKSC (Strain Relief Insert)	22 28 36 48 56 70	10.5 13.0 20.6 22.0 26.0 26.0	29.5 34.5 44.6 67.5 81.2 96.0	-	29.5 34.5 44.6 67.5 81.2 96.0	22~36 of RKSC : It clamp for VCG. 48~70 of RKSC : It clamp for Tube and RKS.
	RKR (swivel plate)	22 28 36 48 56 70	43.0 55.0 98.0 98.0 98.0 98.0	18.5 23.0 42.0 42.0 42.0 42.0	-	43.0 55.0 98.0 98.0 98.0 98.0	RKR in combination with RKC is to release tube's tension and fatigue as it can rotate with robot-arm movement.
	VCG (Cable star)	22 28 36 48 56 70	10.5 13.0 20.6 24.0 34.0 34.0	25.5 30.5 40.6 62.5 75.8 90.0	-	25.5 30.5 40.6 62.5 75.8 90.0	Clamp for robot cables/hoses at end position of tube.

Tower Lights

Beacon Lights

LED Indicators Pilot Lamps

Buzzer Alarms

Pushbutton Switches

Limit Switches

Foot Switches

SSR

Relay & Sockets

Relay Terminal Blocks

Terminal Blocks

Fuse Holders

Enclosures