



2/2 way ball valve with electric rotary actuator, ball valve in plastic, DN10-50

- Suitable for aggressive media
- High flow rate value
- Actuator with adjustable limit switches
- Visual position indicator
- Safe blocked union nuts with Dual Block® Technology¹
- Multivoltage

The electric ball valve Type 8804 consists of an electrical rotary actuator and a 2/2 or 3/2 way ball valve made of plastic. Different housings and materials are available for various applications. The rotary actuator is compactly built. It can be used also as single device for the operation of other control elements (see datasheet Type 3003).

Special features

The ball valves are equipped with the so-called Dual Block® Technology. This system allows you to lock the union nuts in the preset position. It prevents them separating during operation.

Heat resistor and torque limiter are standard. The body is made of low inflammable material, classified acc. to UL 94 V0.

Technical data	
Body material	PVC-U, (PP, PVDF, PVC-C on request)
Seal material	PTFE/EPDM, (PTFE/FKM)
Media	Gaseous and liquid media, which do not attack the housing and sealing materials
Media temperature	(see diagram Pg. 3)
PVC-U	0 to +60 °C
PP	+10 to +80 °C
PVDF	0 to +120 °C
Ambient temperature	-10 to +55 °C
Port connections	
PVC-U (PP, PVDF on request)	True union (weld end coupling)
Operating pressure	0-10 bar; 0-16 bar
Connection between actuator and ball valve	Flange acc. to ISO 5211
Operating voltage	15-30 V AC 50/60 Hz / 12-48 V DC 100-240 V AC 50/60 Hz / 100-350 V DC
Voltage tolerance	± 10%; for 12 to 48 V DC the operating voltage should not go below 11.5 V
Duty rating	acc. to IEC34 S4 = 50%
Electrical connection	Cable Plug acc. to EN175301-803 (supply voltage) Cable glands ISO M20
Protection class	IP66 with cable plug installed
Rotation angle	90° (± 5°)
Rotation time	see ordering chart
Limit switches	4 adjustable (2 for motor and 2 additional for feedback) max. 250 V AC/1.5 A max. 250 V AC/1.5 A
Material (Actuator)	
Cover/Body	Nylon/PA 6.6
Axis/Screws	Stainless steel
gearbox	stainless steel and PC
Installation	Don't mount the actuator upside down

¹ Dual Block® Technology is a registered trademark of FIP – Formatura Iniezione Polimeri S.p.A

Electrical connection

On/Off Version

3 point mode

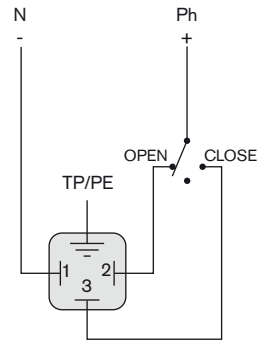

on/off mode

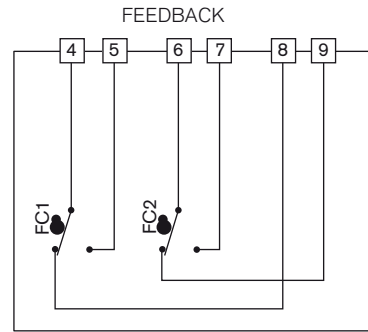
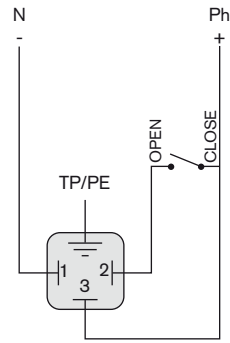

Symbol	Designation
FCO	Open limit switch
FCF	Close limit switch
FC1	Auxiliary 1 limit switch
FC2	Auxiliary 2 limit switch

Version with analog signal input

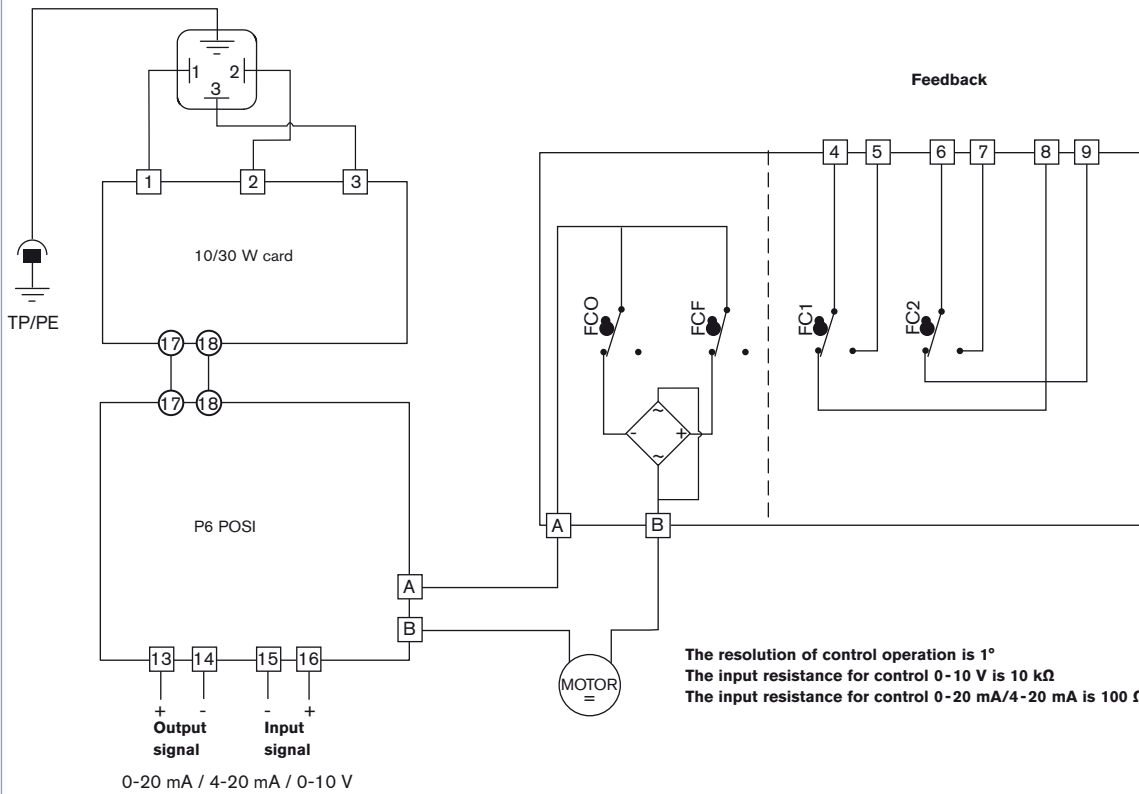
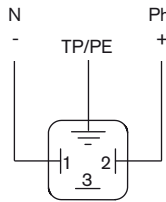

Pressure Temperature Chart

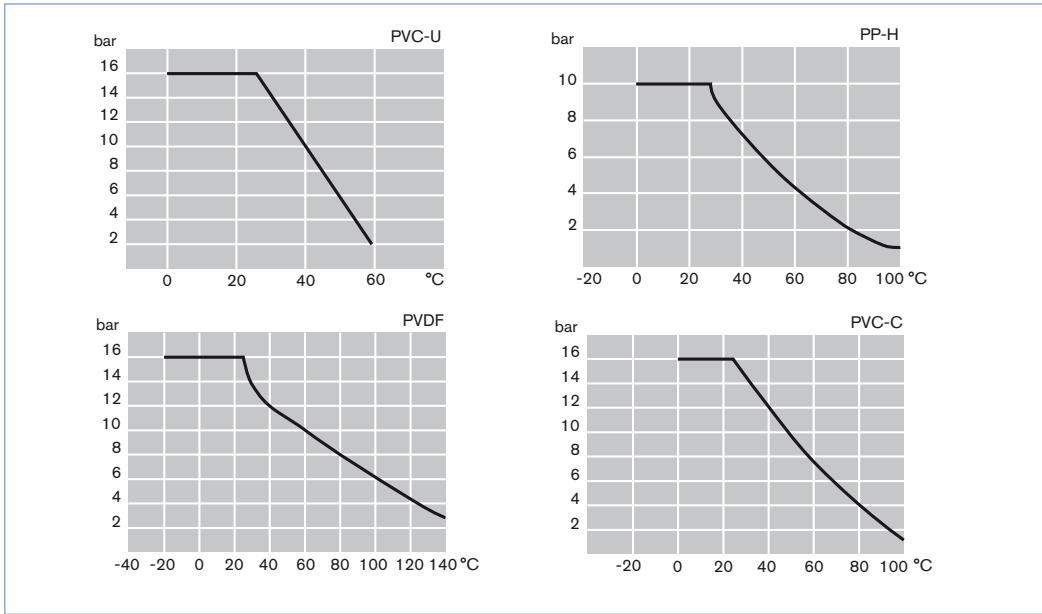

Dimensions [mm]

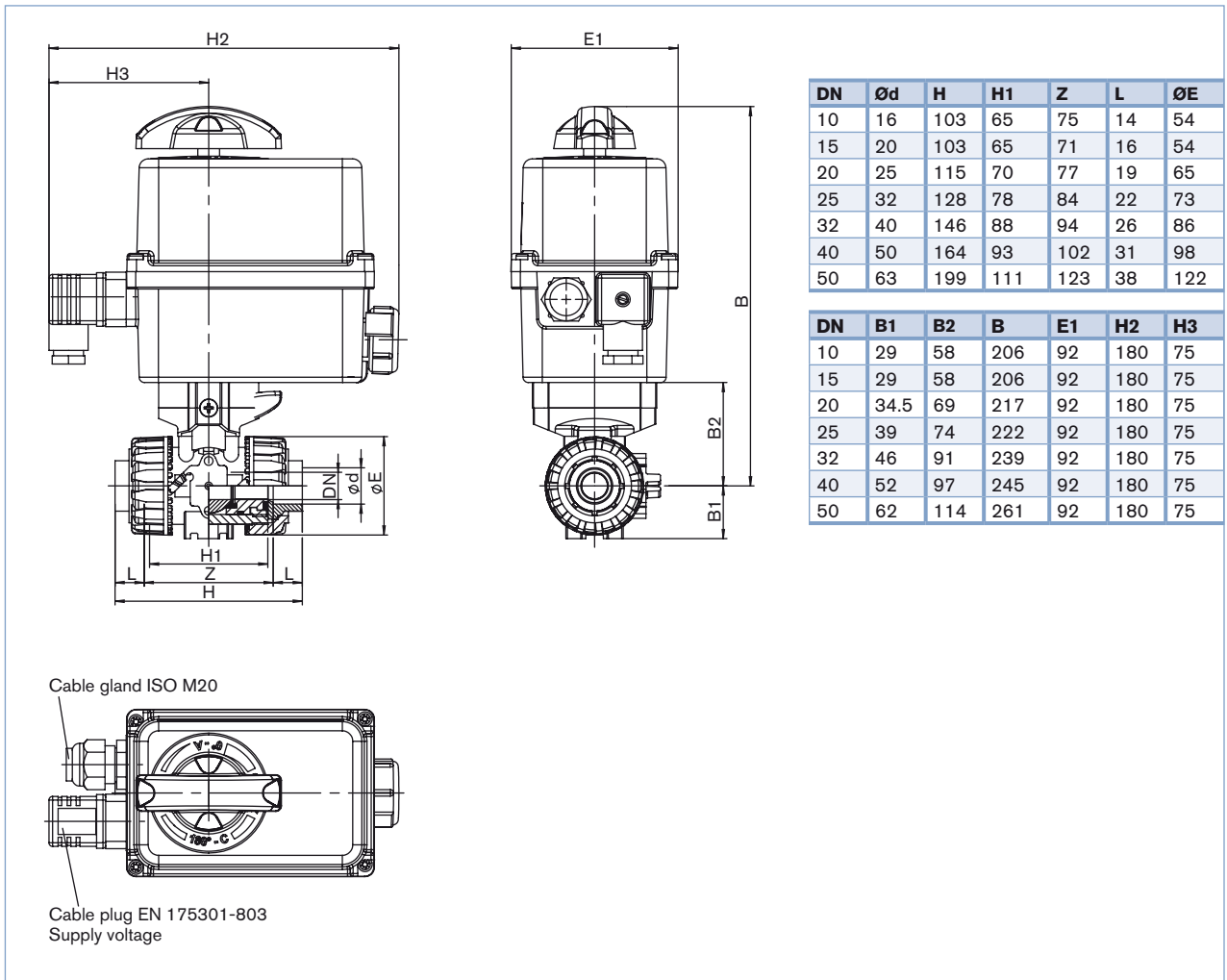

Ordering chart (further versions on request)

Orifice (mm)	Port connection Ø (mm)	K _v value water (m ³ /h)	Pressure range PVC-U, PVDF (bar)	Pressure range PP (bar)	Rotation time for 90° (s)	Actuator (Nm)	Voltage*	Article no. True union PVC-U
Seal material PTFE/EPDM								
10	16	4.8	0-16	0-10	12	20	100-240 V AC 50/60 Hz 100-350 V DC	226440
15	20	12	0-16	0-10	12	20		226453
20	25	23	0-16	0-10	12	20		226454
25	32	46	0-16	0-10	12	20		226455
32	40	66	0-16	0-10	12	20		226456
40	50	105	0-16	0-10	12	20		226457
50	63	204	0-16	0-10	12	20		226178
10	16	4.8	0-16	0-10	12	20	15-30 V AC 50/60 Hz 12-48 V DC	226459
15	20	12	0-16	0-10	12	20		226460
20	25	23	0-16	0-10	12	20		226461
25	32	46	0-16	0-10	12	20		226462
32	40	66	0-16	0-10	12	20		226463
40	50	105	0-16	0-10	12	20		226464
50	63	204	0-16	0-10	12	20		226465

* for 12 to 48 V DC the operating voltage should not go below 11.5 V

Further versions on request



Materials

Body: PVDF, PVC-C, PP
Seal material FKM on request



Additional

Positioner card with normal input signal 4-20 mA or 0-10 V
Feedback via Potentiometer or 4-20 mA analog signal
Slow rotation version
3-position actuator (90° or 180°)
Fail safe version
3/2 way

Accessories

Description	Article no.
Key for adjustment of limit switches	665296

Spacer plate and thread insert for mounting on control panel or wall on request.

Note
You can fill out the fields directly in the PDF file before printing out the form.

Ball valve and butterfly valve - Request for quotation

▶ Please fill out and send to your nearest Bürkert facility* with your inquiry or order

Company	Contact person
Customer No	Department
Address	Tel./Fax
Postcode/Town	E-mail

Quantity Required delivery date

Operating data

Pipeline DN PN

Pipe material

Process medium

Type of media Liquid Steam Gas

	Min	Standard	Max	Unit
Flow rate (Q, Q _N , W) ¹⁾	<input type="text"/>	<input type="text"/>	<input type="text"/>	<input type="text"/>
Media temperature	<input type="text"/>	<input type="text"/>	<input type="text"/>	<input type="text"/>
Operating pressure	<input type="text"/>	<input type="text"/>	<input type="text"/>	<input type="text"/>

¹⁾ Standard unit
Liquid Q = m³/h; Steam W = Kg/h; Gas Q_N = Nm³/h

Valve features

Type 2/2 way ball valve 3/2 way ball valve L-Boring 3/2 way ball valve T-Boring Butterfly valve

Body material Stainless⁴⁾ steel PVC-C PVC-U PP PVDF other

Seal material PTFE/EPDM²⁾ PTFE/FKM²⁾ EPDM³⁾ FKM³⁾ other

Nominal pressure PN

Orifice DN

Type of connection Flange True union Welded Int. thread Ext. thread Clamp

Standard connection ISO DIN ANSI JIS other

Pilot pressure min. max.

²⁾ for plastic ball valve ³⁾ for butterfly valves ⁴⁾ Stainless steel ball valve with PTFE seal material only

Mode of actuation

Manual

Pneumatic

Control function A: NC by spring action

Double-acting

Electric actuator

Function On/Off function Control actuator with analog signal input

Power supply 230 V AC 24 V AC 24 V DC other

To find your nearest Bürkert facility, click on the orange box → www.burkert.com

In case of special application conditions, please consult for advice.

Subject to alteration.
© Christian Bürkert GmbH & Co. KG

1803/10_EU-en_00891967

DTS 1000089995 EN Version: | Status: RL (released | freigegeben | valide) printed: 15.03.2018