

3/2 way and 2 × 3/2 way Solenoid Valve for pneumatics

- Compact design
- Single and manifold mounting
- Low power consumption
- Fast response times
- Second connection shut-off function

Type 6524 can be combined with...

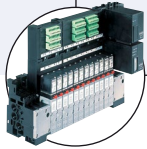

Type 8640
Valve island



Type 2031
Diaphragm valve

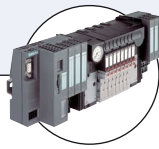

Type 8644
Valve island



Type 0044
Cylinder

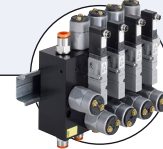

Type MKRS
Redundancy bloc

The Type 6524 consists of the pilot flipper solenoid valve Type 6144 and a pneumatic seat valve. The flipper principle allows switching of high pressures together with low power consumption and fast response times. All valves are equipped with manual override as a standard.

The 2 × 3/2 way valve version is the combination of two pilot flipper solenoid valves Type 6144 and a pneumatic seat valve.

The valve is also available with a second connection (pressed cable), whereby a safety-related shut-off function is realized

Technical data	3/2 way valve	2 × 3/2 way valve
Orifice	DN4.0	
Body material	PPS, PA	
Seal material	FKM, NBR	
Medium	Lubricated, oilfree, dry compressed air; neutral gases (5 µm filter recommended)	
Medium temperature	- 10 ... + 50 °C	
Ambient temperature	- 10 ... + 55 °C	
Manual override	Standard	
Port connection	Flange for MP11	
Pneumatic module	Type MP11 with M5, M7, push-in connection Ø 6 mm	
Voltage tolerance	± 10%	
Cycle rate	approx. 1000 c.p.m.	
Voltage	24 V DC *	
Nominal power	0.8 W	2 × 0.8 W
Duty cycle	Continuous operation (100% ED)	
Electrical connection on valve	Rectangular plug with 2 pin raster 5.08 mm	Rectangular plug with 3 pin raster 2.54 mm
Type of protection	IP40 with rectangular plug	
Protection class	3 acc. to VDE 0580	
Weight	20 g	40 g
Mounting	with 2 screws M2 x 20	with 2 screws M2 x 28
Installation	As required, preferably with actuator upright	

* 10% residual ripple allowed

Response times [ms]	Measurement acc. to ISO 12238
Opening	< 10 ms
Closing	< 10 ms

Dimensions [mm] 3/2 way solenoid valve - Standard version

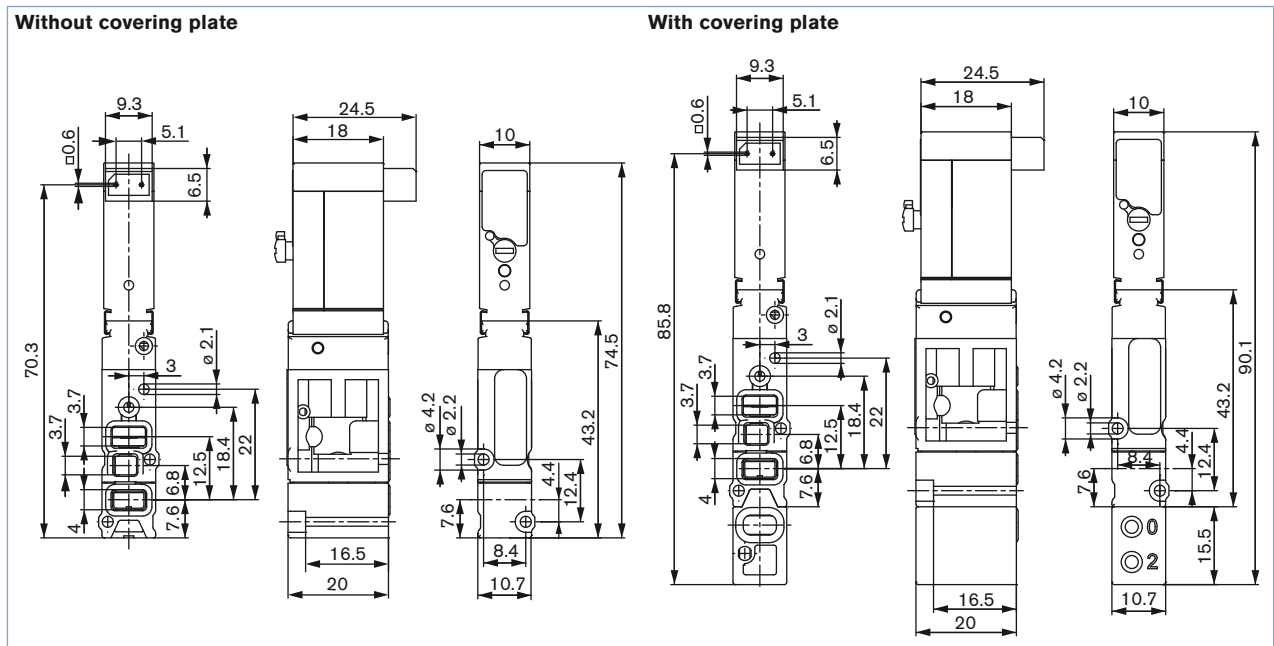

Sectional drawing 3/2 way solenoid valve - Standard version

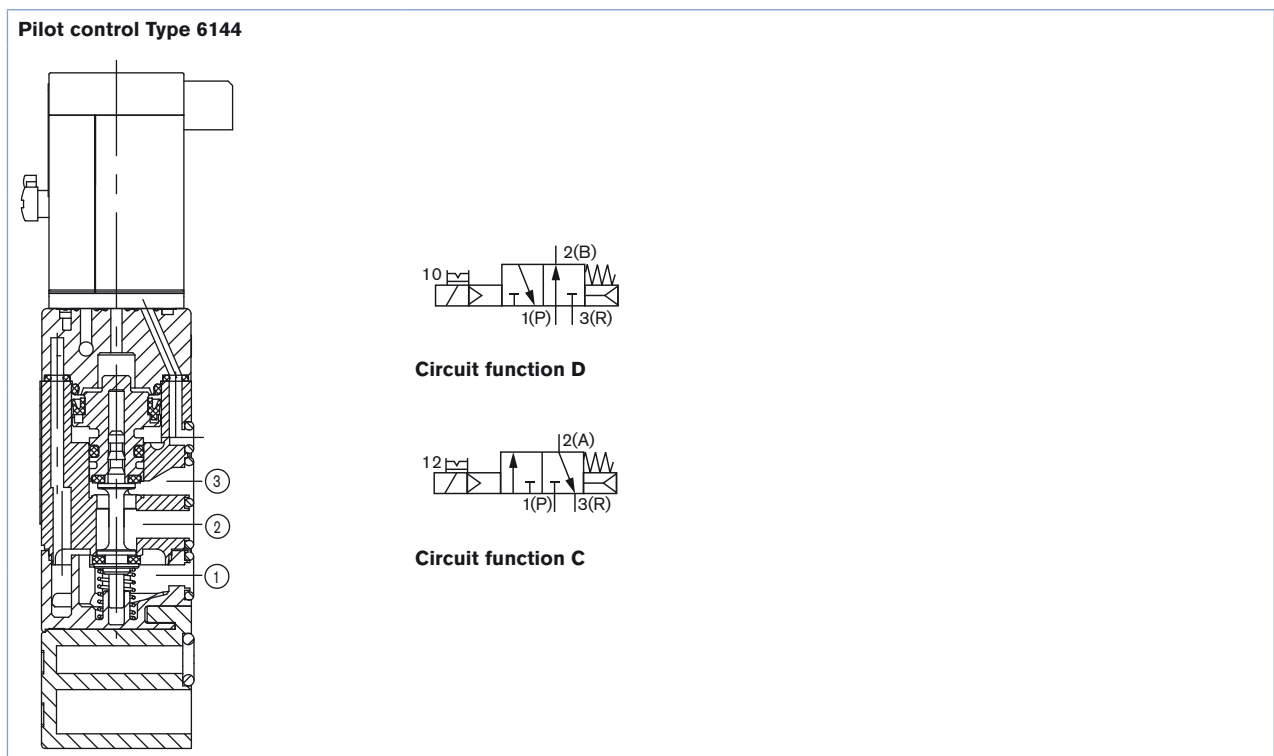

Dimensions [mm] 2 x 3/2 way solenoid valve - Standard version

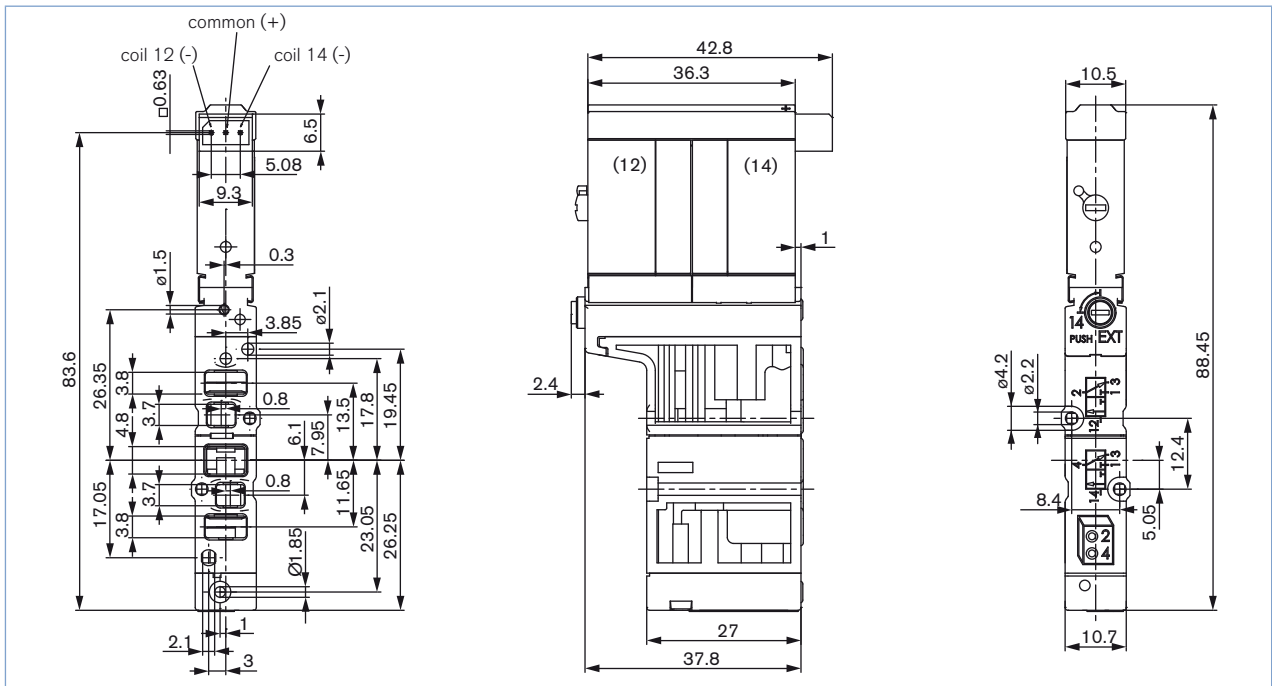

Sectional drawing 2 x 3/2 way solenoid valve - Standard version

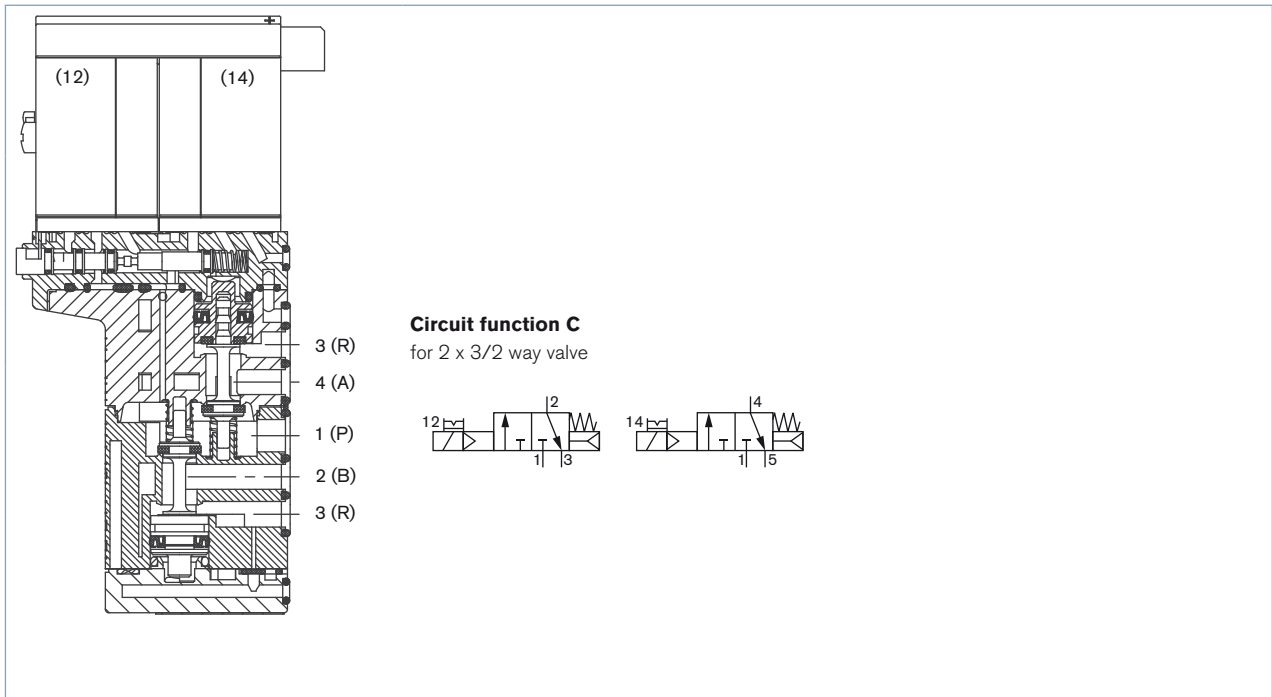

Dimensions [mm] 3/2 way solenoid valve - Second connection shut-off function

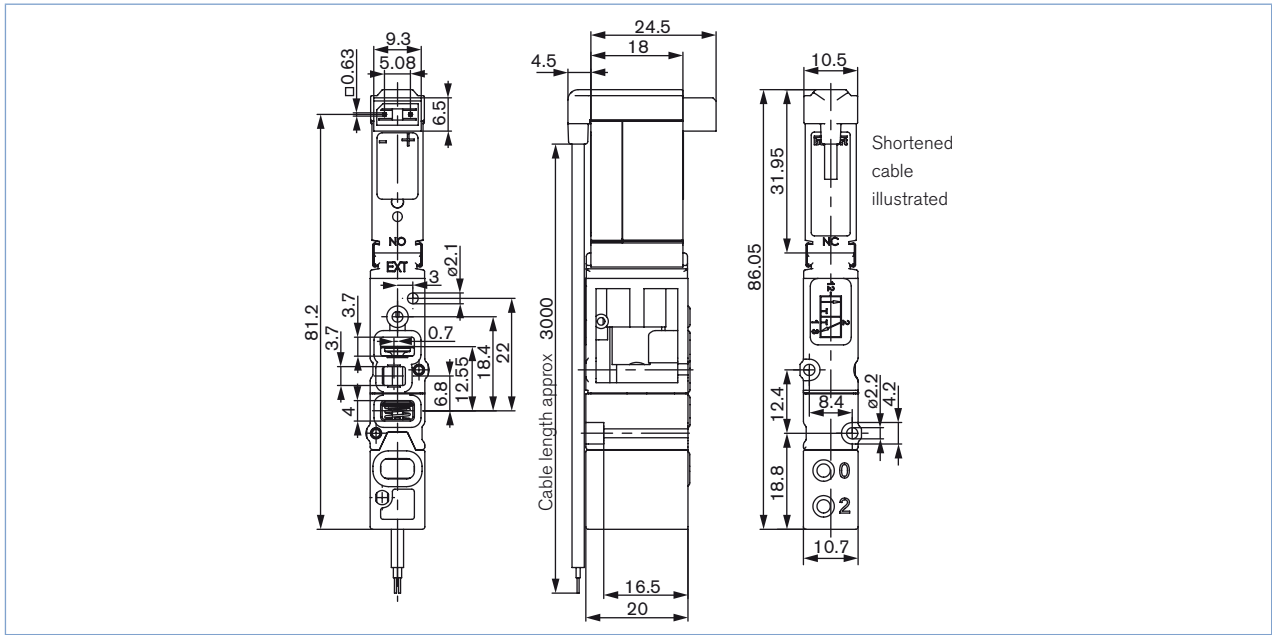



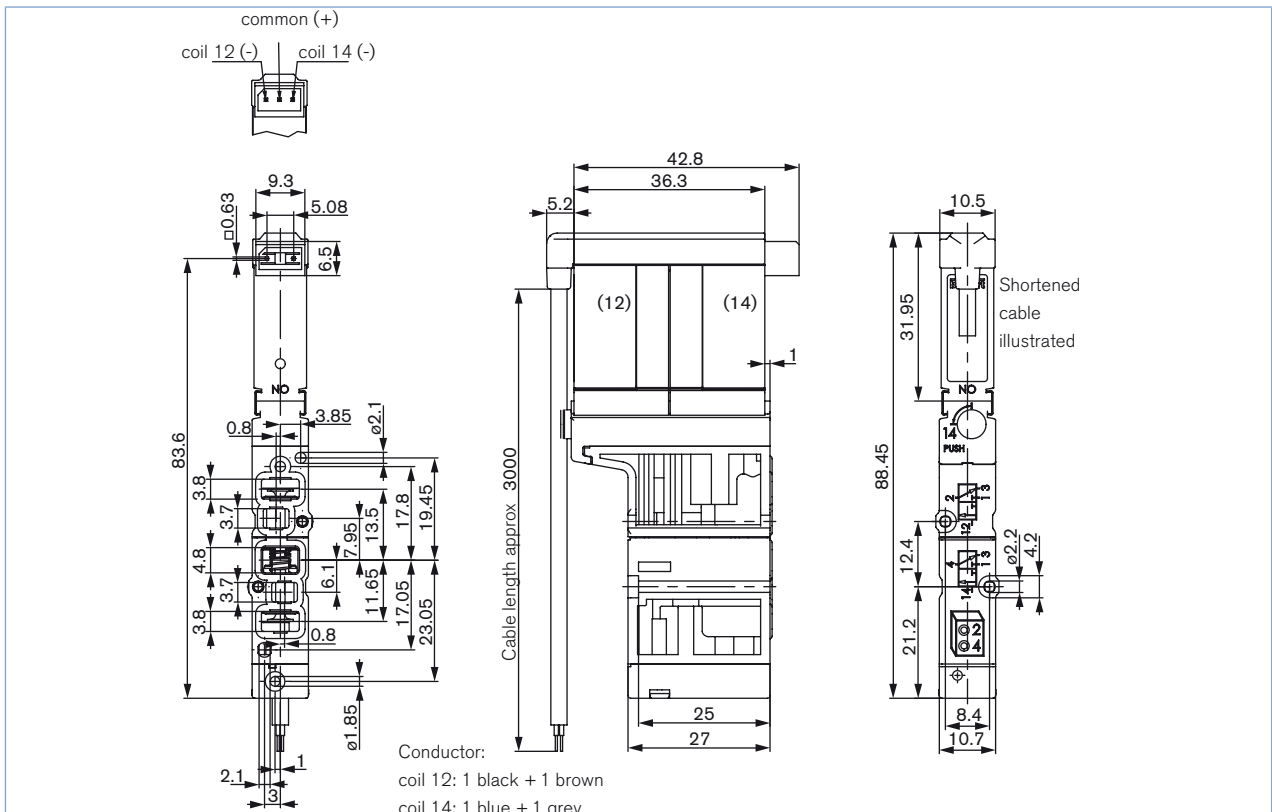



Dimensions [mm] 2 x 3/2 way solenoid valve - Second connection shut-off function

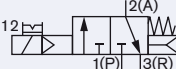



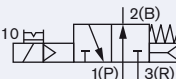

Ordering chart for valves - Standard version

3/2 way solenoid valve

Circuit function	Orifice [mm]	Q_{Nn} value air [l/min] ²⁾	Pressure range [bar] ³⁾	Voltage/frequency [V/Hz]	Article no.
C 3/2 way valve 	4	300	Vac...10 ¹⁾	24 V DC *	186258 
			1 ... 10	24 V DC *	186257 
			2.5 ... 10	24 V DC *	184043 
D 3/2 way valve 	4	300	2.5 ... 10	24 V DC *	184400 

* 10% residual ripple allowed

2 × 3/2 way solenoid valve



Circuit function	Orifice [mm]	Q_{Nn} value air [l/min] ²⁾	Pressure range [bar] ³⁾	Voltage/frequency [V/Hz]	Integrated power savings electronics	Article no.
C 2 × 3/2 way valve 	4	300	Vac...10 ¹⁾	24 V DC *	Yes ⁴⁾	186259 
			2.5 ... 10	24 V DC *	Yes ⁴⁾	186260 
			2.5 ... 10	24 V DC *	No	204710 

* 10% residual ripple allowed

¹⁾ Version with auxiliary pilot air²⁾ Measured at +20 °C, 6 bar pressure at valve inlet and 1 bar pressure difference³⁾ Measured as overpressure to the atmospheric pressure⁴⁾ Applicable on valve island 8640, AirLine system 8644 or valve blocks

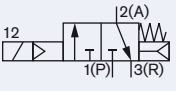

Ordering chart for valves - Second connection shut-off function

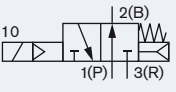
3/2 way solenoid valve, without manual override

Circuit function	Orifice [mm]	Q_{n0} value air [l/min] ²⁾	Pressure range [bar] ³⁾	Voltage/frequency [V/Hz]	Article no.
C 3/2 way valve 	4	300	Vac...10 ¹⁾	24 V DC *	On request
			1 ... 10	24 V DC *	On request
			2.5 ... 10	24 V DC *	285545 
D 3/2 way valve 	4	300	2.5 ... 10	24 V DC *	On request

* 10% residual ripple allowed

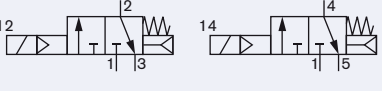



















2 × 3/2 way solenoid valve, without manual override

Circuit function	Orifice [mm]	Q_{n0} value air [l/min] ²⁾	Pressure range [bar] ³⁾	Voltage/frequency [V/Hz]	Integrated power savings electronics	Article no.
C 2 × 3/2 way valve 	4	300	Vac...10 ¹⁾	24 V DC *	Yes ⁴⁾	On request
			2.5 ... 10	24 V DC *	Yes ⁴⁾	285547 
			2.5 ... 10	24 V DC *	No	On request

* 10% residual ripple allowed

¹⁾ Version with auxiliary pilot air²⁾ Measured at +20 °C, 6 bar pressure at valve inlet and 1 bar pressure difference³⁾ Measured as overpressure to the atmospheric pressure⁴⁾ Applicable on valve island 8640, AirLine system 8644 or valve blocks

Ordering chart for accessories

Accessory	Version	Features	Article no.
Rectangular cable plug for 6524 single valve	Raster 5.08 mm	with 3 m cable 2-pins	133486 
		with 300 mm flying leads 2-pins	644068 
		with 2 single contacts	644067 
Covering plate for 5/2 way valve position	Complete	for 1 unused valve position	650373 
Covering plate for 2 x 3/2 way valve position		for 1 unused valve position	661092 
Pneumatic connector module	Left	G 1/4	144750 
		NPT 1/4	144751 
	Right	G 1/4	144753 
		NPT 1/4	144754 
Pneumatic basic module MP11, 2 valves wide	Push-in connection Ø 6 mm	without check valve	144903 
		without check valve for 2 x 3/2 way valve	170261 
		with check valve in R+S for 2 x 3/2 way valve	170266 
	Connection M7	without check valve	144905 
		without check valve for 2 x 3/2 way valve	170263 
		with check valve in R+S for 2 x 3/2 way valve	170276 
Pneumatic basic module MP11, 8 valves wide	Push-in connection Ø 6 mm	without check valve	144912 
		without check valve for 2 x 3/2 way valve	170279 
		with check valve in R+S for 2 x 3/2 way valve	170285 
	Connection M7	without check valve	144914 
		without check valve for 2 x 3/2 way valve	170282 
		with check valve in R+S for 2 x 3/2 way valve	170287 

To find your nearest Bürkert facility, click on the orange box → www.burkert.comIn case of special application conditions,
please consult for advice.Subject to alteration
© Christian Bürkert GmbH & Co. KG

1801/11_EU-en_00891919