

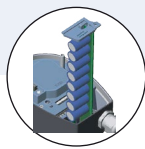

Type 3360 can be combined with...



Rugged Display
with operating buttons



SAFEPOS
energy-pack



Type 3361
for highest control
accuracy



Fieldbus



Electromotive process valve - 2 way angle-seat control valve

- good and fast control
- weather, impact and vibration resistant design
- easy cleaning by its design according hygienic demands
- position controller und process controller available

The innovative process controller Bürkert valve Type 3360 is the solution when it comes to control tasks under demanding operating conditions. The electromotive actuator with ball screw positions the control come with highest precision. A unique feature is its high positioning speed of 6 mm/s, that reacts quasi delay-free to process signals, and can be varied according to customer demands. Pressure variations or shocks in the medium aren't transferred to the valve position. If necessary, the safety position can be approached by an optional energy storage in case of power failure. Actuator and valve are adapted perfectly to each other with closed design and robust surface. This ensures the hygienic requirements of a fast and residue-free cleaning. Harsh environment are no problem for the Type 3360 because of the protection class IP65 / IP67 and its high impact and vibration resistance. Unrivalled cycle life and sealing integrity is guaranteed by the proven self adjusting spindle packing with exchangeable V-seals. The fieldbus suitable Type 3360 provides many helpful functions for process monitoring, valve diagnostics and predictive maintenance and thus offers the decisive advantage of a modern process automation.

Technical data	
K_{vs} values	5 ... 53 m ³ /h
Port size	DN15 ... DN50
Operating pressure	16 bar / 1600 kPa / 232 psi
Port connections	
thread	G, RC, NPT (EN ISO 228-1, ISO 7/1 / DIN EN 10226-2, ASME B 1.20.1)
weld ends	EN ISO 1127 / ISO 4200, DIN 11850 R2, ASME BPE, BS 4825-1, SMS 3008
clamp	ISO 2852, DIN 32676, ASME BPE, BS 4825
Medium	Neutral gases, water, alcohol, oils, fuel, hydraulic mediums, salt solution, alkali solutions, organic solvents, steam
Viscosity	max. 600 mm ² /s
Media temperature	-10...+185 °C (seat sealing steel/steel) -10...+185 °C (seat sealing PEEK/steel) -10...+130 °C (seat sealing PTFE/steel)
Ambient temperature	-25... +65 °C (without touch display) -25... +60 °C (with touch display) -25... +55 °C (with SAFEPOS energy storage) Note: Derating see temperature chart
Seat leakage acc. to IEC 534-4/EN 1349	Shut-off class III and IV for steel/steel Shut-off class VI for PTFE/steel and PEEK/steel
Safety position at power failure	with SAFEPOS energy-pack: opened, closed or free programmable without SAFEPOS energy-pack: blocked in last position
Power supply	24 V DC ± 10 % (max. residual ripple 10 %)
Closing time	2.3 ... 4.3 sec. (depending on stroke)
Travel speed	6 mm/s
Deadband (min.)	0.1 %
Duty cycle	100 %
Protection class	IP65 / IP67
Controller Type	Position controller or process controller

Technical data, continued

Analogue control	Setpoint: 0–20 mA, 4–20 mA, 0–5 V, 0–10 V actual value optional
Digital control (fieldbus)	EtherNet/IP, Modbus/TCP, PROFINET (optional)
Vibration, sinusoidal	5 g according to IEC 60068–2–6 Test Fc
Shock, mechanical	50 g according to IEC 60068–2–27 Test Ea
Approval and Conformity	EGV 1935/2004 (standard) FDA (optional) ATEX II Cat 3G/D / IECEx (optional) cULus Cert. No. 238179 (optional)
Ignition protection	II 3G Ex ec IIC T4 Gc II 3D Ex tc IIIC T135 °C Dc

Structure and function

The electromotive linear actuator consists of a brushless direct current motor, gears and a threaded spindle. The valve spindle, which is connected to the threaded spindle, transfers the force to the control cone. The electronic control system is actuated either via standard signals (analog) or via a field bus (digital). Available controller Types are a position controller or a process controller. Optionally there is the energy pack (SAFEPOS energy-pack) for the device. If the supply voltage fails, the energy pack supplies the actuator with the required energy to move the valves into the required position which can be adjusted via a menu.

The valve position can be manually changed in 2 ways. Either over an electrical manual control or over mechanical manual control, if no supply voltage applied. The device can be set and operated either via 2 capacitive buttons and 4 DIP switches or optionally on a display with touchscreen. There is also the option of setting the device via the bus Service interface and by using the PC software "Bürkert-Communicator".

The intelligent process valve Type 3360 offers the operator options for process monitoring, valve diagnostics and predictive maintenance. Internal measurements for the operating state are evaluated and, if issued as a warning or error message. This signal, for example, undue environmental and process conditions, functional deviations of components or the state of the energy accumulator. Internal measurements for operating state are evaluated and, possible a warning or error message is issued. This signal indicates, for example, bad environmental and process conditions, functional deviations of components or the state of the energy accumulator.

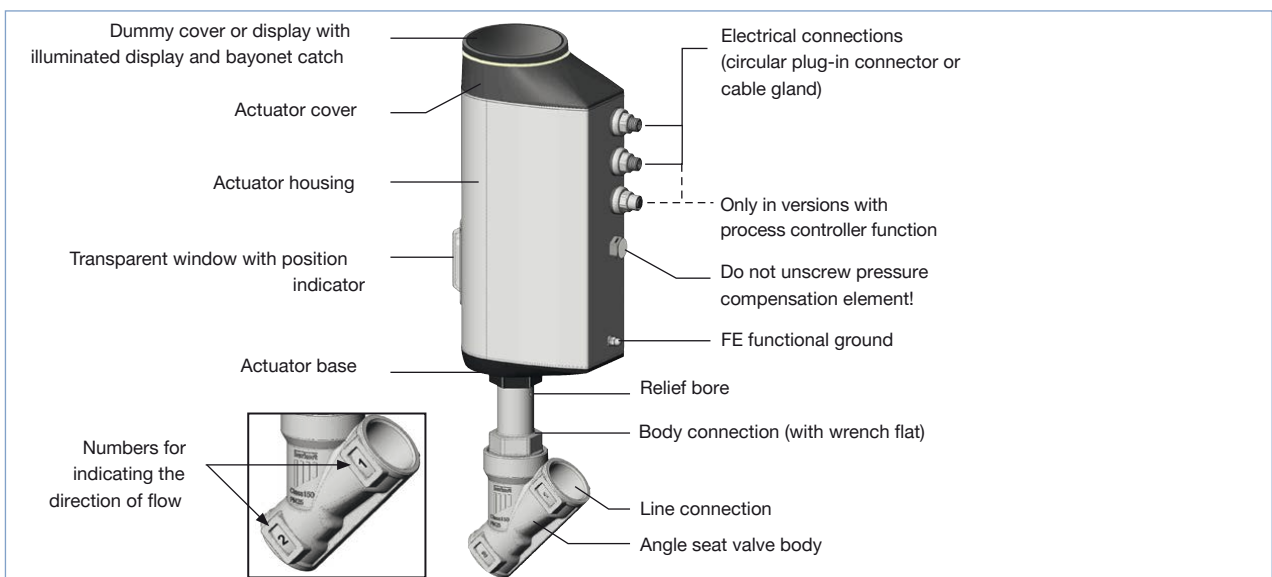

Structure, electromotive angle seat control valve Type 3360

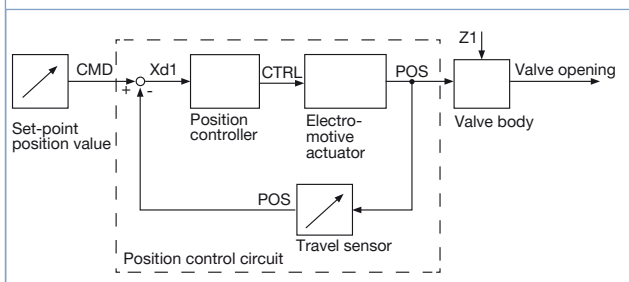

Integrated position controller

The position of the actuator (stroke) is regulated according to the set-point position value. The set-point position value is specified either by an external standard signal (analog) or via a field bus (digital). The travel sensor records the actual position (POS) of the electric linear actuator. The position controller compares this actual position value with the set-point position value (CMD) which is defined as standard signal. If there is a control difference (X_d^1), the electromotive actuator is controlled via the CTRL variable and the actual position value is changed accordingly.

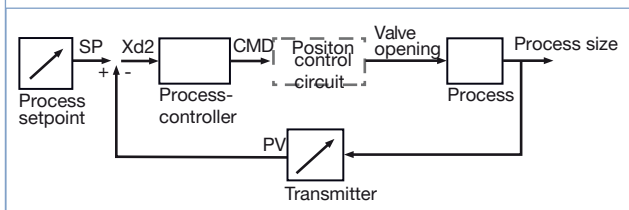

Integrated process controller

By implementing a PID controller can a process control be carried out. From the external signal (z.B. level, pressure, flow, temperature) the process setpoint and the actual process value is calculated on the control parameters (PID controller) for the target position of the valve.

Structure and function, continued

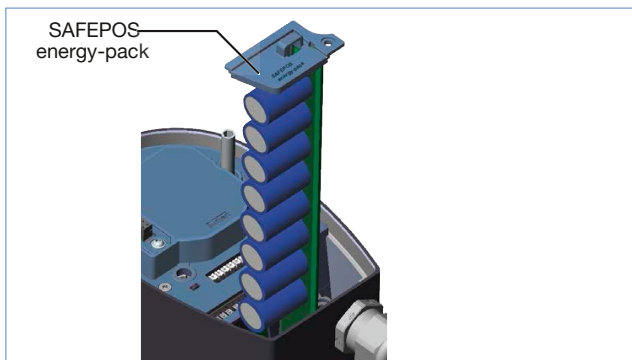

Safety position with energy storage (Option)

The safety starting positions in case of power interruption is realized with the optional energy storage SAFEOS energy-pack. The desired position is adjusted from the menu. Here any intermediate position can be defined in addition to the end positions (NO / NC). The energy storage has a lifespan of up to 10 years, depending on the operating conditions. The power of the energy storage is monitored and a warning is displayed to indicate its life is coming to an end. The memory is designed as a plug-in module making it easy to exchange. Without energy storage, the valve remains in the last position. The energy storage is fully charged after maximum 100 sec.ds (depending on the operating conditions) and ready to use.

Controls and indicators

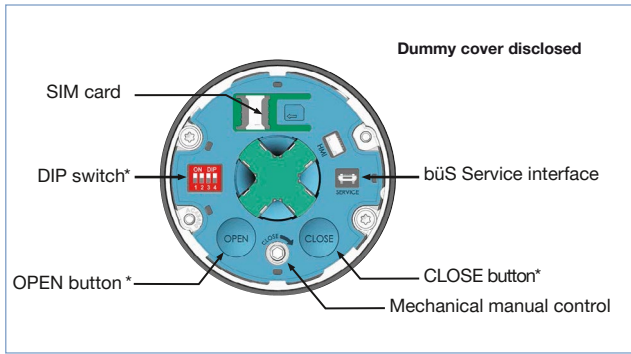

Devices without display module

In the version without control display the basic functions are operated by 4 DIP switches and 2 pushbuttons. These are located under the dummy cover which can be removed manual by turning. Through the bÜS service access, the device can also be configured in detail with the Bürkert communicator software. For this, the optional USB-bÜS interface kit is required.

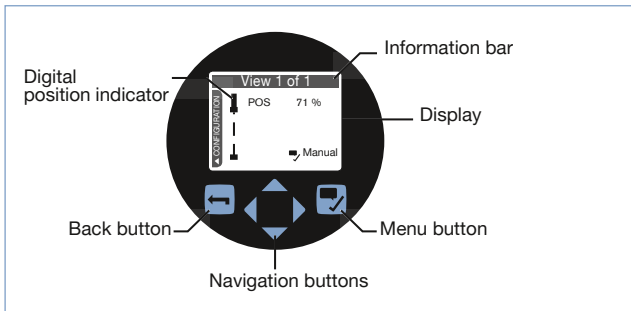

Robust display with control buttons (optional)

The robust display module is easy to use, it configures and displays all the required functions. In addition to the start screen you can also switch to the configuration view and user-specified views as needed. All functions of the device without display module like bÜS-Service interface are available, too.

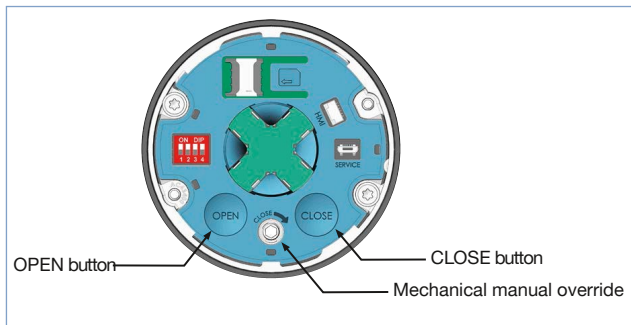

Manual and electrical operation

The manual override for mechanical operation of the valve is located under the dummy cover or the display module. Electrical manual override for the procedure is carried out directly on the touch screen, or in the version without a display by two buttons below the dummy cover.

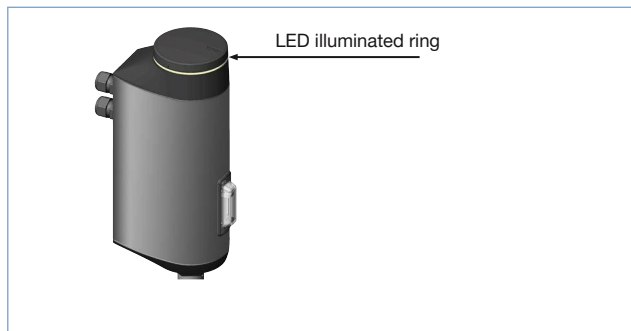

360° - LED Illuminated ring

To display the device status, the valve end position and the operating condition, a visible 360° LED illuminated ring is mounted around the dummy cover or the display module. The LED ring lights up, flashes or flashes in one or different colors. Depending on customer requirements 4 different LED modes can be selected (Namur mode, valve mode with warnings, valve mode without warnings, LED off)

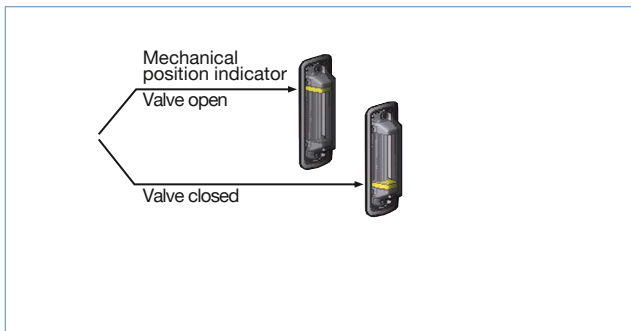

Mechanical position indicator

The mechanical position indicator also indicates when the supply voltage of the current valve position fails

Controls and indicators, continued

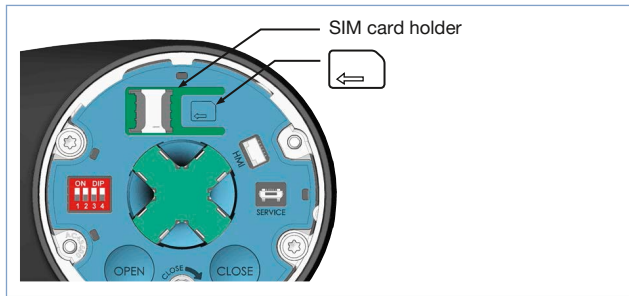

SIM card as data storage (option)

With the SIM card optional device-specific values and user settings can be saved and quickly transferred to another device.

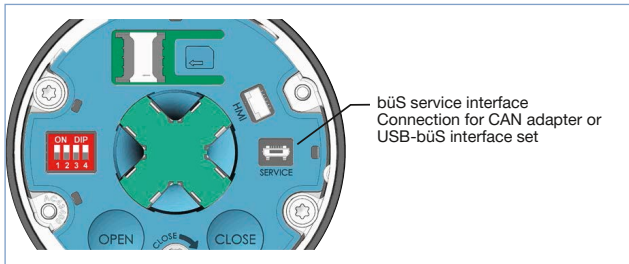

bÜS service interface

The bÜS service interface connects the device to the communicator software on a PC, laptop or smartphone. From there, a configuration of the device or failure diagnosis can be performed.

Design and materials view

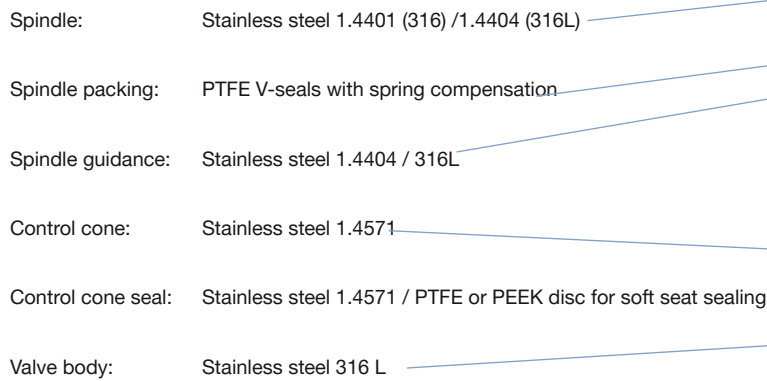
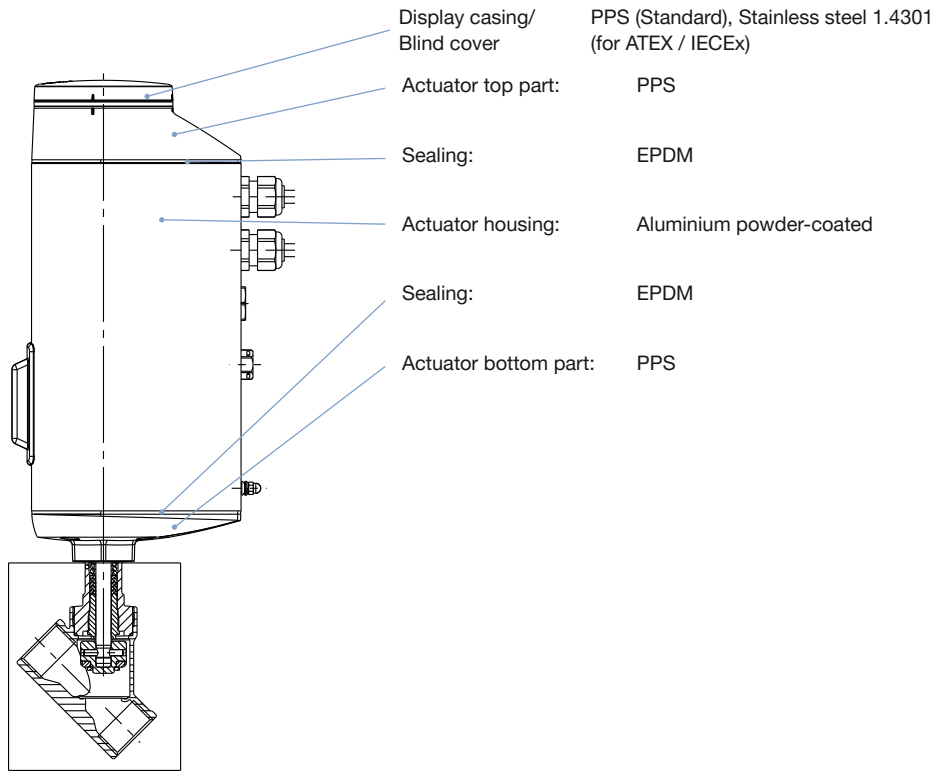

Note: The angle-seat control valve **Type 3360** could be delivered with miscellaneous port connection (thread, weld ends and clamp), there are not represented in the picture, but are made with same material as the valve body.

Technical data

Temperature chart

The maximum allowable ambient temperature and media temperature influence each other. The maximum allowable temperature curves of different device variants can be seen in the temperature chart. The curves were determined for maximum operating conditions (max. operating pressure and motor power). For deviating operating conditions an individual verification can be performed. Please contact your Bürkert office for more information.

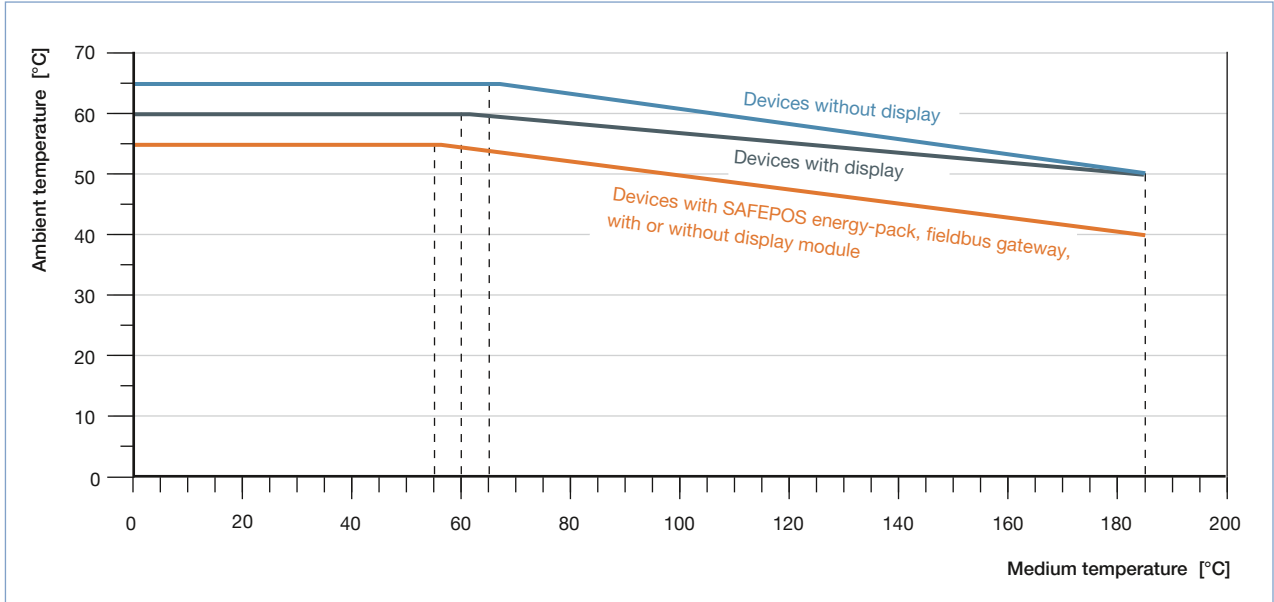

Flow characteristic

Modified equi-percentile flow characteristic, engineered for a quick response during peak flow demand and fine control at lower flow. Theoretical control ratio (KvS : Kv0): 50:1
KvR-value at 5% of stroke

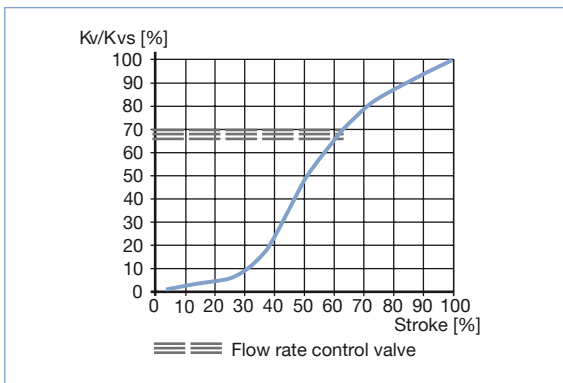

Selection chart for seat sealing

Seat sealing Type steel / steel is recommended for shut-off class III and IV.
Seat sealing with PTFE is used for shut-off class VI, if fluid temperature is < 130 °C. If the maximum fluid temperature exceeds 130 °C temporarily or permanently, then PEEK is used for seat sealing.

Shut-off class VI	PEEK / steel (T Media max. > 130 °C)	Operation pressure 0 ... 10 bar
	PTFE / steel	Operation pressure 0 ... 16 bar
Shut-off class III or IV	STEEL / steel	
	Fluid temperature -10 °C ... 130 °C	Fluid temperature 130 °C ... 185 °C

Port connection (tube)	Media pressure / seat sealing		Leakage class / seat sealing		K _v values with stroke [m ³ /h]						K _{vs} -value [m ³ /h]		
	[mm]	[inch]	Stainless steel o. PTFE Stainless steel [bar]	PEEK / Stainless steel [bar]	PTFE o. PEEK / Stainless steel	Stainless steel / Stainless steel	5%	10%	30%	50%		70%	90%
15	½	16*	-	-	VI	IV	0.16	0.17	0.4	2.7	4.0	4.8	5.0
20	¾	16	10	-	VI	IV	0.26	0.27	1.1	5.9	8.3	9.6	10.0
25	1	16	10	-	VI	IV	0.34	0.36	1.5	8.9	13.0	15.4	16.0
32	1.25	16	10	-	VI	IV	0.40	0.46	2.5	13.9	19.5	23.4	25.0
40	1.5	10	6	-	VI	III	0.48	0.66	5.1	20.0	28.3	34.5	36.0
50	2	6	-	-	VI	III	0.87	1.2	4.0	26.0	40.3	48.0	53.0

* Port connection 15 only available in stainless steel/stainless steel

Electrical control

Electrical data	
Protection class	3 acc. to DIN EN 61140
Electrical connections	Cable gland, 2 x M20 or 2 circular plug-in connector M12, 5 pin and 8 pin, 1 circular plug-in connector M12, 5 pin (only by process controller)
Operating voltage	24 V DC \pm 10 % max. residual ripple 10 %
Operating current [A]*	max. 3 A including actuator at max. load and charging current of the optional SAFEPOS energy-pack (charging current approx. 1 A)
Lifelong energy storage SAFEPOS energy-pack	up to 10 years (depending on operating conditions)
Electronic without actuator [W]*	min. 2 W, max. 5 W
Control	
Analogue input setpoint:	galvanically isolated from the supply voltage and analog output 0/4...20 mA (input resistance 60 Ω) 0...5/10 V (input resistance 22 k Ω)
Analogue actual value input 4...20 mA	Input resistance: 60 Ω Resolution: 12 bits
Frequency	Measurement range: 0...6500 Hz Input resistance: >30 k Ω Resolution: 1‰ of measurement value Input signal: >300 mVss Waveform: Sine wave, rectangle wave, triangle wave
Pt 100	Measurement range: -20 to +220 °C Resolution: <0.1 °C Measurement current: 1 mA
Output analogue:	Max. current 10 mA (for voltage output 0...5/10 V) Bürde (Last) 0...560 Ω (for current output 0/4...20 mA)
Output digital:	current limit 100 mA
Input digital:	0...5 V = log "0", 10...30 V = log "1" inverted input reversed accordingly
Communication interface:	Connection to PC via USB bÜS interface set
Communication Software:	Bürkert communicator

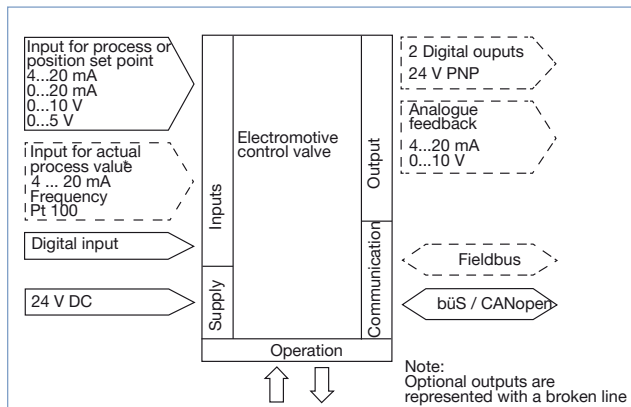
**Electrical control and interface**

The position of the actuator is regulated according to the set-point position value. The set-point position value is specified either by an external standard signal (analog) or via a field bus (digital).

Analogue Control

For analogue control 2 variants are available for the inputs and outputs and the connection interface

Input and output:

- * 1 analogue input, 1 binary input
- * 1 analogue input, 1 binary input, 1 analogue output, 2 binary output (option)
- 1 input for process actual value (for process controller version)

Interface:

- * cable gland with connection terminal
- * M12 circular connectors M12 (option)

Fieldbus: EtherNet/IP, PROFINET, Modbus TCP (option)

The Fieldbus Gateway for EtherNet / IP, PROFINET and Modbus TCP is integrated into a special module. It has 2 fieldbus connections with 4 pin M12 circular connectors. Under the gateway housing cover are the interfaces for the fieldbus connection and status LEDs. If there is a need to be include it in a network then the configuration of the Ethernet can be performed via the web server.



Dimensions [mm] - valve Type 3360 and valve system

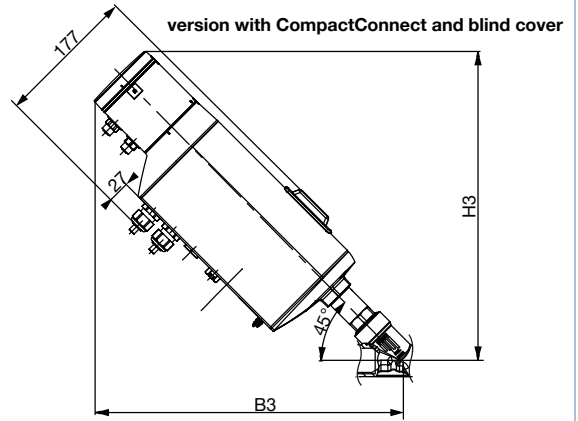
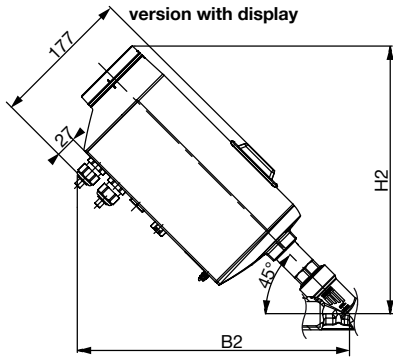
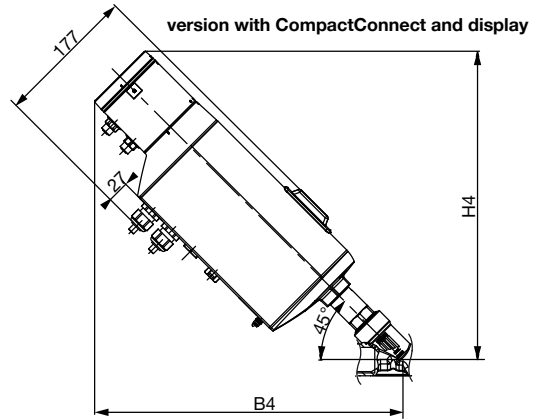
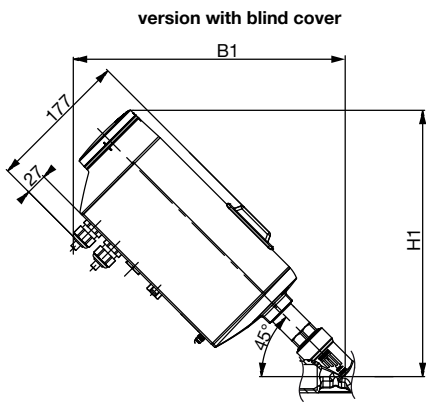

Port connection [mm]	Height [mm]				Width [mm]			
	H1	H2	H3	H4	B1	B2	B3	B4
15	306	308	359	359	314	314	359	359
20	314	316	367	367	321	321	367	367
25	333	336	387	387	341	341	387	387
32	347	349	400	400	354	354	400	400
40	349	351	402	402	356	356	402	402
50	362	364	416	416	370	370	416	416

Dimensions [mm] - body valve Type 3360

Threaded connection

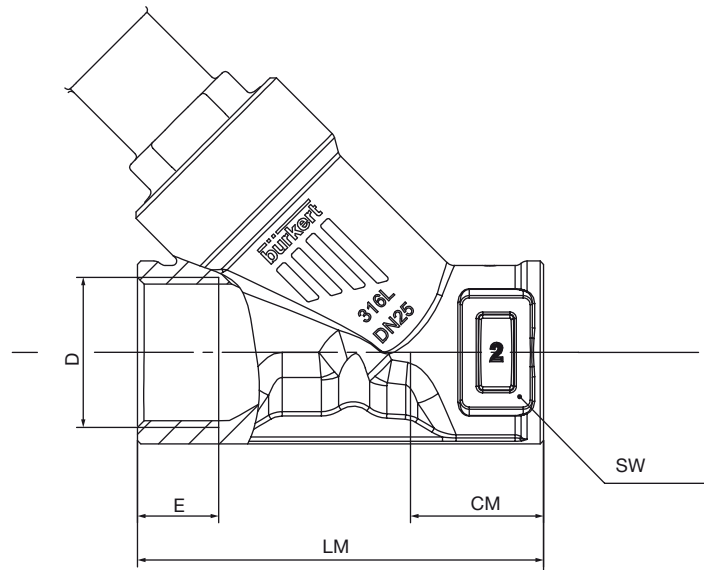

G, RC, NPT (EN ISO 228-1, ISO 7/1 /DIN EN 10226-2, ASME B 1.20.1)

Port size [mm]	CM [mm]	LM [mm]	SW [mm]	G		NPT		RC	
				D [mm]	E [mm]	D [mm]	E [mm]	D [mm]	E [mm]
15	24	65	27	G ½	14	NPT ½	13.7	RC ½	13.2
20	27	75	34	G ¾	16	NPT ¾	14.0	RC ¾	14.5
25	29.5	90	41	G 1	18	NPT 1	16.8	RC 1	16.8
32	36	110	50	G 1¼	16	NPT 1¼	17.3	RC 1¼	19.1
40	35	120	55	G 1½	18	NPT 1½	17.3	RC 1½	19.1
50	45	150	70	G 2	24	NPT 2	17.6	RC 2	23.4

Dimensions [mm] - body valve Type 3360

Weld ends port connection

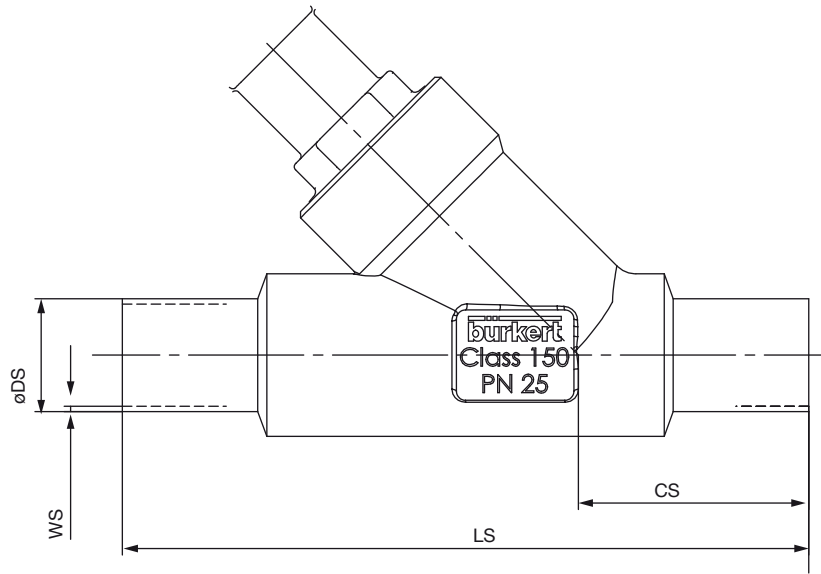





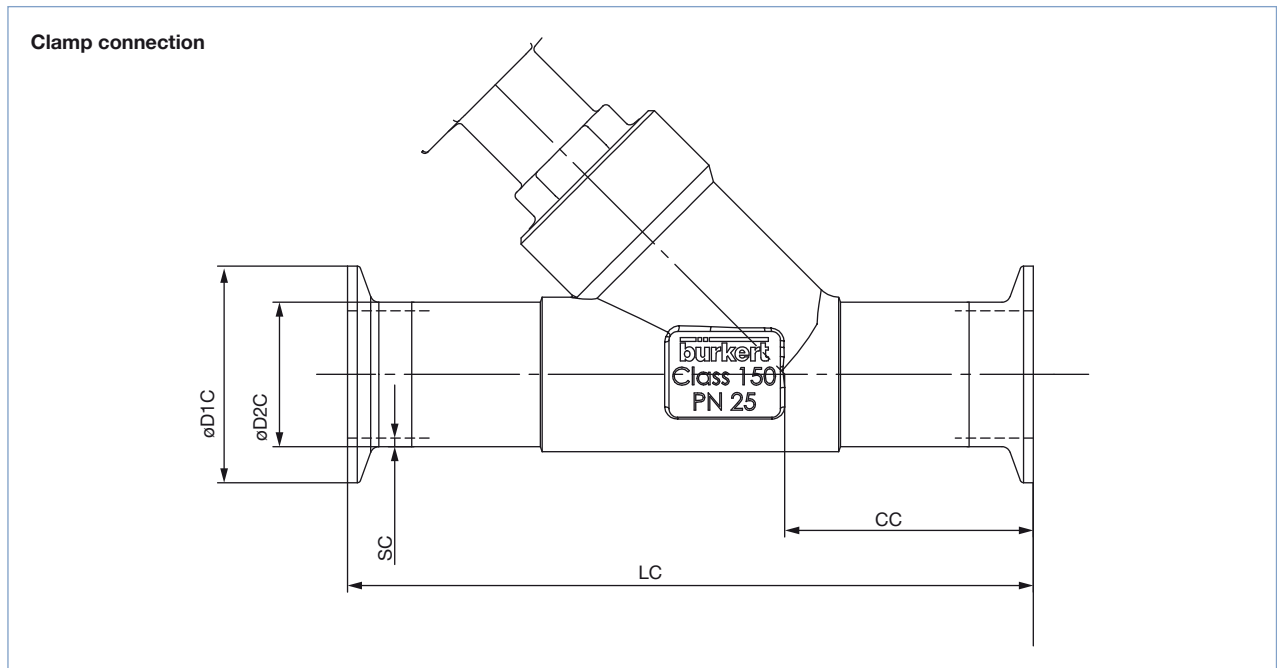







Port size [mm]	EN ISO 1127 Series 1 ISO 4200 DIN 11866 Series B				DIN 11850 R2 DIN 11866 Series A DIN EN 10357 Series A				ASME BPE DIN 11866 Series C			
	CS [mm]	LS [mm]	ØDS [mm]	WS [mm]	CS [mm]	LS [mm]	ØDS [mm]	WS [mm]	CS [mm]	LS [mm]	ØDS [mm]	WS [mm]
15	34	100	21.3	1.6	34	100	19	1.5	34	100	12.7	1.65
20	39	115	26.9	2.0	39	115	23	1.5	39	115	19.05	1.65
25	43	130	33.7	2.0	43	130	29	1.5	43	130	25.4	1.65
32	40	145	42.4	2.0	40	145	35	1.5	-	-	-	-
40	49	160	48.3	2.0	49	160	41	1.5	49	160	38.1	1.65
50	50	175	60.3	2.6	50	175	53	1.5	50	175	50.8	1.65

Dimensions [mm] - body valve Type 3360



Port size [mm]	Clamp: DIN 32676 Series B Tube: EN ISO 1127 Series 1 ISO 4200 DIN 11866 Series B					Clamp: ASME BPE DIN 32676 Series C Tube: ASME BPE DIN 11866 Series C					Clamp: BS 4825-3 Tube: BS 4825-1					Clamp: DIN 32676 Series A Tube: DIN 11850 Series 2 DIN 11866 Series A DIN EN 10357 Series A				
	LC	CC	ØDC1	ØDC2	SC	LC	CC	ØDC1	ØDC2	SC	LC	CC	ØDC1	ØDC2	SC	LC	CC	ØDC1	ØDC2	SC
15	156	49.0	50.5	21.3	1.6	130	49.0	25.0	12.7	1.65	130	49.0	25.0	12.7	1.20	130	49.5	19	34.0	1.5
20	150	56.5	50.5	26.9	1.6	150	56.5	25.0	19.05	1.65	150	56.5	25.0	19.05	1.20	150	57.0	23	34.0	1.5
25	160	58.0	50.5	33.7	2.0	160	58.0	50.5	25.4	1.65	160	58.0	50.5	25.4	1.65	160	58.5	29	50.5	1.5
32	200	57.5	50.5	42.4	2.0	-	-	-	-	-	-	-	-	-	-	180	58.0	35	50.5	1.5
40	200	69.0	64.0	48.3	2.0	200	69.0	50.5	38.1	1.65	200	69.0	50.5	38.1	1.65	200	69.5	41	50.5	1.5
50	230	77.5	77.5	60.3	2.6	230	77.5	64.0	50.8	1.65	230	77.5	64.0	50.8	1.65	230	78.0	53	64.0	1.5

Ordering chart for accessories

Accessory	Article no.
Connection cable:	
Connection cable with M12 socket, 4 pin, (length 5 m) for operating voltage	918038 
Connection cable with M12 socket, 8 pin, (length 2 m) for input and output signals	919061 
Connecting cable with M12 plug, 5 pin, (length 2 m) for input signals of process value (only for version with process controller)	559177 
USB-büS interface set:	
büS stick set 1 (including power supply unit, bus-stick, terminating resistor, Y-distributor, 0.7 m cable with M12 connector)	772426 
büS stick set 2 (including bus-stick, terminating resistor, Y-distributor, 0.7 m cable with M12 connector)	772551 
büS adapter for büS interface set (M12 on büS service interface Micro-USB)	773254 
büS cable extensions from M12 plug to M12 socket:	
Connecting cable, length 1 m	772404 
Connecting cable, length 3 m	772405 
Connecting cable, length 5 m	772406 
Connecting cable, length 10 m	772407 
Miscellaneous	
Bürkert Communicator	Infos at www.burkert.com
SIM card	291773 
Holding device for line connection DN15 to DN20	693770 
Holding device for line connection DN25 to DN50	693771 

Valve system – request for quotation

Note

You can fill out the fields directly in the PDF file before printing out the form.

▶ Please fill out and send to your nearest Bürkert office* with your inquiry or order

Company:	Contact person:
Customer no.:	Department:
Address:	Tel./Fax.:
Postcode/town:	E-Mail:

= mandatory fields to fill out

Quantity:

Required delivery date:

Operating data

Pipe line	DN <input type="text"/>	PN <input type="text"/>		
Pipe Material	<input type="text"/>			
<input type="checkbox"/> Process medium	<input type="text"/>			
<input type="checkbox"/> Type of medium	<input type="checkbox"/> Liquid	<input type="checkbox"/> Steam <input type="checkbox"/> Gas		
	min.	standard	max.	Unit
<input type="checkbox"/> Flow rate <small>(Q, Q_N, W)¹⁾</small>	<input type="text"/>	<input type="text"/>	<input type="text"/>	<input type="text"/>
<input type="checkbox"/> Temperature at valve inlet T1	<input type="text"/>	<input type="text"/>	<input type="text"/>	<input type="text"/>
<input type="checkbox"/> Absolute pressure at valve inlet P1	<input type="text"/>	<input type="text"/>	<input type="text"/>	<input type="text"/>
<input type="checkbox"/> Absolute pressure at valve outlet P2	<input type="text"/>	<input type="text"/>	<input type="text"/>	<input type="text"/>
Steam Pressure P _v	<input type="text"/>	<input type="text"/>	<input type="text"/>	<input type="text"/>
Kinematic viscosity (ν)	<input type="text"/>	mm ² /s or cSt		
Dynamic viscosity (η)	<input type="text"/>	mPa.s or cP		
Standard density	<input type="text"/>	Kg/m ³		
Max. sound level accepted	<input type="text"/>	dB (A)		

¹⁾ standard unit:
Liquid Q = m³/h;
Steam W = kg/h;
Gas Q_N = Nm³/h

Valves features

Cone seal material	<input type="checkbox"/> PTFE/Stainless steel	<input type="checkbox"/> Stainless steel/Stainless steel	<input type="checkbox"/> PEEK / Stainless steel
Nominal pressure	PN <input type="text"/>		
Seat size (orifice)	DN <input type="text"/>		
Type of connection	<input type="checkbox"/> Flanged	<input type="checkbox"/> Threaded	<input type="checkbox"/> Welded <input type="checkbox"/> Clamp
Control function	<input type="checkbox"/> with energy storage (delivey status NO)	<input type="checkbox"/> without energy storage (blocked in last position)	
	<input type="checkbox"/> with energy storage (delivey status NC)		

Valve system – request for quotation, continued

Control unit features

User display

- with touch display
 without touch display

Controller version

- Position controller
 Process controller

Communication

- | | |
|---|---|
| <input type="checkbox"/> Analogue | <input type="checkbox"/> Digital (fieldbus) |
| <input type="checkbox"/> 1 analogue IN / 1 binary IN | <input type="checkbox"/> Ethernet / IP |
| <input type="checkbox"/> 1 analogue IN / 1 binary IN
1 analogue OUT / 2 binary OUT | <input type="checkbox"/> Profinet |
| | <input type="checkbox"/> Modbus TCP |

Electrical connection

- Cable gland (without Bus) Multipol connection

SIM card

- with
 without

Approval and Conformity (optional)

- ATEX II Cat 3G/D / IECEx
 cULus Cert. No. 238179

Please specify item no. (if known):

Comments

To find your nearest Bürkert office, click on the orange box →

www.burkert.com

In case of special application conditions,
please consult for advice.

Subject to alteration.
© Christian Bürkert GmbH & Co. KG

1802/11_EU-en_00895299