



Control Modules

SEPS Series DC Power Supply Control Modules

- Relay or TRIAC output models accept inputs from remote sensors
- Convert 120 VAC or 240 VAC to 24 VDC power
- One or two SPDT relays or one or two opto-isolated TRIAC models are available



MULTI-MATE® Multi-Function Programmable Control Modules

- Program up to 25 functions
- Single or dual event models
- Dual outputs; TRIAC or NPN transistors
- Provides 24 VDC for remote sensor



PIC Series Product Inspection Control Modules

- Provides 24 VDC for remote sensor
- Used for on-line product sorting and inspection systems
- Programmable outputs and timing functions
- Requires interrogate and inspection sensors



SEPS Series Control Modules

DC Power Supply

SEPS Series plug-in modules offer a convenient means of converting 120 VAC or 240 VAC power into 24 VDC unregulated power for use with TRI-TRONICS DC powered sensors.

SEPS modules are available with the capability to convert NPN open collector transistor outputs from the sensor into conventional hard relay contact outputs or into solid state AC TRIAC outputs. All modules supply 24 VDC to remote sensors. Models are also available with either one or two relays, or one or two TRIACs.

All inputs of the SEPS relay devices can be addressed by the outputs of independent sensors. These inputs can also be paralleled to accept the output of a single sensor to drive loads in unrelated circuits. Feeding the complementary outputs of a remote sensor into the two separate inputs of the SEPS-5 dual output module emulates the action of a single-pole/double-throw solid state relay.

The number of sensors that can be simultaneously powered by a single **SEPS** power supply control module is dependent upon the total current draw of the sensor(s) to be used. Example: Up to three **SMARTEYE**[®] sensors or up to eight **MITY-EYE**[®] sensors can be powered by a single SEPS module. Refer to the Specifications of the specific sensor(s) to be used in order to calculate total current requirements.



SEPS-1 & SEPS-1-240 Power Supply

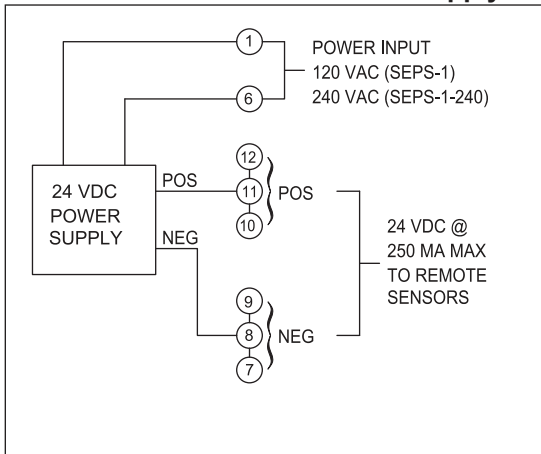

SEPS-2 & SEPS-2-240 Power Supply

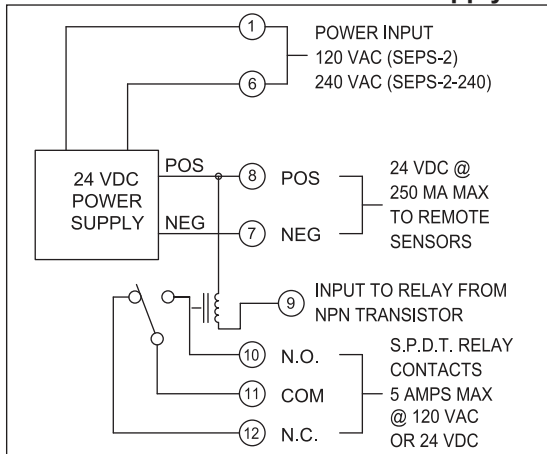

SEPS-3 & SEPS-3-240 Power Supply

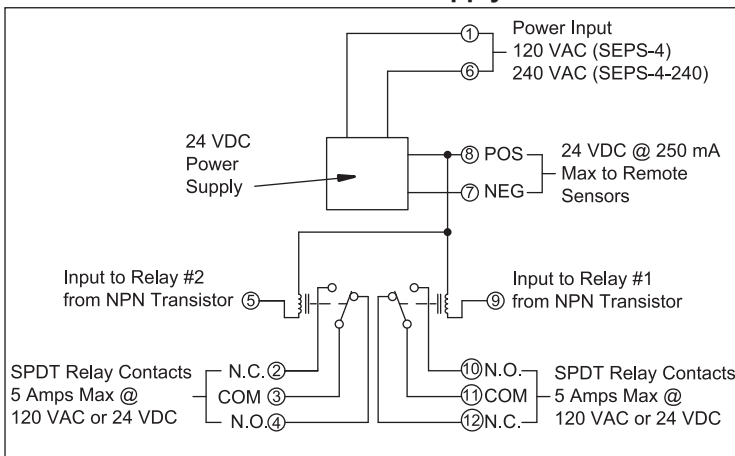

SEPS Series Control Modules

SEPS-4 & SEPS-4-240 Power Supply

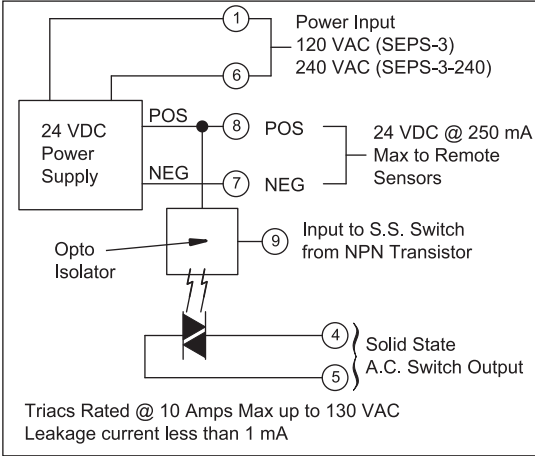

SEPS-5 & SEPS-5-240 Power Supply

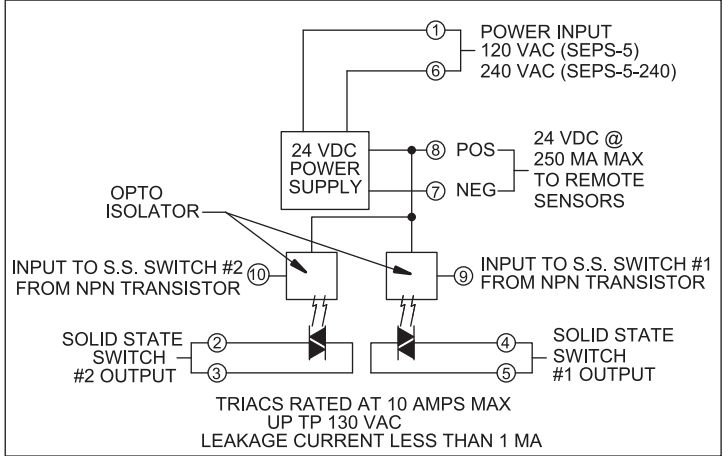

SEPS-6 & SEPS-6-240 Interface Module

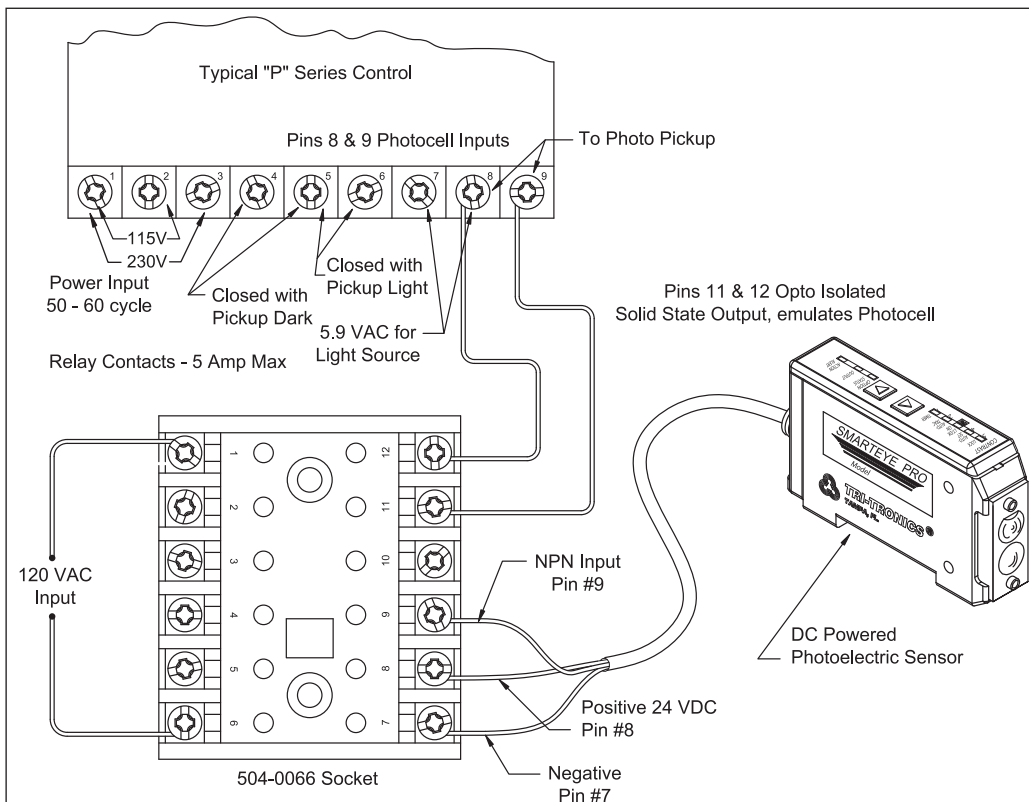

SEPS Series Control Modules

Model #	Operating Voltage		Description
SEPS-1	120 VAC	50/60 HZ	Power Supply Only
SEPS-1-240	240 VAC	50/60 HZ	
SEPS-2	120 VAC	50/60 HZ	PS with (1) 5 amp AC or DC SPDT Relay
SEPS-2-240	240 VAC	50/60 HZ	
SEPS-3	120 VAC	50/60 HZ	PS with (2) 5 amp AC or DC SPDT Relay
SEPS-3-240	240 VAC	50/60 HZ	
SEPS-4	120 VAC	50/60 HZ	PS with (1) 10 amp Solid State AC Triac
SEPS-4-240	240 VAC	50/60 HZ	
SEPS-5	120 VAC	50/60 HZ	PS with (2) 10 amp Solid State AC Triac
SEPS-5-240	240 VAC	50/60 HZ	
SEPS-6	120 VAC	50/60 HZ	Provides DC Power to replacement sensor and interfaces output to photocell input of older Tri-Tronics Controls, such as P-Type chassis.
SEPS-6-240	240 VAC	50/60 HZ	

NOTE: Power Output Current Draw; 24 VDC / 250 mA - Consider total number of sensors being used and amount of current being drawn.

Specify Socket Separately Model No. 504-0066

Dimensions

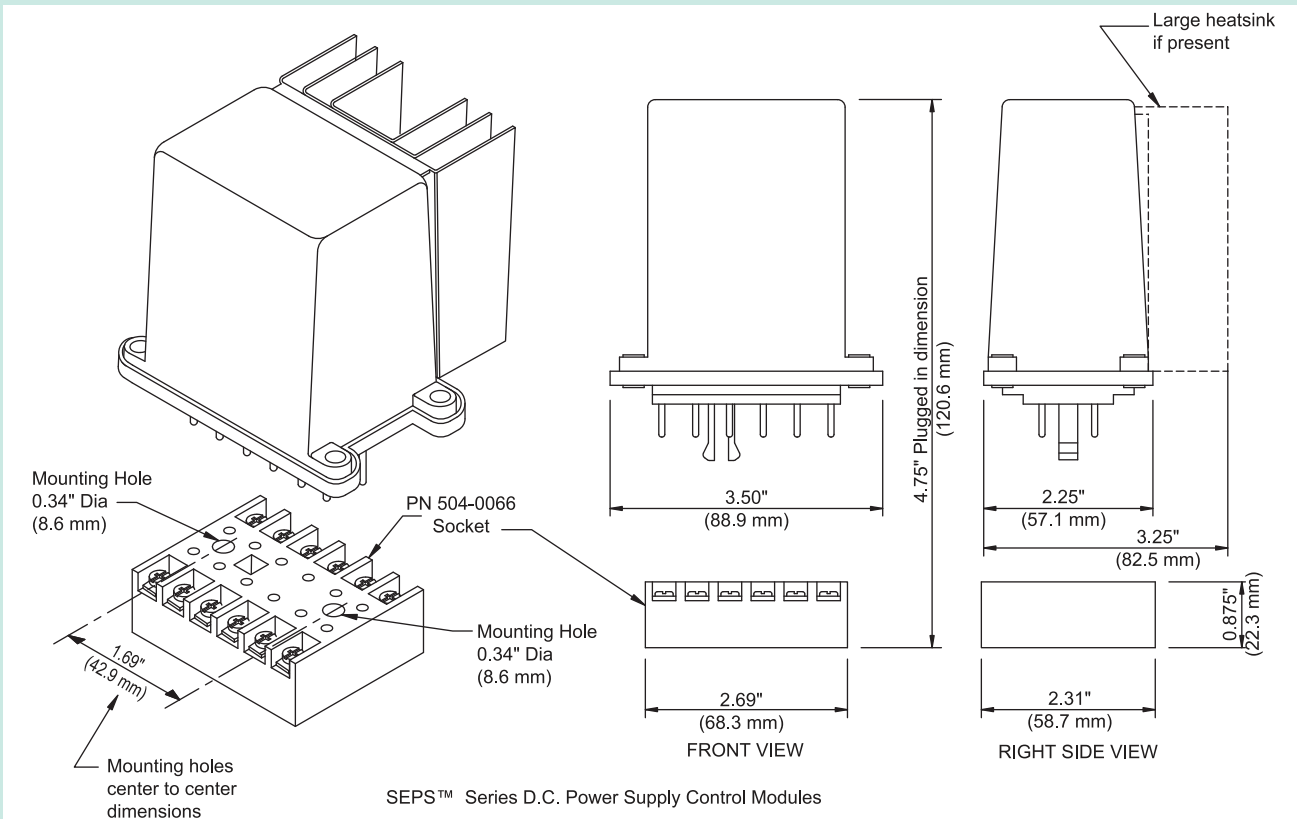

MULTI-MATE® Control Modules



MULTI-MATE®
Dual Function
Models

MULTI-MATE®
Dual Function
Models
with high current
output and heat sink

MULTI-MATE®
Single Function
Models

MULTI-MATE® Control Modules provide users with the flexibility to program up to 25 functions. These unique controls are the perfect match for use with TRI-TRONICS DC-powered sensors. They combine the simplicity of plug-in controls with the versatility of programming a wide variety of functions.

MULTI-MATE® Control Modules are available in either single or dual function models. All models provide a heavy-duty AC solid state output switch (TRIAC) as well as an output from a NPN open collector transistor. The controls also provide 24 VDC power for the remote sensor. The input to the control can be from an open

collector transistor or a switch.

Event functions, timing ranges, and operating sequence are easily programmed using 8-position mini dip switches, which are conveniently accessible through ports located on the front of the control. Switches 1 thru 5 program the function and 6 thru 8 set the timing range.

Many of the programmable timing/ control functions are useful in monitoring product flow, i.e. "ON" delay, "OFF" delay, retriggerable oneshot/ motion, etc. Additional programmable functions are useful to control and manipulate products through the manufacturing process, such as "LATCH," one shot, etc.

Features

- The simplicity of a plug-in module with the versatility of programming up to 25 functions.
- Available in both Single Event (Model PM-8100/8125) and Dual Event (Model PM-8200/8225) versions, both providing dual outputs.
- Gives you the unique capability of programming for one function now, then changing the program as your needs change.

Some examples of applications where the timing and control functions provided by the MULTIMATE® are extremely useful are:

Applications:

- Jam detection
- Product void detection
- Motion detection
- Registration control
- Door control
- Over travel/limit/stop control
- Edge guide control
- Splice detection
- Product ejection monitor
- Batch counting
- Hopper level control
- Loop level control

Typical Applications



1. Accumulation detection

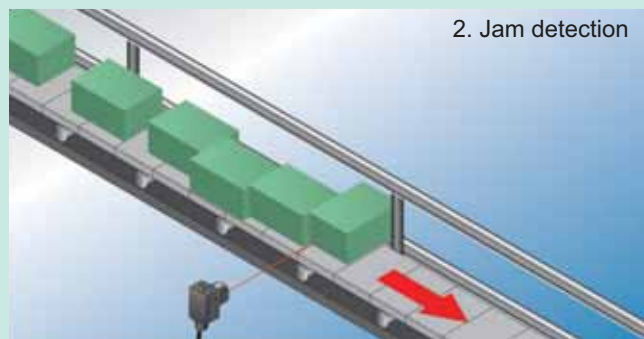

2. Jam detection

MULTI-MATE® Control Modules

Single and Dual Event controls offer:

Dual Outputs:

Dual Outputs:

1. TRIAC (AC switch) — selection of medium-duty rated at 1/6 HP or heavy-duty rated up to 1/4 HP.
2. NPN grounded emitter open collector output transistor rated to 100 mA maximum.

NOTE: 24 VDC power supply provides power to all DC sensors.

A variety of programmable functions:

Single Event Model PM-8100/8125:

- Motion (Retriggerable One-Shot)
- On-Delay
- Off-Delay
- One-Shot
- Latch

Dual Event Model PM-8200/8225:

25 programmable functions. These are the most common:

- On-Delay then Off-Delay
- One-Delay then One-Shot
- On-Delay then Latch
- Off-Delay then One-Shot
- Off-Delay then Latch
- One-Shot Input and One-Shot
- One-Shot (Delay) then One-Shot
- One-Shot (Delay) then Latch
- Motion then One-Shot
- Motion then Latch
- Latching Input then On-Delay
- Latching Input then One-Shot



Event functions are programmed by an 8-position mini-dip switch, easily accessible through a port at the front of the control. Switches 1-5 program the function; switches 6-8 set the maximum time limits as follows:

Switch #1 - Motion (Retriggerable One-Shot)

Switch #2 - Delay

Switch #3 - Latch

Switch #4 - Light/Dark

Switch #5 - Output Invert (N/A on first function of Dual Event Model PM-8200)

Switch #6* - 1 second (Max. timing switch)

Switch #7* - 5 seconds (Max. timing switch)

Switch #8* - 15 seconds (Max. timing switch)

*With Switches #6, #7 and #8 "OFF," maximum time would be 1/2 second if the adjustments on top of the controls are turned to maximum. If Switches, #6, #7 and #8 are in the "ON" position, the maximum time would be 21 seconds. Timers are additive.

NOTE: Time adjustments are not applicable in "Latching" functions.

MULTI-MATE® Control Modules

Programming

In the programming instructions below, it is assumed that:

1. Input from the sensor is normally "OFF" and the function is to occur on the leading edge of the input event. If this is not the case, simply reverse the position of Switch #4 (Light/Dark).
2. Output (TRIAC) is normally "OFF". If this is not the case, simply reverse the position of Switch #5 (Output Invert).



Single Event (Model PM-8100 and PM-8125)

SEQUENCE*	PLACE LISTED SWITCHES TO >ON (ALL OTHERS OFF <)	CONTROL SEQUENCE*
"On" Delay	2,4	1
"Off" Delay	2,5	2
One-Shot	5	3
Motion Retriggerable One-Shot	1,5	4
Latch, Edge-Triggered	3,5	5

4

Plug-In Control Modules



Dual Event (Model PM-8200 and PM-8225)

PLACE LISTED SWITCHES TO > ON (ALL OTHERS OFF <)	INPUT EVENT	OUTPUT EVENT	CONTROL SEQUENCE*
"On" Delay then "Off" Delay	2,4	2,5	6
"On" Delay then One-Shot	2,4	5	7
"On" Delay then Latch	2,4	3,5	8
"Off" Delay then One-Shot	2	5	9
"Off" Delay then Latch	2	3,5	10
One-Shot Triggers One-Shot	All "OFF"	4,5	11
One-Shot (Delay) than One-Shot	All "OFF"	5	12
One-Shot (Delay) then Latch	All "OFF"	3,5	13
Motion then One-Shot	1	5	14
Motion then Latch	1	3,5	15
Latch then "On" Delay	3	2	16
Latch then One-Shot	3	4,5	17

MULTI-MATE® Control Modules

Functional Control and Timing Sequence Data

1

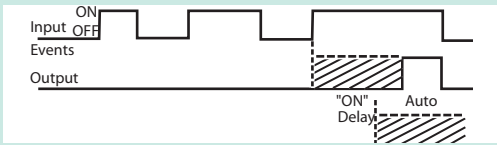

"ON" Delay

2

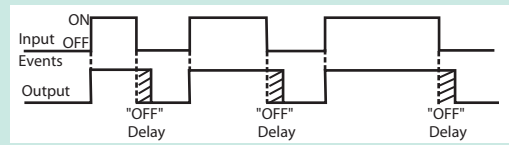

"OFF" Delay Pulse Stretcher

3

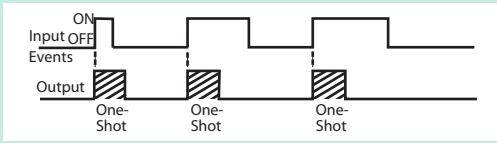

One-Shot

4

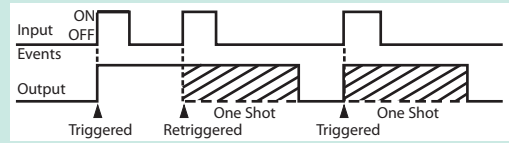

Motion Detection, Retriggerable One-Shot

5

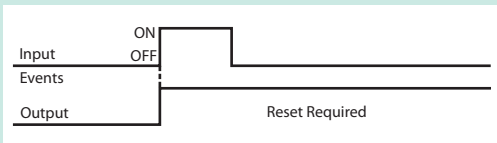

Latching, Edge Triggered

6

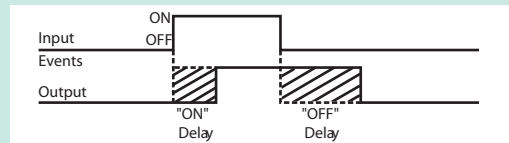

"ON" Delay then "OFF" Delay

7

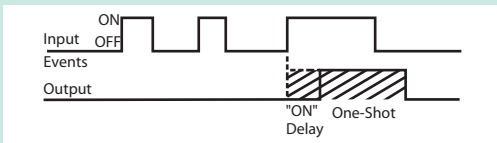

"ON" Delay, then One-Shot

8

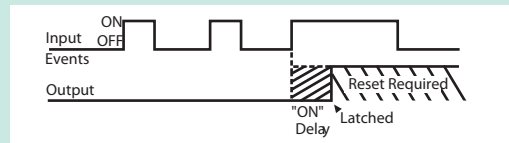

"ON" Delay then Latch

9

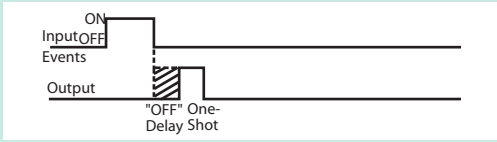

"OFF" Delay then One-Shot

10

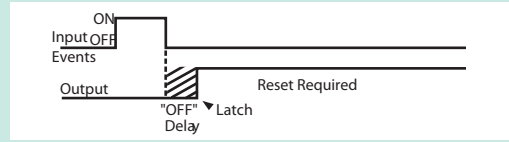

"OFF" Delay then Latch

11

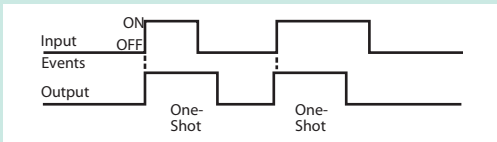

One-Shot Triggers One-Shot

12

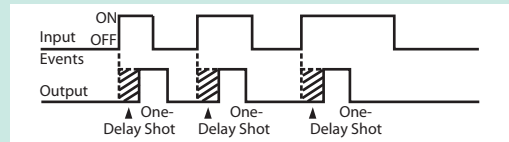

One-Shot Delay, then One-Shot

13

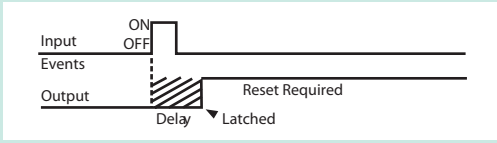

One-Shot Delay, then Latch

14

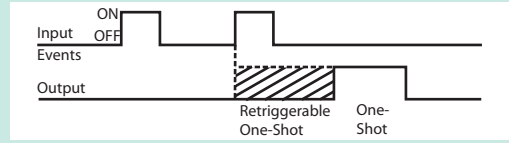

Stop Motion, then One-Shot

15

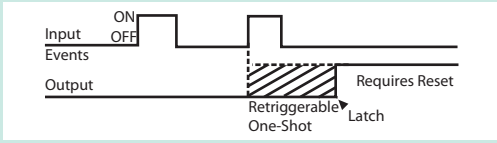

Stop Motion, then Latch

16

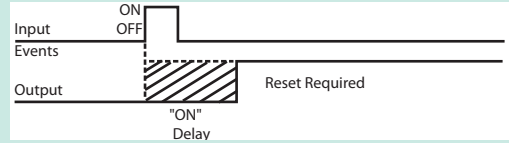

Latch then "ON" Delay

17

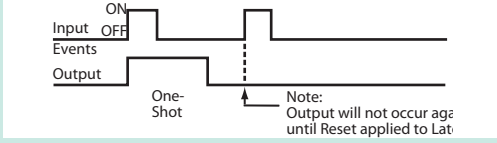

Latch, then One-Shot

MULTI-MATE® Control Modules

Electrical Specifications

Input Power Requirements: Choice of 120 or 240 VAC \pm 10%; 50-60 Hz models.

DC Power Output: 24 VDC Nominal @ 150mA . (Unregulated) (Supplies power to DC sensor)

Output Relay: Models PM-8100/PM-8200 – Solid state AC relay. Triac rated at up to 1/6 HP motor load or 3.2 amp inductive load at 115 VAC.

Models PM-8125/PM-8225 – Equipped with larger heat sink Triac rated up to 1/4 HP motor load or 5.4 amp inductive load at 115 VAC.

Output Transistor (Pin 12): NPN grounded emitter open collector output transistor rated at 100mA maximum. Maximum voltage = 40 VDC.

Input (Pin 7): Opto-isolated for high noise immunity. Accepts input from NPN open collector transistor or switch to ground. Responds to input durations as short as 100 microseconds.

Reset/Inhibit (Pin 10 or 11): Accepts input from NPN open collector transistor or switch to ground (Pin 9). Activated when Pin 9 is shorted to Pin 10 or 11.

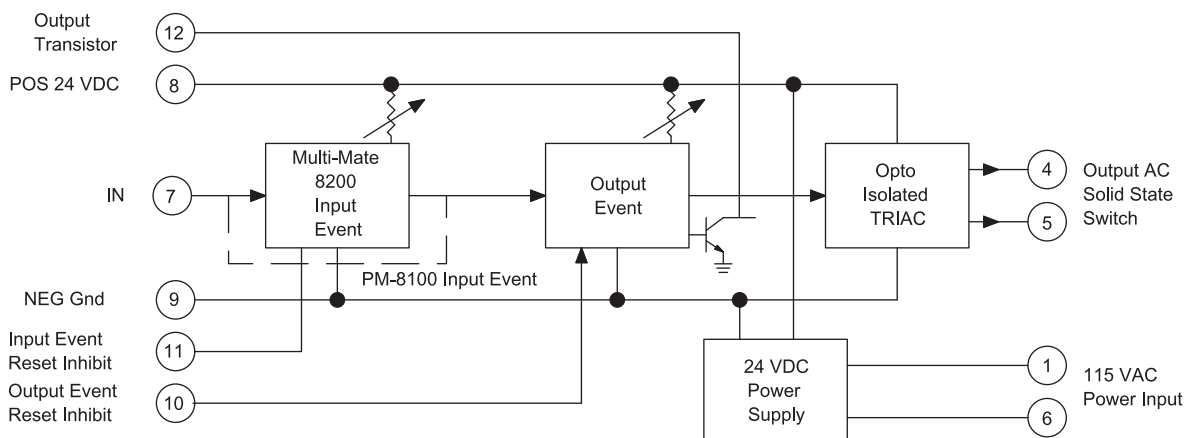
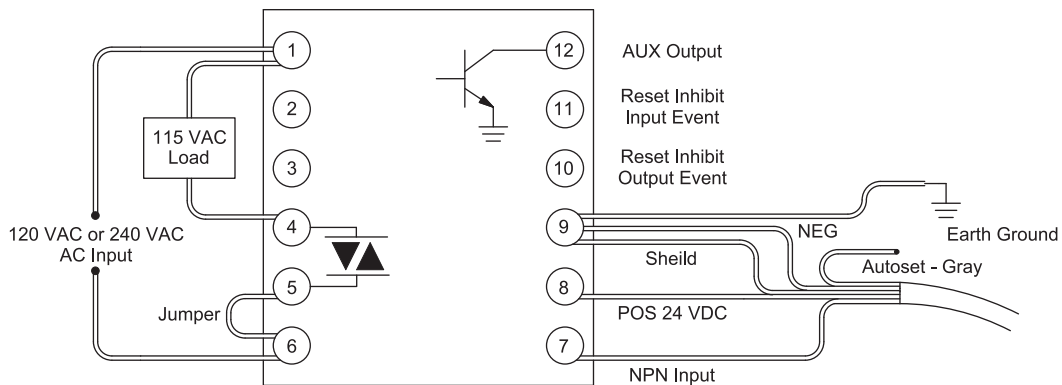

MULTI-MATE® Control Modules

Model	Current	Power Output	Operating Draw Voltage	Description
PM-8100	24 VDC 150mA	120 VAC	50/60 HZ	Single Function Programmable with Solid State AC Switch, 1/6 HP rated
PM-8100-240	24 VDC 150mA	240 VAC	50/60 HZ	Single Function Programmable with Solid State AC Switch, 1/6 HP rated
PM-8125	24 VDC 150mA	120 VAC	50/60 HZ	Single Function Programmable with Solid State AC Switch, 1/4 HP rated
PM-8125-240	24 VDC 150mA	240 VAC	50/60 HZ	Single Function Programmable with Solid State AC Switch, 1/4 HP rated
PM-8200	24 VDC 150mA	120 VAC	50/60 HZ	Dual Function Programmable with Solid State AC Switch, 1/6 HP rated
PM-8200-240	24 VDC 150mA	240 VAC	50/60 HZ	Dual Function Programmable with Solid State AC Switch, 1/6 HP rated
PM-8225	24 VDC 150mA	120 VAC	50/60 HZ	Dual Function Programmable with Solid State AC Switch, 1/4 HP rated
PM-8225-240	24 VDC 150mA	240 VAC	50/60 HZ	Dual Function Programmable with Solid State AC Switch, 1/4 HP rated
504-0066				Plug-In Socket Sold Separately

NOTE: 1/6 HP Rating = 3.2 amp inductive load at 115 VAC, 1/4 HP Rating = 5.4 amp inductive load at 115 VAC

Dimensions

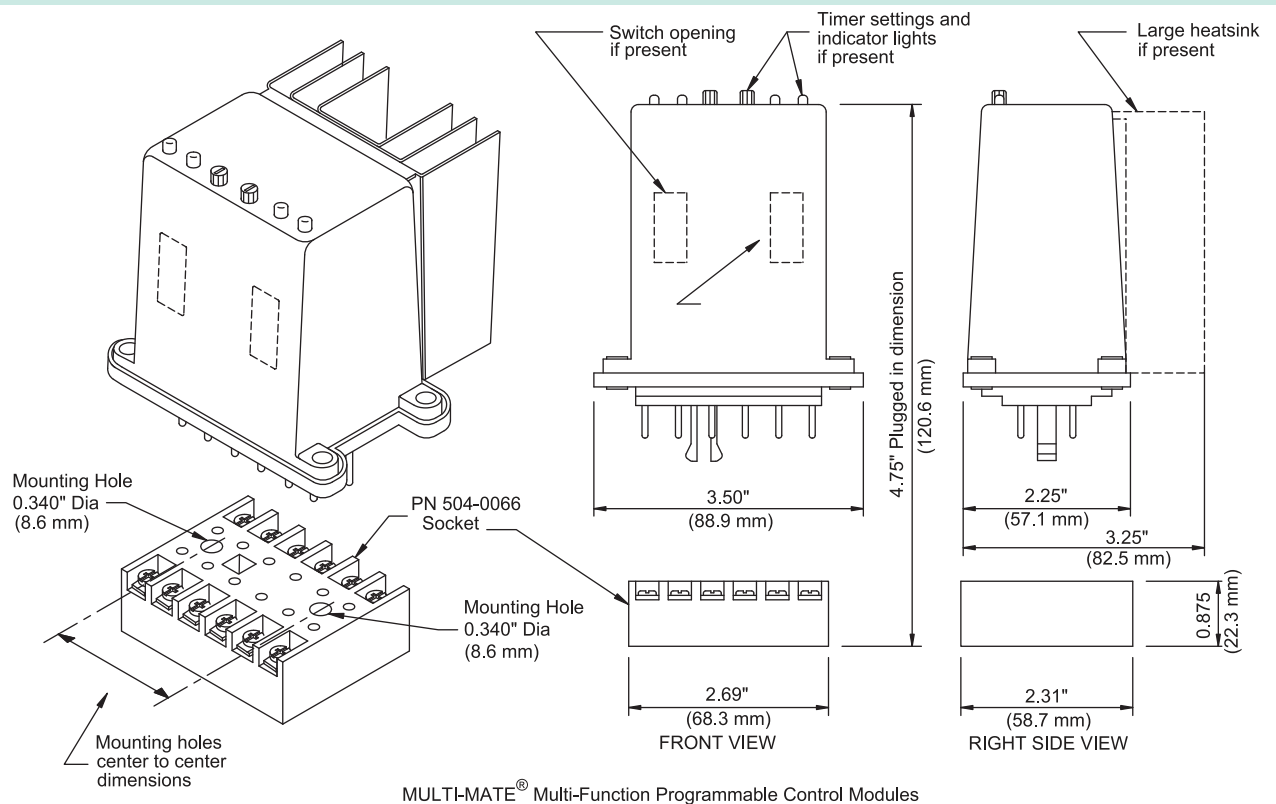

Control Modules

Product Inspection Control

The PIC Series Programmable Controls were designed to meet the demand for an easy-to-install and easy-to-use control for product sortation and inspection systems.

PIC Controls are used with a minimum of two DC powered sensors. Any “product sensor” is used to detect the arrival of the product, and the “inspection sensor” (a **SMARTEYE**® or **EZ-PRO**®) is used to identify or inspect the product for the critical identifying features; e.g., variations in color, pattern, position, orientation, size, opacity, or surface reflectivity.

PIC controls supply 24 VDC power to both the product and inspection sensors. The control accepts inputs from NPN open collector transistor outputs of the remote sensors. Each input is opto-isolated to prevent problems with electrical noise and interference. The status of each input can be easily monitored via LED indicators located on the top of the control.

Programming

PIC Controls can be programmed to provide one of two outputs—either an adjustable one-shot (momentary) output or a latching output – whenever it responds to the recognition of the identifying feature. An optional program allows for an output response whenever the identifying feature has not been identified or detected.

An adjustable delay can be programmed to provide time for the product to move out of view of the sensors to a position where an electro-mechanical device can be located to eject the product from the conveyor line.

The optional latching output can be used to shut the machine off until a manual reset command from a remote switch is applied to the reset input of the control.

The output of the PIC Control is from a heavy-duty solid state TRIAC Switch that is capable of directly driving AC loads.

An additional open collector NPN transistor output provides the capability to drive logic controls such as counters or PLCs. This output is ideal when the application requires counting either “bad” or “good” products.

Operational Examples

The “product sensor” detects the arrival of the object or product to be inspected for the purpose of telling the control when to perform the inspection task. This sensor (also referred to as the “leading edge” sensor) generates an instantaneous “interrogate” or “look now” signal. It can be easily converted to a “trailing edge” sensor by simply switching to the sensor’s complementary output, making it the interrogate input; e.g., switch from white to green wire or vice versa.



The “inspection sensor” performs the actual inspection task, such as detecting the presence or absence of a top or lid of a container, the correct color of a lid, the presence or absence of a label, foil liner or handle, etc. The list of inspection tasks this system will perform is virtually endless.

Utilizing a TRI-TRONICS® high-performance sensor with the PIC Control makes this a unique system that is capable of responding to color, opacity, reflectivity, pattern, position, size or orientation.

In some applications, more than one “inspection sensor” can be used in the control system by combining multiple outputs into one common input for “and/or” gating functions. Examples of where this capability is useful are in the detection of labels on both sides of a bottle or for inspection of a complex pattern.

For inspecting the bottle labels, one PIC Control is used with one “product sensor” and two “inspection sensors”.

For pattern recognition, one, two, or more **SMARTEYE**® sensors are used to view light/dark areas on complex patterns for specific identification purposes.

Contact your local Representative or the Factory for applications assistance.

Typical Applications

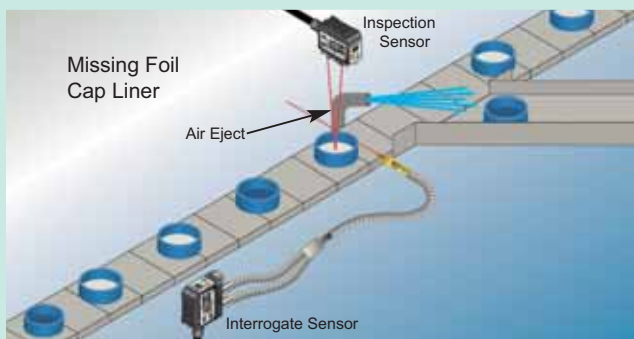

Control Modules

PIC-1 PRODUCT INSPECTION CONTROL

MISSING LINER DETECTOR, COLOR INSPECTION, CAP INSPECTION

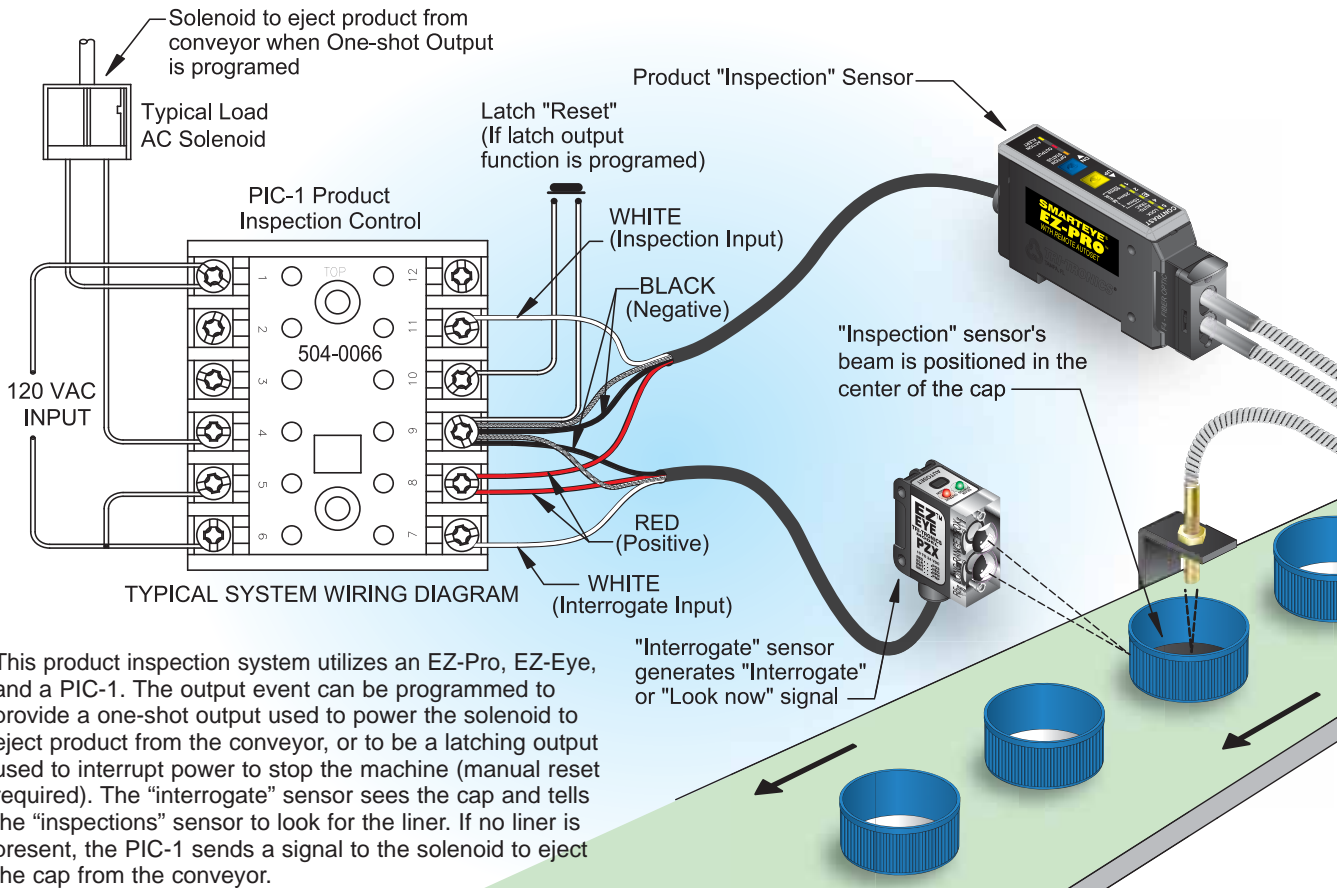

Operational Block Diagram

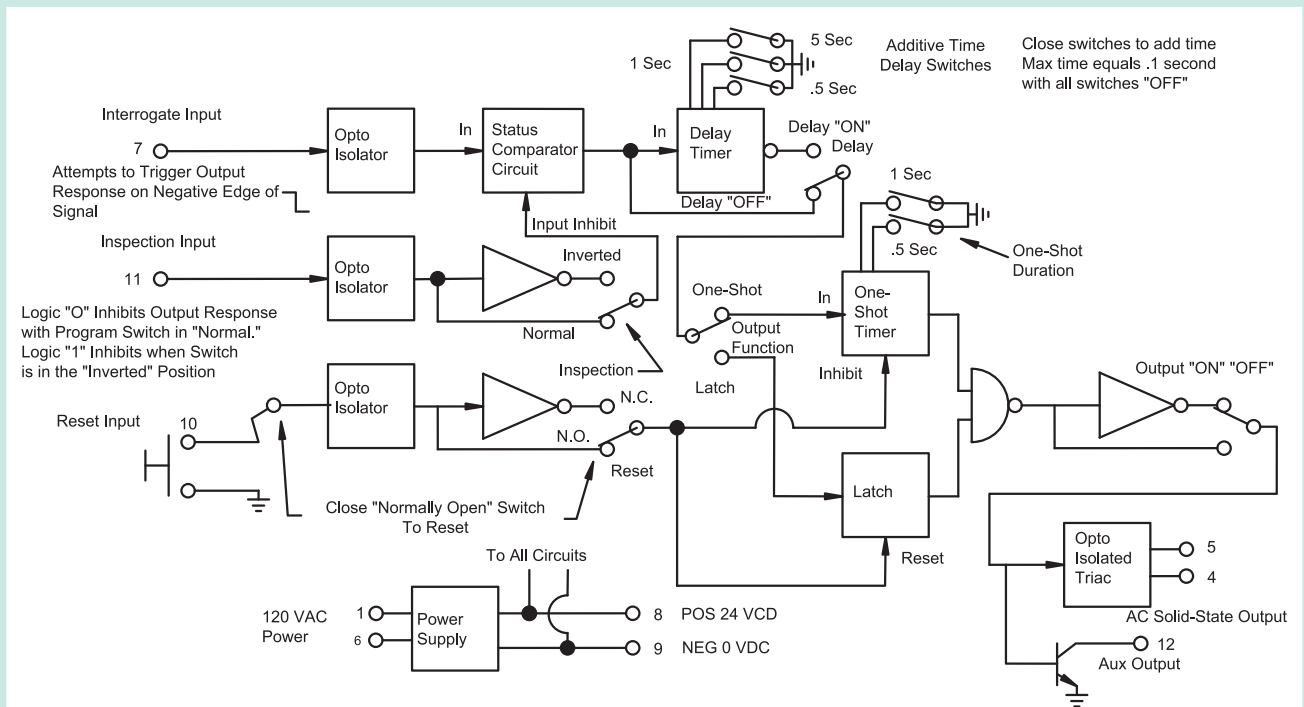

Control Modules *Product Inspection Control*

Input Power requirements (Pins 1 and 6)

Model PIC-1: 120 VAC + 10%; 50-60 Hz Model
PIC-1-240: 240 VAC + 10%; 50-60 Hz

D.C. Power Output (POS Pin 8, NEG Pin 9) - All Models

24 VDC nominal @ 150mA (unregulated)

Output Relay

(pins 4 and 5)
Solid state AC relay drives up to 1/6 HP load or 3.2 amp inductive load at 115 VAC MOV protection provided.

Output Transistor (Pin 12) - All Models

NPN grounded emitter open collector output transistor rated at 100mA maximum.

Maximum voltage =

40 VDC. Zener protected from voltage spikes.

Inputs

(Pins 7,10 and 11) - All Models

All inputs are opto-isolated for high immunity to noise. All accept inputs from NPN transistors or switch to negative. Inputs respond to input durations

as short as 100 μ s.
Interrogate Input: Pin 7.
Inspection Input: Pin 11.
Reset Input (for latched output): Pin10.

Model	Power Output Current	Operating Voltage	Description
PIC-1	24 VDC 150mA	120 VAC 50/60 HZ	Solid State AC Relay, 10 Amp Triac
PIC-1-240	24 VDC	240 VAC 50/60 HZ	Solid State AC Relay, 10 Amp Triac
PIC-1AB	24 VDC 150mA	120 VAC 50/60 HZ	Solid State DC Relay, 10 Amp Triac
504-0066			Plug-In socket sold separately

4

Plug-In Control Modules

Dimensions

